

**Department of Computer  
Science and Engineering**

***Curriculum Structure  
(Autonomy)***

***1<sup>st</sup> to 8<sup>th</sup> Semester***

## Curriculum for BTech in Computer Science and Engineering

### Under Autonomy, Total Credit-198

<b>1<sup>st</sup> Semester</b>							
<b>Sl No</b>	<b>Paper Code</b>	<b>Theory</b>	<b>Contact Hours /Week</b>				<b>Credit Points</b>
			<b>L</b>	<b>T</b>	<b>P</b>	<b>Total</b>	
1	M 101	Mathematics -I	3	1	0	4	4
2	CH 101/ PH 101	Chemistry (Gr. A) / Physics - I(Gr. B)	3	1	0	4	4
3	EE 101/ EC 101	Basic Electrical Engineering (Gr. A) / Basic Electronics Engineering (Gr. B)	3	1	0	4	4
4	HU 101	Communicative English	2	0	0	2	2
5	ME 101	Engineering Mechanics	3	1	0	4	4
Total of Theory						18	18
<b>A. PRACTICAL</b>							
6	HU191	Lang. Lab. and Seminar Presentation	0	0	2	2	1
7	CH 191/ PH191	Chemistry Lab (Gr. A) / Physics -I Lab(Gr. B)	0	0	3	3	2
8	EE 191/ EC 191	Basic Electrical Engineering Lab (Gr. A) /Basic Electronics Engineering Lab(Gr. B)	0	0	3	3	2
9	ME 191/ ME 192	Engg Drawing & Graphics(Gr A)/ Workshop Practice (Gr-B)	0	0	3	3	2
<b>B. SESSIONAL</b>							
10	XC181	Extra Curricular Activity (NSS/ NCC)	0	0	2	2	1
Total of Practical & Sessional						13	08

2 <sup>nd</sup> Semester							
SI No	Paper Code	Theory	Contact Hours /Week				Credit Points
			L	T	P	Total	
1	M 201	Mathematics -II	3	1	0	4	4
2	CH 201/ PH 201	Chemistry (Gr. B) / Physics - I(Gr. A)	3	1	0	4	4
3	EE 201/ EC 201	Basic Electrical Engineering (Gr. B) / Basic Electronics Engineering (Gr. A)	3	1	0	4	4
4	CS 201	Computer Fundamentals & Principle of Computer Programming	3	1	0	4	4
5	ME 201	Engineering Thermodynamics & Fluid Mechanics	3	1	0	4	4
Total of Theory						20	20
<b>B. PRACTICAL</b>							
6	CS291	Computer Fundamentals & Principle of Computer Programming Lab	0	0	3	3	2
7	CH 291/ PH291	Chemistry Lab (Gr. B) / Physics -I Lab(Gr. A)	0	0	3	3	2
8	EE 291/ EC 291	Basic Electrical Engineering Lab (Gr. B) /Basic Electronics Engineering Lab(Gr. A)	0	0	3	3	2
9	ME 291/ ME 292	Engg Drawing & Graphics(Gr B)/ Workshop Practice (Gr-A)	0	0	3	3	2
Total of Practical						12	08
<b>C. SESSIONAL</b>							
10	MC 281	Soft Skill Development	0	0	2	2	0

3 <sup>rd</sup> Semester								
SL No	Type	Code	A. THEORY	Contact hours				Cr. Points
				L	T	P	Total	
1	BS	M(CSE)301	Mathematics-III	3	1	0	4	4
2	BS	PH301	Physics-II	3	0	0	3	3
3	ES	EE(CSE)301	Circuit Theory and Network	3	0	0	3	3
4	PC	CS301	Data Structures	3	0	0	3	3
5	PC	CS302	Digital Electronics and Computer Organization	3	0	0	3	3
			<b>Total Theory</b>				16	16
			<b>B. PRACTICAL</b>					
6	BS	PH391	Physics-II Lab	0	0	3	3	2
7	ES	EE(CSE)391	Circuit Theory and Network Lab	0	0	3	3	2
8	PC	CS391	Data Structures Lab	0	0	3	3	2
9	PC	CS392	Digital Electronics and Computer Organization Lab	0	0	3	3	2
			<b>Total Practical</b>				12	8
<b>C. SESSIONAL</b>								
10	HU	HU381	Technical Report writing and Language Practice Lab	0	0	2	2	1
<b>Total</b>							<b>30</b>	<b>25</b>

4 <sup>th</sup> Semester								
<u>SL No</u>	<u>Type</u>	<u>Code</u>	<u>A. THEORY</u>	Contact hours				Cr. Points
				L	T	P	Total	
1	BS	M(CSE)401	Numerical Methods and Statistics	3	0	0	3	3
2	HS	HU401	Environmental science	2	0	0	2	2
3	PC	CS401	Computer Architecture	3	0	0	3	3
4	PC	CS402	Design and Analysis of Algorithms	3	0	0	3	3
5	PC	CS 403	Formal Language And Automata Theory	3	0	0	3	3
<b>Total Theory</b>							14	14
			<b><u>B. PRACTICAL</u></b>					
6	BS	M(CSE)491	Numerical Methods and Statistics Lab	0	0	3	3	2
7	PC	CS491	Computer Architecture Lab	0	0	3	3	2
8	PC	CS492	Algorithms Lab	0	0	3	3	2
9	PC	CS493	Programming with C++ Lab	1	0	2	3	2
<b>Total Practical</b>							12	8
			<b><u>C. MANDATORY COURSES</u></b>					
10	MC	MC 481	Technical Communication & Soft Skills	0	0	3	3	2 Unit
<b>Total</b>							<b>29</b>	<b>22</b>

SL No	5TH SEMESTER							Cr. Points
	Type	Code	A. THEORY	Contact hours				
				L	T	P	Total	
1	HS	HU 501	Economics for Engineers	2	0	0	2	2
2	PC	CS501	Computer Graphics	3	0	0	3	3
3	PC	CS502	Operating System	3	0	0	3	3
4	PC	CS503	Data Base Management System	3	0	0	3	3
5	FE	CS 504	A. Object Oriented Programming using Java B. Multimedia Technology C. Communication Engineering	3	0	0	3	3
6	PE	CS505	A. Operations Research B. Computational Geometry C. Digital Signal Processing	3	0	0	3	3
<b>Total Theory</b>							17	17
			<b>B. PRACTICAL</b>					
7	PC	CS591	Computer Graphics Lab	0	0	3	3	2
8	PC	CS592	Operating System Lab	0	0	3	3	2
9	PC	CS 593	Data Base Management System Lab	0	0	3	3	2
10	FE	CS594	A. Object Oriented Programming Lab B. Multimedia Technology Lab C. Communication Engineering Lab	0	0	3	3	2
11		CS 581	Mini Project	0	0	3	3	2
<b>Total Practical</b>							15	10
			<b>C. MANDATORY</b>					

			<b>COURSES</b>					
12	MC	MC58 1	General Aptitude /Foreign Language	0	0	3	3	2 Unit
<b>Total</b>							35	27

<b>6TH SEMESTER</b>								
<b>SL No</b>	<b>Type</b>	<b>Code</b>	<b>A. THEORY</b>	<b>Contact hours</b>				<b>Cr. Points</b>
				<b>L</b>	<b>T</b>	<b>P</b>	<b>Total</b>	
1	PC	CS601	Computer Network	3	0	0	3	3
2	PC	CS602	Microprocessor and Microcontroller	3	0	0	3	3
3	PC	CS603	Software Engineering	3	0	0	3	3
4	PE	CS604	A. Compiler Design B. Robotics C. Simulation and modeling	3	0	0	3	3
5	FE	CS 605	A. Pattern Recognition B. Distributed Operating System C. Distributed Database D. Computer Vision	3	0	0	3	3
6	FE	CS606	A. Data Warehousing and Data Mining B. Digital Image Processing C. E-commerce and ERP	3	0	0	3	3
<b>Total Theory</b>							18	18
<b>B. PRACTICAL</b>								
7	PC	CS691	Computer Network Lab	0	0	3	3	2
8	PC	CS692	Microprocessor and Microcontroller Lab	0	0	3	3	2
9	PC	CS693	Software Engineering Lab	0	0	3	3	2
<b>Total Practical</b>							9	6
<b>C. SESSIONAL</b>								
<b>10</b>		CS681	Group Discussion and Seminar	0	0	3	3	2

**Total**

30

26

<b>7TH SEMESTER</b>								
<b>SL No</b>	<b>Type</b>	<b>Code</b>	<b>A. THEORY</b>	<b>Contact hours</b>				<b>Cr. Points</b>
				<b>L</b>	<b>T</b>	<b>P</b>	<b>Total</b>	
1	HS	HU701	Values & Ethics in Profession	2	0	0	2	2
2	PC	CS701	Artificial Intelligence	3	0	0	3	3
3	PE	CS702	A. Soft Computing B. Natural Language Processing C. Web technology	3	0	0	3	3
4	PE	CS703	A. Cloud Computing B. Data Analytics C. Sensor Network and IOT	3	0	0	3	3
5	PE	CS704	A. Distributed Algorithms B. Bio-informatics C. Cryptography and Network Security	3	0	0	3	3
<b>Total Theory</b>							14	14
			<b>B. PRACTICAL</b>					
6	PC	CS791	Artificial Intelligence Lab	0	0	3	3	2
7	PE	CS792	A. Soft Computing Lab B. Natural Language Processing Lab C. Web Technology Lab	0	0	3	3	2
8		CS795	Project-1	0	0	3	3	2
<b>Total Practical</b>							9	6
			<b>C. SESSIONAL</b>					
9		CS781	Industrial Training	0	0	0	0	2
<b>Total Sessional</b>								
			<b>D. MANDATORY</b>					



			<b>COURSES</b>					
10	MC	MC781	Technical Skill Development	0	0	3	3	2Unit
<b>Total</b>							26	22

<b>8TH SEMESTER</b>								
				Contact hours				Cr. Points
<b>8th Semester</b>				L	T	P	Total	
<b>SL No</b>	<b>Type</b>	<b>Code</b>	<b>A. THEORY</b>					
1	HS	HU801	A. Principle of Management B. Organizational Behavior	2	0	0	2	2
2	PE	CS801	A. Mobile Computing B. Human computer Interaction C. Cyber Law and Security Policy D. VLSI Design	3	0	0	3	3
3	PE	CS802	A. Parallel Computing B. Machine Learning C. Real Time Operating System and Embedded System D. Advanced Computer Architecture	3	0	0	3	3
<b>Total Theory</b>							8	8
<b>B. PRACTICAL</b>								
4	PC	CS891	Design lab	0	0	3	3	2
5		CS892	Project 2	0	0	12	9	6
6		CS893	Seminar Presentation	0	0	3	3	2
<b>Total Practical</b>							18	12
<b>C. SESSIONAL</b>								
7		CS881	Grand Viva	0	0	0	0	4

<b>Total</b>							26	22
<b>Grand Total</b>								198

Category	Total Credit	Percentage of Proposed curriculum	Percentage according to AICTE	
			Min	Max
HS	13	6.56	5	10
BS	34	17.17	15	20
ES	35	17.67	15	20
PC	62	31.31	30	40
FE	11	5.55	5	10
PE	23	11.61	10	15
Project+etc	20	10.10	10	15
Grand Total	198			
MC	8 Unit			

# JIS College of Engineering

(An Autonomous Institution)

Department of Computer Science and Engineering

Full Curriculum and Syllabus of B.Tech. in Computer Science and Engineering

Programme under Autonomous Framework

1<sup>st</sup> to 8<sup>th</sup> Semester. September 2015 reprint following 5<sup>th</sup> BOS meeting dated 24.09.2015

**Total Credit- 219**

## 1<sup>st</sup> semester

<b>A. Theory</b>						
Sl. No.	Paper Code	Paper Name	Contact hours/week			Credit points
			L	T	P Total	
1	M(CSE)101	Engineering Mathematics-I	3	1	0 4	4
2	HU 101	Professional Communication	3	0	0 3	2
3	PH 101	Physics-I	3	0	0 3	3
4	CS 101	Computer Fundamentals & Application	3	0	0 3	3
5	ME 101	Engineering Mechanics	3	1	0 4	4
		<b>Total of Theory</b>			<b>17</b>	<b>16</b>
<b>B. Practical</b>						
Sl. No.	Paper Code	Paper Name	Contact hours/week			Credit points
			L	T	P Total	
1	ME 191	Workshop Practice	1	0	3 4	3
2	PH 191	Physics- I Lab	0	0	3 3	2
3	HU 191	Language Lab	0	0	3 3	2
4	ME 192	Engineering Drawing	0	0	3 3	3
5	CS 191	Computer Application Lab	0	0	3 3	2
6	XC181	NCC/NSS	0	0	3 3	1
		<b>Total of Practical</b>			<b>19</b>	<b>13</b>
		<b>Total of Semester</b>			<b>36</b>	<b>29</b>

## 2<sup>nd</sup> Semester

<b>A. Theory</b>						
Sl. No.	Paper Code	Paper Name	Contact hours/week			Credit points
			L	T	P Total	
1	M(CSE)201	Engineering Mathematics-II	3	1	0 4	4
2	CS 201	Programming in C	3	1	0 4	4
3	EC 201	Basic Electronics Engineering	3	0	0 3	3
4	EE 201	Basic Electrical Engineering	3	0	0 3	3
5	CH 201	Engineering Chemistry	3	0	0 3	3
		<b>Total of Theory</b>			<b>17</b>	<b>17</b>
<b>B. Practical</b>						
Sl. No.	Paper Code	Paper Name	Contact hours/week			Credit points
			L	T	P Total	
1	CH 291	Chemistry Lab	0	0	3 3	2
2	CS 291	Programming in C Lab	0	0	3 3	2
3	EC 291	Basic Electronics Lab	0	0	3 3	2
4	EE 291	Basic Electrical Lab	0	0	3 3	2
5	CS 292	Presentation Design Lab	0	0	3 3	2
		<b>Total of Practical</b>			<b>15</b>	<b>10</b>
		<b>Total of Semester</b>			<b>32</b>	<b>27</b>

# JIS College of Engineering

(An Autonomous Institution)

Department of Computer Science and Engineering

Full Curriculum and Syllabus of B.Tech. in Computer Science and Engineering

Programme under Autonomous Framework

1<sup>st</sup> to 8<sup>th</sup> Semester. September 2015 reprint following 5<sup>th</sup> BOS meeting dated 24.09.2015

## 3<sup>rd</sup> Semester

A. Theory							
Sl. No.	Paper Code	Paper Name	Contact hours/week			Credit points	
			L	T	P		Total
1	CS 301	Data Structure & Algorithms	3	1	0	4	4
2	CS 302	Digital Logic	3	1	0	4	4
3	PH 301	Physics –II	3	0	0	3	3
4	M(CSE)301	Engineering Mathematics-III	3	0	0	3	3
5	EE 301	Circuit Theory & Network Analysis	3	0	0	3	3
		<b>Total of Theory</b>				<b>17</b>	<b>17</b>
B. Practical							
Sl. No.	Paper Code	Paper Name	Contact hours/week			Credit points	
			L	T	P		Total
1	CS 391	Data Structure & Algorithm Lab	0	0	3	3	2
2	CS 392	Digital Logic Lab	0	0	3	3	2
3	PH 391	Physics –II Lab	0	0	3	3	2
4	CS 381	Innovative Mini Project-I	0	0	3	3	2
		<b>Total of Practical</b>				<b>12</b>	<b>8</b>
		<b>Total of Semester</b>				<b>29</b>	<b>25</b>

## 4<sup>th</sup> Semester

A. Theory							
Sl. No.	Paper Code	Paper Name	Contact hours/week			Credit points	
			L	T	P		Total
1	M(CS)401	Numerical Methods	3	0	0	3	3
2	CS 401	Computer Organisation	3	1	0	4	4
3	CS 402	Operation Research Method	3	0	0	3	3
4	EI 401	Microprocessors & Microcontrollers	3	1	0	4	4
5	EC 401	Communication Engg.	3	1	0	4	4
		<b>Total of Theory</b>				<b>18</b>	<b>18</b>
B. Practical							
Sl. No.	Paper Code	Paper Name	Contact hours/week			Credit points	
			L	T	P		Total
1	EI 491	Microprocessor & Microcontroller Lab	0	0	3	3	2
2	EC 491	Communication Engg Lab	0	0	3	3	2
3	M(CS)491	Numerical Analysis Lab	0	0	3	3	2
4	CS 492	Operation Research Lab	0	0	3	3	2
		<b>Total of Practical</b>				<b>12</b>	<b>8</b>
		<b>Total of Semester</b>				<b>30</b>	<b>26</b>

# JIS College of Engineering

(An Autonomous Institution)

Department of Computer Science and Engineering

Full Curriculum and Syllabus of B.Tech. in Computer Science and Engineering

Programme under Autonomous Framework

1<sup>st</sup> to 8<sup>th</sup> Semester. September 2015 reprint following 5<sup>th</sup> BOS meeting dated 24.09.2015

## 5<sup>th</sup> Semester

A. Theory							
Sl. No.	Paper Code	Paper Name	Contact hours/week				Credit points
			L	T	P	Total	
1	CS 501	Design & Analysis of Algorithm	3	1	0	4	4
2	CS 502	Operating System	3	1	0	4	4
3	CS 503	Computer Networks	3	1	0	4	4
4	CS 504	Computer Architecture	3	0	0	3	3
5	CS 505	Object Oriented Programming	3	0	0	3	3
		<b>Total of Theory</b>				<b>18</b>	<b>18</b>
B. Practical							
Sl. No.	Paper Code	Paper Name	Contact hours/week				Credit points
			L	T	P	Total	
1	CS 591	Design & Analysis of Algorithm Lab	0	0	3	3	2
2	CS 592	Operating Systems Lab	0	0	3	3	2
3	CS 593	Computer Networks Lab	0	0	3	3	2
4	CS 595	Object Oriented Programming Lab	0	0	3	3	2
5	HU 591	Language Practice Lab	0	0	3	3	2
		<b>Total of Practical</b>				<b>15</b>	<b>10</b>
		<b>Total of Semester</b>				<b>33</b>	<b>28</b>

## 6<sup>th</sup> Semester

A.Theory							
Sl. No.	Paper Code	Paper Name	Contact hours/week				Credit points
			L	T	P	Total	
1	CS 601	Database Management System	3	1	0	4	4
2	CS 602	Computer Graphics & Multimedia	3	0	0	3	3
3	CS 603	Software Engineering	3	0	0	3	3
4	CS 604	Web Technology	3	0	0	3	3
5	CS 605	Formal Language & Automata Theory	3	0	0	3	3
6	F.E. HU 601(E)	Business English	3	0	0	3	3
		<b>Total of Theory</b>				<b>19</b>	<b>19</b>
B. Practicals							
Sl. No.	Paper Code	Paper Name	Contact hours/week				Credit points
			L	T	P	Total	
1	CS 691	Database Management System Lab	0	0	3	3	2
2	CS 692	Computer Graphics & Multimedia Lab	0	0	3	3	2
3	CS 693	Software Engg lab	0	0	3	3	2
4	CS 694	Web Technology Lab	0	0	3	3	2
5	CS 681	Mini Project /Presentation	0	0	3	3	2
		<b>Total of Practicals</b>				<b>15</b>	<b>10</b>
		<b>Total of Semester</b>				<b>34</b>	<b>29</b>

# JIS College of Engineering

(An Autonomous Institution)

Department of Computer Science and Engineering

Full Curriculum and Syllabus of B.Tech. in Computer Science and Engineering

Programme under Autonomous Framework

1<sup>st</sup> to 8<sup>th</sup> Semester. September 2015 reprint following 5<sup>th</sup> BOS meeting dated 24.09.2015

## 7<sup>th</sup> Semester

<b>A. Theory</b>							
Sl. No.	Paper Code	Paper Name	Contact hours/week				Credit points
			L	T	P	Total	
1	HU 701	Values & Ethics in Profession	3	0	0	3	3
2	CS 701	Compiler Design	3	1	0	4	4
3	CS 702	Soft Computing	3	1	0	4	4
4	CS 703	Elective I A. Mobile Computing B. Distributed Operating Systems C. Cloud Computing D. E-Commerce E. CAD VLSI	3	1	0	4	4
5	CS 704	Elective II A. Natural Language Processing B. Distributed DBMS C. Robotics D. Internet Technology E. Artificial Intelligence	3	1	0	4	4
		<b>Total of Theory</b>				<b>19</b>	<b>19</b>
<b>B. Practical</b>							
Sl. No.	Paper Code	Paper Name	Contact hours/week				Credit points
			L	T	P	Total	
1	CS 791	Compiler Design Lab	0	0	3	3	2
2	CS 792	Soft Computing Lab	0	0	3	3	2
3	CS 781	Assigned Project	0	0	3	3	4
4	CS 782	Seminar-I	0	0	3	3	2
5	CS 783	Practical Training Evaluation	0	0	3	3	2
		<b>Total of Practical</b>				<b>15</b>	<b>12</b>
		<b>Total of Semester</b>				<b>34</b>	<b>31</b>

# JIS College of Engineering

(An Autonomous Institution)

Department of Computer Science and Engineering

Full Curriculum and Syllabus of B.Tech. in Computer Science and Engineering

Programme under Autonomous Framework

1<sup>st</sup> to 8<sup>th</sup> Semester. September 2015 reprint following 5<sup>th</sup> BOS meeting dated 24.09.2015

## 8<sup>th</sup> Semester

A. Theory							
Sl. No.	Paper Code	Paper Name	Contact hours/week				Credit points
			L	T	P	Total	
1	HU 801	Financial Management	3	1	0	4	4
2	CS 801	Elective III A. Network Security B. VLSI Design C. Data Warehousing & Data Mining D. Ad-hoc Networking	3	1	0	4	4
3	CS 802	Elective IV A. Cryptography B. Pattern Recognition C. Image Processing D. Internet Security	3	1	0	4	4
<b>Total of Theory</b>			<b>12</b>				<b>12</b>
B. Practical							
Sl. No.	Paper Code	Paper Name	Contact hours/week				Credit points
			L	T	P	Total	
1	CS 881	Assigned Project(Cont.)	0	0	3	3	8
2	CS 882	Seminar II	0	0	3	3	2
3	CS 883	Grand Viva	0	0	3	3	2
<b>Total of Practical</b>			<b>9</b>				<b>12</b>
<b>Total of Semester</b>			<b>21</b>				<b>24</b>

# JIS College of Engineering

(An Autonomous Institution)

Department of Computer Science and Engineering

Full Curriculum and Syllabus of B.Tech. in Computer Science and Engineering

Programme under Autonomous Framework

1<sup>st</sup> to 8<sup>th</sup> Semester. September 2015 reprint following 5<sup>th</sup> BOS meeting dated 24.09.2015

## 1<sup>st</sup> semester

A. Theory							
Sl. No.	Paper Code	Paper Name	Contact hours/week			Credit points	
			L	T	P		Total
1	M(CSE)101	Engineering Mathematics-I	3	1	0	4	4
2	HU 101	Professional Communication	3	0	0	3	2
3	PH 101	Physics-I	3	0	0	3	3
4	CS 101	Computer Fundamentals & Application	3	0	0	3	3
5	ME 101	Engineering Mechanics	3	1	0	4	4
		<b>Total of Theory</b>				<b>17</b>	<b>16</b>
B. Practical							
Sl. No.	Paper Code	Paper Name	Contact hours/week			Credit points	
			L	T	P		Total
1	ME 191	Workshop Practice	1	0	3	4	3
2	PH 191	Physics- I Lab	0	0	3	3	2
3	HU 191	Language Lab	0	0	3	3	2
4	ME 192	Engineering Drawing	0	0	3	3	3
5	CS 191	Computer Application Lab	0	0	3	3	2
6	XC181	NCC/NSS	0	0	3	3	1
		<b>Total of Practical</b>				<b>19</b>	<b>13</b>
		<b>Total of Semester</b>				<b>36</b>	<b>29</b>



# JIS College of Engineering

(An Autonomous Institution)

Department of Computer Science and Engineering

Full Curriculum and Syllabus of B.Tech. in Computer Science and Engineering

Programme under Autonomous Framework

1<sup>st</sup> to 8<sup>th</sup> Semester. September 2015 reprint following 5<sup>th</sup> BOS meeting dated 24.09.2015

## 1<sup>st</sup> Semester

**Paper Name: Engineering Mathematics-I**

**Code: M(CSE) 101**

**Contacts: 3L + 1T**

**Credits: 4**

**Allotted hours:42 L**

**Matrix:** Determinant of a square matrix, Minors and Cofactors, Laplace's method of expansion of a determinant, Product of two determinants, Adjoint of a determinant, Jacobi's theorem on adjoint determinant. Singular and non-singular matrices, Adjoint of a matrix, Inverse of a non-singular matrix and its properties, orthogonal matrix and its properties, Trace of a matrix. Rank of a matrix and its determination using elementary row and column operations.

**Infinite Series:** Preliminary idea of sequence, Infinite series and their convergences/divergences, Infinite series of positive terms, Tests for convergence: Comparison test, Cauchy's root test, D'Alembert's ratio test and Raabe's test. Alternating series, Leibnitz's test. Absolute convergence and Conditional convergence. Power series (Definition and Examples).

**Calculus of functions of single variable:** Successive differentiation : Higher order derivatives of a function single variable, Leibnitz's theorem (statements and its applications). Rolle's theorem and its applications. Mean value theorem- Lagrange & Cauchy and their application, Taylor's theorem with Lagrange's and Cauchy's form of remainders and its application, Taylor's and Maclaurin's theorem (Statements only), Maclaurin's infinite series expansion of functions:  $\sin x$ ,  $\cos x$ ,  $e^x$ ,  $\log(1+x)$ ,  $(1+x)^n$ ,  $n$  being an positive integer or a fraction (assuming that the remainder  $R_n \rightarrow 0$  as  $n \rightarrow \infty$  in each case). Reduction formulae both for indefinite and definite integrals of types

$$\int \sin^n x, \int \cos^n x, \int \sin^m x \cos^n x, \int \cos^m x \sin^n x, \int \frac{dx}{(x^2 + a^2)^n}, m, n$$

are positive integers.

**Calculus of functions of several variables:** Introduction to functions of several variables with examples, Knowledge of limit and continuity, Partial derivatives and related problems, Homogeneous functions and Euler's theorem and related problems up to three variables, Chain rules, Differentiation of implicit functions, Total differentials and their related problems, Jacobians up to three variables and related problems, Maxima, minima and saddle points of functions and related problems, Concept of line integrals, Double and triple integrals.

**Vector Calculus:** Scalar and vector fields . Vector function of a scalar variable, Differentiation of a vector function, Gradient of a scalar point function, Directional derivative. Divergence and curl of a vector point function and related problems . Green's Theorem, Gauss Divergence Theorem and Stoke's Theorem (Statements and Applications).

Suggested Reference Books:

1. Advanced Engineering Mathematics 8e by Erwin Kreyszig is published by Wiley India.
2. Engineering mathematics: B.S.Grewal (S.Chand & Co.).
3. higher Engineering Mathematics: John Bird (4<sup>th</sup> Edition, 1<sup>st</sup> India Reprint 2006, Elsevier.
4. mathematics Handbook : for Science and Engineering, L.Rade and B.Westergen (5<sup>th</sup> edition, 1<sup>st</sup> PstP Indian Edition 2009, Springer)
5. Calculus : M.J.Strauss, G.L.Bradly and K.L.Smith (3<sup>rd</sup> PstP, 1<sup>st</sup> PstP Indian Edition 2007, Pearson Education)
6. Engineering mathematics: S.S.Sastry (PHI, 4<sup>th</sup> PstP Edition, 2008)
7. Advanced Engineering Mathematics, 3<sup>rd</sup> E: J.L.Goldberg and E.F.Abonfadel (OUP), Indian Edition.

# JIS College of Engineering

(An Autonomous Institution)

Department of Computer Science and Engineering

Full Curriculum and Syllabus of B.Tech. in Computer Science and Engineering

Programme under Autonomous Framework

*1<sup>st</sup> to 8<sup>th</sup> Semester. September 2015 reprint following 5<sup>th</sup> BOS meeting dated 24.09.2015*

**Paper Name: Professional Communication**

**Code: HU 101**

**Contacts: 3L**

**Credits: 2**

**Allotted hours: 30L**

**Elements of Written Communication:** words and phrases, word formation, synonyms and antonyms, homophones, one word substitution, sentence construction, paragraph construction, tense, preposition, creative writing, voice change .8L

**Value-based Text Reading:**4L

(A) Study of the following essays from the text book with emphasis on writing skills:

1. The Thief by Ruskin Bond
2. The Open Window by Saki
3. Marriage is a private Affair by Chinua Achebe
4. The Moon in the Earthen Pot by Gopini Karunakar

**Fundamentals of Technical Communication :** process of communication, language as a tool of communication, levels of communication , flow of communication, barriers to communication, communication across cultures; Technical Communication: meaning, significance, characteristics, difference between technical and general communication.4L

**Forms of Technical Communication:** business letters, job application letter and resume, business letters: sales & credit letters, letters of enquiry, letters of quotation, order, claim and adjustment letters, official letters: D.O. letters, government letters, letters to authorities, etc. , Technical Reports: general format of a report, formal and informal reports, memo report, progress report, status report, survey report, trip report, trouble report, laboratory report, research papers, dissertations and theses.

Technical Proposals: purpose, characteristics, types, structure. 8L

**Presentation Strategies:** defining the subject, scope and purpose, analysing audience & locale, collecting materials, preparing outlines, organising the contents, visual aids, nuances of delivery, extemporaneous, manuscripts, impromptu, memorization and non- verbal strategies.6L

**BOOKS -- RECOMMENDED:**

1. Board of Editors: Contemporary Communicative English for Technical Communication Pearson Longman,2010
2. Dr. D. Sudharani: Manual for English Language Laboratory Pearson Education (W.B. edition), 2010
3. Technical Communication Principles and Practice by Meenakshi Raman, Sangeeta Sharma( Oxford Higher Education )
4. Effective Technical Communication by Barun K.Mitra( Oxford Higher Education )
5. V. Sashikumar (ed.): Fantasy- A Collection of Short Stories Orient Black swan (Reprint 2006)

# JIS College of Engineering

(An Autonomous Institution)

Department of Computer Science and Engineering

Full Curriculum and Syllabus of B.Tech. in Computer Science and Engineering

Programme under Autonomous Framework

1<sup>st</sup> to 8<sup>th</sup> Semester. September 2015 reprint following 5<sup>th</sup> BOS meeting dated 24.09.2015

**Paper Name: Physics-I**

**Code: PH 101**

**Contacts: 3L**

**Credits: 3**

**Allotted hours: 40L**

## **Module 1: Classical Mechanics**

**Classical Mechanics:** Limitations of Newtonian Mechanics, constraint, degree of freedom, generalized coordinates, Lagrange's equation (No derivation), Hamilton's principle, Applications of Lagrange's equation: Linear Harmonic Oscillators-Differential equation and its solution, superposition of two linear SHM's (with same frequency), Lissajous' figures. 4L

**Damped vibration:** Introduction – differential equation and its solution, critical damping, Logarithmic decrement. 1L

**Forced vibration:** Introduction – differential equation, Amplitude and velocity resonance, Sharpness of resonance and Quality factor, Application to L-C-R Circuit 2L

### **Electromagnetic theory-I:**

Development of electromagnetic theory, Electromagnetic spectrum, Concept of displacement current, Maxwell's field equations with physical significance, wave equation in free space, transverse nature of electromagnetic wave, electromagnetic waves in a charge free conducting medium, skin depth, Poynting's vector. 5L

## **Module 2: OPTICS 1:**

**Interference** – Conditions for sustained interference, Young's double slit as an example. Qualitative idea of Spatial and Temporal Coherence, Conservation of energy and intensity distribution, Fresnel's Biprism, thin films of uniform thickness (derivation) Newton's ring. 4L

**Diffraction of light** – Fresnel and Fraunhofer class. Fraunhofer diffraction for single slit and double slits (elementary treatment, Intensity distribution). Plane transmission grating (No deduction of the intensity distributions is necessary). Missing orders. Dispersive power, Rayleigh criterion (qualitative), Resolving power of grating (Definition and formulae). Use of grating as a monochromator. 3L

**Polarization:** General concept of Polarization, Plane of vibration and plane of polarization, Concept of Plane, Circularly and Elliptically polarized light (using wave equations), Polarization through reflection and Brewster's law, Double refraction (birefringence) -Ordinary and Extra-ordinary rays, Nicol's Prism. 3L

**Laser :** Spontaneous and Stimulated emission of radiation, Population inversion, Einstein's A & B coefficient (derivation of the mutual relation), concept of laser as a polarized source, Optical resonator and Condition necessary for active Laser action, Ruby Laser, He-Ne Laser, semiconductor Laser- applications of laser. 3L

**Fiber optics:** Optical Fibers – Core and cladding, total internal reflection step index and graded index fiber, Calculation of Numerical aperture and acceptance angle, losses in the fiber, applications. 2L

## **Module 3: Elementary solid state physics**

**Crystallography & Solid state physics:** Space lattice, unit cell, crystal systems, Bravais lattices, basis, coordination number and atomic packing fraction, scc, bcc and fcc and hcp structures lattice planes, indexing of directions, Miller indices, interplaner spacing, Bragg's law & its application to real crystal structure (NaCl, KCl). 4L

# JIS College of Engineering

(An Autonomous Institution)

Department of Computer Science and Engineering

Full Curriculum and Syllabus of B.Tech. in Computer Science and Engineering

Programme under Autonomous Framework

1<sup>st</sup> to 8<sup>th</sup> Semester. September 2015 reprint following 5<sup>th</sup> BOS meeting dated 24.09.2015

## Module 4: Quantum Mechanics I:

**Matter waves:** Concept of de Broglie's Matter waves, derivation of wavelength of matter waves in different forms, Concept of Phase velocity and Group velocity (qualitative) 2L

**Wave mechanics:** Concept and Physical significance of wave function  $\Psi$  and interpretation of  $|\Psi|^2$ ,  $\Psi$ (normalization and probability interpretation), Heisenberg's Uncertainty principle with illustration; Schrödinger's equation- time dependent and time independent form (derivation). Discussion with relevant problems. 3L

**Operator algebra:** Operator, Commutator, Formulation of quantum mechanics and Basic postulates, Operator correspondence, Expectation values, Ehrenfest theorem. Discussion with relevant problems. 4L

## List of recommended Books:

### Module 1: Experiments on Classical Mechanics:

1. Classical Mechanics- J. C. Upadhyay (Himalya Publishers)
2. Classical Mechanics-Shrivastav
3. Classical Mechanics-Takwal & Puranik (TMH)
4. Sound-N. K. Bajaj (TMH)
5. Advanced Acoustics-D. P. Roy Chowdhury (Chayan Publisher)
6. Principles of Acoustics-B.Ghosh (Sridhar Publisher)
7. A text book of sound-M. Ghosh ( S. Chand publishers)
8. Electromagnetics-B.B. Laud (TMH)
9. Electricity Magnetism-B.Ghosh ( Book & Allied Publisher)
10. Electricity Magnetism-Chattoopadhyay & Rakshit (New Central Book Agency)
11. A text book of Light- K.G. Mazumder & B.Ghosh, ( Book & Allied Publisher)
12. Electricity Magnetism-Fewkes and Yardwood (Oxford University Press)

### Module 2: OPTICS 1:

1. A text book of Light- K.G. Mazumder & B.Ghosh ( Book & Allied Publisher)
2. A text book of Light-Brijlal & Subhramanium, ( S. Chand publishers)
3. Modern Optics-A. B. Gupta ( Book & Allied Publisher)
4. Optics-Ajay Ghatak (TMH)
5. Optics-Hecht
6. Optics-R. Kar, Books Applied Publishers

### Module 3: Elementary solid state physics

1. Solid state physics-Puri & Babbar ( S. Chand publishers)
2. Materials Science & Engineering-Kakani Kakani
3. Solid state physics- S. O. Pillai
4. Introduction to solid state physics-Kittel (TMH)
5. Solid State Physics and Electronics-A. B. Gupta, Nurul Islam ( Book & Allied Publisher)

### Module 4: Quantum Mechanics I:

1. Introduction to Quantum Mechanics-S. N. Ghoshal (Calcutta Book House)
2. Quantum Mechanics-Bagde Singh (S. Chand Publishers)
3. Perspective of Quantum Mechanics-S. P. Kuilla (New Central Book Agency)
4. Quantum Mechanics-Binayak Datta Roy (S. Chand Publishers)
5. Quantum Mechanics-Bransden (Pearson Education Ltd.)
6. Perspective of Modern Physics-A. Beiser (TMH)

### General Reference:

1. Refresher courses in physics (Vol. 1, Vol. 2 & Vol. 3)-C. L. Arora (S. Chand Publishers)
2. Basic Engineering Physics-Amal Chakraborty (Chaya Prakashani Pvt. Ltd.)
3. Basic Engineering Physics-I -Sujoy Bhattacharya, Saumen Paul (TMH)
4. University Physics-Sears & Zemansky (Addison-Wesley)

# JIS College of Engineering

(An Autonomous Institution)

Department of Computer Science and Engineering

Full Curriculum and Syllabus of B.Tech. in Computer Science and Engineering

Programme under Autonomous Framework

*1<sup>st</sup> to 8<sup>th</sup> Semester. September 2015 reprint following 5<sup>th</sup> BOS meeting dated 24.09.2015*

**Paper Name: Computer Fundamentals & Application**

**Code: CS 101**

**Contacts: 3L**

**Credits: 3**

**Allotted hours: 36L**

Module-1:

- I. Basic overview of Computer ( Input Unit, Output Unit, Storage Unit, Arithmetic Logic Unit, Control Unit, Central Processing Unit, System Concept, Memory Management)
- II. Computer Generation
- III. Classification of Computers
- IV. Definition of Software, Relationship between Hardware and Software, Classification of Software
- V. Assembly language, high level language, compiler and assembler (basic concepts)
- VI. Data Processing [8L]

Module-2:

Number Systems:

- I. Non-positional Number System
- II. Positional Number System
- III. Decimal Number System, Binary Number System, Octal Number System, Hexadecimal Number System, BCD Number System
- IV. Converting from one number system to another number system
- VI. n's and (n-1)'s complement
- VII. Basic Arithmetic operation in binary number system [7L]

Module-3:

- I. Boolean algebra
- II. Logic Gates (AND, OR, NOT, NAND, NOR GATE) with truth table
- III. Logic circuits (combinational circuit)
- IV. Converting expression to logic circuit (By using universal NAND gate and NOR gate)
- V. Exclusive OR and equivalence function
- VI. Exclusive NOR and equivalence function [7L]

Module-4:

- I. Planning the computer programming
- II. Pseudo code, Examples of Pseudo code
- III. Flowcharts, Example of FlowCharts
- IV. Algorithm, Example of Algorithm [7L]

Module-5:

- I. Basic overview of Operating System
- II. Some popular operating Systems (LINUX, MS-DOS, Windows XP)
- III. Basic overview of Computer Networking
- IV. Network topologies, Basic Network model (PAN, LAN, MAN, WAN, CAN), protocols

[7L]

Reference:

1. Sinha, P.K. & Sinha, Priti, Computer Fundamentals, BPB
2. Fundamentals of computer by v rajaraman
3. M.M.Oka Computer Fundamentals, EPH

# JIS College of Engineering

(An Autonomous Institution)

Department of Computer Science and Engineering

Full Curriculum and Syllabus of B.Tech. in Computer Science and Engineering

Programme under Autonomous Framework

1<sup>st</sup> to 8<sup>th</sup> Semester. September 2015 reprint following 5<sup>th</sup> BOS meeting dated 24.09.2015

**Paper Name: Engineering Mechanics**

**Code: ME 101**

**Contacts: 3L+1T**

**Credits: 4**

**Allotted hours: 25L+8T**

SL. NO.	Syllabus	Contact Hrs	Reference Books & Chapters and Problems for practice
MOD-1	Importance of Mechanics in engineering; Introduction to Statics; Concept of Particle and Rigid Body; Types of forces: collinear, concurrent, parallel, concentrated, distributed; Vector and scalar quantities; Force is a vector; Transmissibility of a force (sliding vector).	2L	Meriam&Kraig: Vol-I Chapt: 1/1, 2/2,1/3
	Introduction to Vector Algebra; Parallelogramlaw; Addition and subtraction of vectors;Lami's theorem; Free vector; Bound vector;Representation of forces in terms of i,j,k; Crossproduct and Dot product and their applications.	4L+1T	1. Meriam&Kraig: Vol-I Chapt: 1/3, 2/4, 2/7 2. I.H. Shames Chapt: 2.1 to 2.8 Probs: 2.1, 2.2, 2.3,2.6, 2.10, 2.48, 2.52, 2.54, 2.64, 2.68
	Two dimensional force system; Resolution of forces; Moment; Varignon's theorem; Couple;Resolution of a coplanar force by its equivalent force-couple system; Resultant of forces.	4L+2T	1. Meriam&Kraig: Vol-I Chapt: 2/3, 2/4, 2/5, 2/6, 2/9 Probs: 2/1 to 2/8; 2/13, 2/16, 2/20; 2/27, 2/31 to 2/33, 2/35, 2/37, 2/39; 2/53, 2/55, 2/57, 2/61, 2/66; 2/75, 2/77, 2/79, 2/78 to 2/82; 2/135 to 2/137, 2/139, 2/141, 2/146, 2/147,2/151, 2/157
MOD-2	Concept and Equilibrium of forces in two dimensions; Free body concept and diagram; Equations of equilibrium.	3L+1T	Meriam&Kraig: Vol-I Chapt: 3/2, 3/3 Probs: 3/1, 3/3, 3/4 to 3/7, 3/11, 3/13, 3/15, 3/21, 3/25, 3/27, 3/31,3/39
	Concept of Friction; Laws of Coulomb friction; Angle of Repose; Coefficient of friction.	3L+1T	Meriam&Kraig: Vol-I Chapt: 6/1, 6/2, 6/3 Probs: 6/1 to 6/6, 6/13, 6/15, 6/17; 2. I.H. Shames; Chapt: 7.1,7.2

# JIS College of Engineering

(An Autonomous Institution)

Department of Computer Science and Engineering

Full Curriculum and Syllabus of B.Tech. in Computer Science and Engineering

Programme under Autonomous Framework

1<sup>st</sup> to 8<sup>th</sup> Semester. September 2015 reprint following 5<sup>th</sup> BOS meeting dated 24.09.2015

MOD-3	Distributed Force: Centroid and Centre of Gravity; Centroids of a triangle, circular sector, quadrilateral, composite areas consisting of above figures.	4L+1T	1. Meriam&Kraig: Vol-I Chapt: 5/1, 5/2, 5/3 Sample probs: 5/1 to 5/5 Probs: 5/2, 5/5, 5/7, 5/9, 5/12, 5/20, 5/25, 5/30, 5/43, 5/47
	Moments of inertia: MI of plane figure with respect to an axis in its plane, MI of plane figure with respect to an axis perpendicular to the plane of the figure; Parallel axis theorem; Mass moment of inertia of symmetrical bodies, e.g. cylinder, sphere, cone.	3L+1T	1. Meriam&Kraig: Vol-I Chapt: Appendix A/1, A/2 Sample Probs: A/1 to A/5; Probs: A/1, A/5, A/9, A/15, A/20
	Concept of simple stresses and strains: Normal stress, Shear stress, Bearing stress, Normal strain, Shearing strain; Hooke's law; Poisson's ratio; Stress-strain diagram of ductile and brittle materials; Elastic limit; Ultimate stress; Yielding; Modulus of elasticity; Factor of safety.	2L+1T	1. Elements of strength of Materials by Timoshenko & Young Chapt: 1.1, 1.2, 1.3, 2.2 Prob set 1.2 : Prob: 3, 4, 5, 8, 9, 10 Prob set 1.3: Prob: 1, 3, 5, 7 2. Nag & Chanda -3rd Part Chapt: 1.1, 1.2.1 to 1.2.3, 1.2.6, 1.2.7
MOD-4	Introduction to Dynamics: Kinematics and Kinetics; Newton's laws of motion; Law of gravitation & acceleration due to gravity; Rectilinear motion of particles; determination of position, velocity and acceleration under uniform and non-uniformly accelerated rectilinear motion; construction of x-t, v-t and a-t graphs.	3L+1T	Meriam&Kraig: Vol-II Chapt: 1/3, 1/5, 1/7, 2/1, 2/2 Probs: 1/1 to 1/10; 2/1 to 2/14; 2/15, 2/17, 2/19, 2/25, 2/27;
	Plane curvilinear motion of particles: Rectangular components (Projectile motion); Normal and tangential components (circular motion).	3L+1T	Meriam&Kraig: Vol-II Chapt: 2/3, 2/4, 2/5, Probs: 2/59 to 2/65, 2/67, 2/71, 2/81, 2/84, 2/89; 2/97, 2/99 to 2/103;
MOD-5	Kinetics of particles: Newton's second law; Equation of motion; D'Alembert's principle and free body diagram; Principle of work and energy; Principle of conservation of energy; Power and efficiency.	5L+2T	5L+2T Meriam&Kraig: Vol-II Chapt: 3/2, 3/3, 3/4, 3/6, 3/7; Probs: 3/1, 3/3, 3/4, 3/7, 3/11, 3/12; 3/17, 3/19, 3/23; 3/103 to 3/107, 3/113, 3/115, 3/116; Sample probs: 3/16, 3/17; Probs: 3/143, 3/145, 3/158 Books Recommended

# JIS College of Engineering

(An Autonomous Institution)

Department of Computer Science and Engineering

Full Curriculum and Syllabus of B.Tech. in Computer Science and Engineering

Programme under Autonomous Framework

1<sup>st</sup> to 8<sup>th</sup> Semester. September 2015 reprint following 5<sup>th</sup> BOS meeting dated 24.09.2015

**Paper Name: Workshop Practice**

**Code: ME 191**

**Contacts: 1L+3P**

**Credits: 3**

**Allotted hours: 12L**

## A. THEORETICAL PART

1. INTRODUCTION TO MANUFACTURING; Socio-economic role, Definition, Major grouping and Examples. - 1L
2. ENGINEERING MATERIALS; Classification / Major grouping, Physical, Chemical and Mechanical properties, Applications - 1L
3. DIFFERENT CONVENTIONAL MANUFACTURING PROCESSES MAINLY COVERING BASIC PRINCIPLES, DIFFERENT METHODS AND GENERAL APPLICATIONS; Manufacturing by forming /shaping from solid (input) to solid (product); Forging, Rolling, Drawing, Extrusion; Press tool work- Bending, Shearing, Drawing and Coining. - 3L
4. FORMING / SHAPING FROM LIQUID TO SOLID- CASTING; General principles, General classification or Types of casting; Sand mould casting- procedural steps and requirements; Pattern, Mould, Melting, Pouring, Solidification, Extracting and Fettling. Other casting processes (for larger volume and quality); Centrifugal casting, Investment casting, Die casting. -3L
5. JOINING PROCESSES; Welding (Permanent Joining)- General classification and basis; Gas welding, Arc welding, Friction welding and Resistance welding, w.r.t. Principle, Requirements, Relative Advantages and Applications; Brazing and soldering. - 2L
6. REMOVAL (MACHINING) PROCESS; Principle and purpose of machining, Machining requirements, Machine tools- Definition, General classification w.r.t. functional principles and applications; Major machining parameters (and responses)- Speed, Feed and Depth of cut; Tool geometry (Rake, Clearance and Cutting angles), Cutting fluid application; Elementary machining operations- Facing, Centering, Turning, Threading, Drilling, Boring, Shaping and Milling. -2L

## B. SCHEDULE OF PRACTICAL CLASSES

Suggested apportionment / weigtage:

- Machining (and fitting)- 50% (6 days ) 18 hrs
- Casting (including pattern making molding and preparation) - 25% (3 days 9hrs)
- Welding (gas, arc and resistance) (2 days 6hrs) and Sheet Metal Working (1 day 3hr)- 25% (3 days 9hrs)

## FEASIBLE TYPES / MODELS OF ASSIGNMENTS

- i) FITTING (in 2 days or 6 hours); Making a gauge from MS plate as shown in Fig.1.

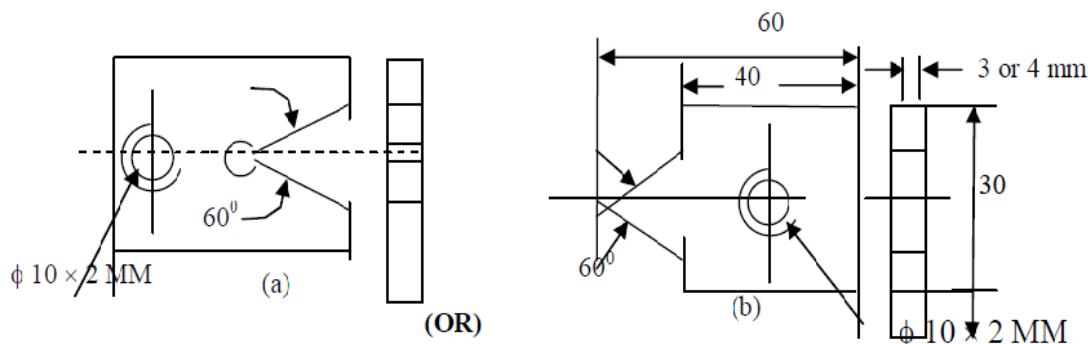

Fig.1: Job for fitting practice

Operations required:

11. Squaring and finishing of the blank by filing
12. Making the Vee-portion by sawing and filing
13. Drilling (in machine) and tapping (hand)

- ii) MACHINING (in 3 days or 9 hours); To make a pin as shown in Fig.2 from a  $\square 20$ mm mild steel rod in



# JIS College of Engineering

(An Autonomous Institution)

Department of Computer Science and Engineering

Full Curriculum and Syllabus of B.Tech. in Computer Science and Engineering

Programme under Autonomous Framework

1<sup>st</sup> to 8<sup>th</sup> Semester. September 2015 reprint following 5<sup>th</sup> BOS meeting dated 24.09.2015

a lathe.

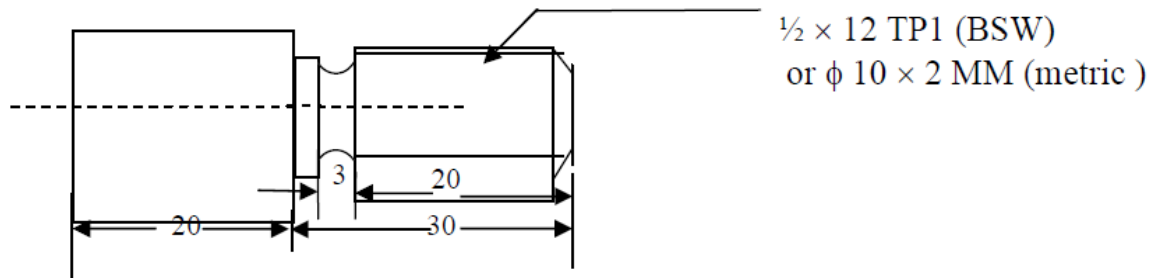

Fig.2: Job for practice on a lathe

iii) MACHINING (in 1 day or 3 hours); To make a MS prism as shown in Fig.3 from a  $\square 20$ mm mild steel rod in a shaping and / or milling machine.

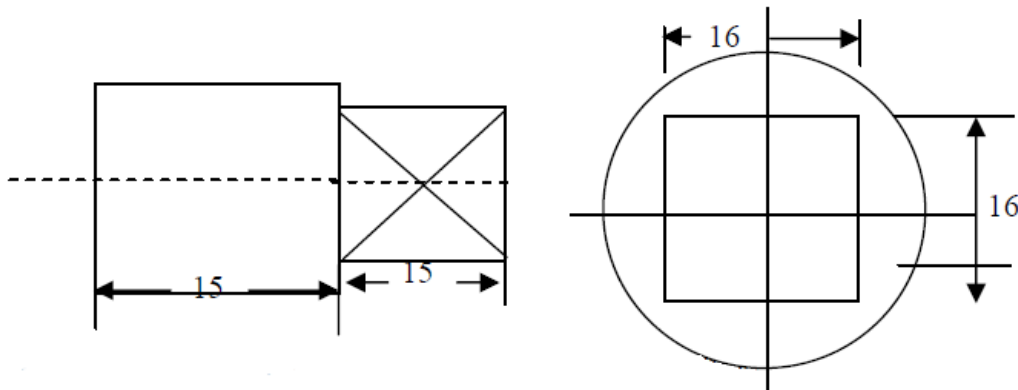
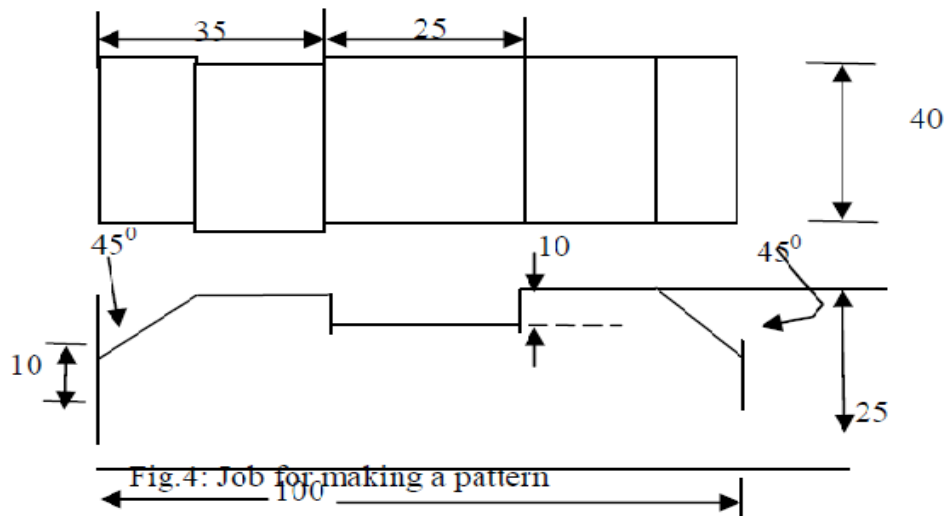

Fig.3: Job for practice on a shaping and/or milling machine

iv) PATTERN MAKING, SAND MOULDING AND CASTING (in 3 classes or 9 hours); To make a wooden pattern and a sand mould with that pattern for casting a cast iron block as shown in Fig.4.



v) WELDING (GAS WELDING) (in 1 class or 3 hours); To join two thin mild steel plates or sheets (1 to 3 mm thick) as shown in Fig. 5 by gas welding.

# JIS College of Engineering

(An Autonomous Institution)

Department of Computer Science and Engineering

Full Curriculum and Syllabus of B.Tech. in Computer Science and Engineering

Programme under Autonomous Framework

1<sup>st</sup> to 8<sup>th</sup> Semester. September 2015 reprint following 5<sup>th</sup> BOS meeting dated 24.09.2015

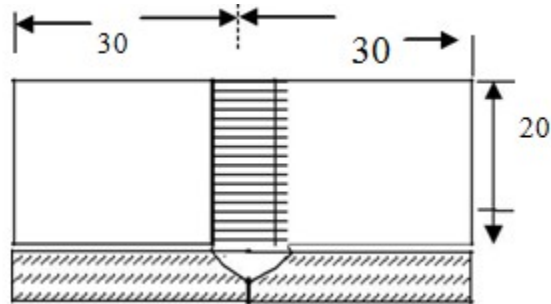

Fig.5: Welding specimen for practice

- vi) WELDING (ARC WELDING) (in 1 day or 3 hours); To join two thick (6mm) MS plate as shown in Fig. 5 by arc welding.
- vii) SHEET METAL WORK (in 1 day or 3 hours); forming a cone, for example.

# JIS College of Engineering

(An Autonomous Institution)

Department of Computer Science and Engineering

Full Curriculum and Syllabus of B.Tech. in Computer Science and Engineering

Programme under Autonomous Framework

1<sup>st</sup> to 8<sup>th</sup> Semester. September 2015 reprint following 5<sup>th</sup> BOS meeting dated 24.09.2015

**Paper Name: Physics I Lab**

**Code: PH 191**

**Contacts: 3P**

**Credits: 2**

## **General idea about Measurements and Errors (Mandatory):**

Measurand (objects to be measured), precision, accuracy, certainty, resolution; Errors - types and sources of errors (definitions and examples), Systematic error, Random error, Ambiguity error, Dynamic error, with example of Slide calipers, Screw-gauge, Carrey Foster bridge. Study of different types of unit cells with model system.

Any 7 to be performed from the following experiments

## **Experiments on Classical Mechanics:**

1. Study of torsional oscillation of torsional pendulum & determination of time period using various load of the oscillator.
2. Experiments on Lissajous figure (using CRO).
3. Experiments on LCR circuit.

## **Experiments on Optics:**

4. Determination of wavelength of light by Newton's ring method.
5. Determination of wavelength of light by Fresnel's bi-prism method.
6. Determination of wavelength of light by Laser diffraction method.
7. Determination of numerical aperture and the energy losses related to optical fibre experiment
8. Study of Hydrogen/ Helium spectrum using transmission grating and measurement of Rydberg Constant.
9. Inspection of Laser beam profile-to find beam divergence.
10. Study of half-wave and quarter wave plates.

## **Experiments on electromagnetic theory:**

11. Measurement of nodal and antinodal points along a transmission wire and measurement of wave length.

## **Experiments on Quantum Mechanics I**

12. Verification of Bohr's atomic orbital theory through Frank-Hertz experiment.
13. Measurement of Stopping potential using a photocell and determination of Planck's Constant.

## **List of recommended Books:**

### **Module 1: Experiments on Classical Mechanics:**

1. Classical Mechanics- J. C. Upadhyay (Himalya Publishers)
2. Classical Mechanics-Shrivastav
3. Classical Mechanics-Takwal & Puranik (TMH)
4. Sound-N. K. Bajaj (TMH)
5. Advanced Acoustics-D. P. Roy Chowdhury (Chayan Publisher)
6. Principles of Acoustics-B.Ghosh (Sridhar Publisher)
7. A text book of sound-M. Ghosh ( S. Chand publishers)
8. Electromagnetics-B.B. Laud (TMH)
9. Electricity Magnetism-B.Ghosh ( Book & Allied Publisher)
10. Electricity Magnetism-Chattohadhyay & Rakshit (New Central Book Agency)
11. A text book of Light- K.G. Mazumder & B.Ghoshs, ( Book & Allied Publisher)
12. Electricity Magnetism-Fewkes and Yardwood (Oxford University Press)

### **Module 2: OPTICS 1:**

1. A text book of Light- K.G. Mazumder & B.Ghoshs ( Book & Allied Publisher)
2. A text book of Light-Brijlal & Subhramanium, ( S. Chand publishers)
3. Modern Optics-A. B. Gupta ( Book & Allied Publisher)
4. Optics-Ajay Ghatak (TMH)
5. Optics-Hecht
6. Optics-R. Kar, Books Applied Publishers

### **Module 3: Elementary solid state physics**

1. Solid state physics-Puri & Babbar ( S. Chand publishers)
2. Materials Science & Engineering-Kakani Kakani
3. Solid state physics- S. O. Pillai
4. Introduction to solid state physics-Kittel (TMH)

# JIS College of Engineering

(An Autonomous Institution)

Department of Computer Science and Engineering

Full Curriculum and Syllabus of B.Tech. in Computer Science and Engineering

Programme under Autonomous Framework

*1<sup>st</sup> to 8<sup>th</sup> Semester. September 2015 reprint following 5<sup>th</sup> BOS meeting dated 24.09.2015*

5. Solid State Physics and Electronics-A. B. Gupta, Nurul Islam ( Book & Allied Publisher)

**Module 4: Quantum Mechanics I:**

1. Introduction to Quantum Mechanics-S. N. Ghoshal (Calcutta Book House)
2. Quantum Mechanics-Bagde Singh (S. Chand Publishers)
3. Perspective of Quantum Mechanics-S. P. Kuilla (New Central Book Agency)
4. Quantum Mechanics-Binayak Datta Roy (S. Chand Publishers)
5. Quantum Mechanics-Bransden (Pearson Education Ltd.)
6. Perspective of Modern Physics-A. Beiser (TMH)

**General Reference:**

1. Refresher courses in physics (Vol. 1, Vol. 2 & Vol. 3)-C. L. Arora (S. Chand Publishers)
2. Basic Engineering Physics-Amal Chakraborty (Chaya Prakashani Pvt. Ltd.)
3. Basic Engineering Physics-I -Sujoy Bhattacharya, Saumen Paul (TMH)
4. University Physics-Sears & Zemansky (Addison-Wesley)

# JIS College of Engineering

(An Autonomous Institution)

Department of Computer Science and Engineering

Full Curriculum and Syllabus of B.Tech. in Computer Science and Engineering

Programme under Autonomous Framework

*1<sup>st</sup> to 8<sup>th</sup> Semester. September 2015 reprint following 5<sup>th</sup> BOS meeting dated 24.09.2015*

**Paper Name: Language Lab**

**Code: HU 191**

**Contacts: 3P**

**Credits: 2**

## LANGUAGE LABORATORY PRACTICE

- a) Honing 'Listening Skill' and its sub skills through Language Lab Audio device; 3P
- b) Honing 'Speaking Skill' and its sub skills; 2P
- c) Helping them master Linguistic/Paralinguistic features (Pronunciation/Phonetics/Voice modulation/Stress/Intonation/ Pitch & Accent) of connected speech; 2P
- j) Honing 'Conversation Skill' using Language Lab Audio –Visual input; Conversational Practice Sessions (Face to Face / via Telephone , Mobile phone & Role Play Mode); 2P
- k) Introducing 'Group Discussion' through audio –Visual input and acquainting them with key strategies for success; 2P
- f) G D Practice Sessions for helping them internalize basic Principles (turn- taking, creative intervention, by using correct body language, courtesies & other soft skills) of GD; 4P
- g) Honing 'Reading Skills' and its sub skills using Visual / Graphics/Diagrams /Chart Display/Technical/Non Technical Passages; Learning Global / Contextual / Inferential Comprehension; 2P
- h) Honing 'Writing Skill' and its sub skills by using Language Lab Audio –Visual input; Practice Sessions 2P

Books Recommended:

Dr. D. Sudharani: Manual for English Language Laboratory

Pearson Education (WB edition),2010

Board of Editors: Contemporary Communicative English for Technical Communication, Pearson Longman, 2010

**Paper Name: Engineering Drawing**

**Code: ME 192**

**Contacts: 1L+3P**

**Credits: 3**

**Allotted hours: 12L**

## A. THEORETICAL PART

1. Introduction to Lines, Lettering, Dimensioning, Scales. - 1L
2. Geometrical Construction and Curves - 1L
3. Projection of Points, Lines and Surfaces - 2L
4. Projection of Solids - 2L
5. Isometric Views - 1L
6. Sectional Views - 1L
7. Development of Surfaces - 1L
8. Introduction to Computer Aided Drafting - 3L

## B. PRACTICAL PART

1. LINES, LETTERING, DIMENSIONING, SCALES; Plain scale, Diagonal scale. - 6hrs
2. GEOMETRICAL CONSTRUCTION AND CURVES; Construction of polygons, Parabola, Hyperbola, Ellipse. - 6hrs

# JIS College of Engineering

(An Autonomous Institution)

Department of Computer Science and Engineering

Full Curriculum and Syllabus of B.Tech. in Computer Science and Engineering

Programme under Autonomous Framework

1<sup>st</sup> to 8<sup>th</sup> Semester. September 2015 reprint following 5<sup>th</sup> BOS meeting dated 24.09.2015

3. PROJECTION OF POINTS, LINES, SURFACES; Orthographic projection- 1<sup>st</sup> and 3<sup>rd</sup> angle projection, Projection of lines and surfaces– Hexagon. - 3hrs
4. PROJECTION OF SOLIDS; Cube, Pyramid, Prism, Cylinder, Cone. - 6hrs
5. DRAWING ISOMETRIC VIEW FROM ORTHOGONAL/ SECTIONAL VIEWS OF SIMPLE SOLID OBJECTS. - 3hrs
6. FULL AND HALF SECTIONAL VIEWS OF SOLIDS. - 3hrs
7. DEVELOPMENT OF SURFACES; Prism, Cylinder, Cone. - 3hrs
8. COMPUTER AIDED DRAFTING (Using AutoCAD and/or similar softwares); Introduction: Cartesian and Polar coordinate system, Absolute and Relative coordinates; Basic editing commands: Line, Point, Trace, Rectangle, Polygon, Circle, Arc, Ellipse, Polyline; Editing methods; Basic object selection methods, Window and crossing window, Erase, Move, Copy, Offset, Fillet, Chamfer, Trim, Extend, Mirror; Display commands: Zoom, Pan, Redraw, Regenerate; Simple dimensioning and text, Simple exercises. - 6hrs

## References / Books:

1. Narayana, K.L. and Kannaiah, P. Text Book of Engineering Drawing“Engineering Graphics”, Scitech Publication
2. Bhatt, N.D. “Elementary Engineering Drawing”, Charotar Book Stall, Anand, 1998
3. Lakshminarayanan, V. and Vaish Wanar, R.S., “Engineering Graphics”, Jain Brothers, New Delhi, 1998
4. Chandra, A.M. and Chandra Satish, “Engineering Graphics”, Narosa, 1998
5. Jolhe, “Engineering Graphics”, Tata McGraw-Hill- WBUT Series
6. Gill, P.S., “A Text Book of Engineering Drawing”, Katson Publishing House (Kataria and Sons)
7. Venugopal, K., “Engineering Drawing & Graphics + AutoCAD”, New Age International
8. Ventaka Reddy K., “Text Book of Engineering Drawing (2<sup>nd</sup> Edition)”, BS Publication

## Paper Name: Computer Application Lab

**Code: CS 191**

**Contacts: 3P**

**Credits: 2**

### Module 1:

I. MS-Windows: Operating system-Definition & functions, basics of Windows. Basic components of windows, icons, types of icons, taskbar, activating windows, using desktop, title bar, running applications, exploring computer, managing files and folders, copying and moving files and folders. Control panel – display properties, adding and removing software and hardware, setting date and time, screensaver and appearance. Using windows accessories.

### II. Project-I.

### Module 2:

I. Documentation Using MS-Word - Introduction to Office Automation, Creating & Editing Document, Formatting Document, Auto-text, Autocorrect, Spelling and Grammar Tool, Document Dictionary, Page Formatting, Bookmark, Advance Features of MS-Word-Mail Merge, Macros, Tables, File Management, Printing, Styles, linking and embedding object, Template.

### II. Project-II.

### Module 3:

I. Electronic Spread Sheet using MS-Excel - Introduction to MS-Excel, Creating & Editing Worksheet, Formatting and Essential Operations, Formulas and Functions, Charts, Advance features of MS-Excel-Pivot

# JIS College of Engineering

(An Autonomous Institution)

Department of Computer Science and Engineering

Full Curriculum and Syllabus of B.Tech. in Computer Science and Engineering

Programme under Autonomous Framework

*1<sup>st</sup> to 8<sup>th</sup> Semester. September 2015 reprint following 5<sup>th</sup> BOS meeting dated 24.09.2015*

table & Pivot Chart, Linking and Consolidation, Database Management using Excel-Sorting, Filtering, Table, Validation, Goal Seek, Scenario.

II. Project-III.

Module 4:

I. Presentation using MS-PowerPoint: Presentations, Creating, Manipulating & Enhancing Slides, Organizational Charts, Excel Charts, Word Art, Layering art Objects, Animations and Sounds, Inserting Animated Pictures or Accessing through Object, Inserting Recorded Sound Effect or In-Built Sound Effect.

II. Project-IV.

**Paper Name: NCC/NSS**

**Code: XC181**

**Contacts: 3P**

**Credits: 1**

- a) Creating awareness in social issues
- b) Participating in mass education programmes
- c) Proposal for local slum area development
- d) Waste disposal
- e) Environmental awareness
- f) Production Oriented Programmes
- g) Relief & Rehabilitation work during Natural calamities

Creating awareness in social issues:

1. Women's development – includes health, income-generation, rights awareness.
2. Hospital activities – Eg. writing letters for patients, guiding visitors
3. Old age home – visiting the aging in-mates, arranging for their entertainment.
4. Children's Homes - visiting the young in-mates, arranging for their entertainment
5. Linking with NGOs to work on other social issues. (Eg. Children of sex-workers)
6. Gender issues- Developing an awareness, to link it with Women's Cell of college

Participating in mass education programmes

1. Adult education
2. Children's education

Proposal for local slum area development

One or two slums to be identified and according to the needs, activities to be developed and proposals and reports are to be submitted.

Environmental awareness

- Resource conservation – Awareness to be developed on water, energy, soil.
- Preservation of heritage monuments- Marches, poster campaigns
  
- Alternative energy consciousness amongst younger school-children.
- Plantation and beautification- Plantation of trees, their preservation and upkeep, developing NSS parks.
- Waste disposal- Proper methods of domestic waste disposal.

Production Oriented Programmes

5. Working with people and explaining and teaching improved agricultural practices
6. Rodent control land pest control practices;
7. Soil-testing, soil health care and soil conservation;
8. Assistance in repair of agriculture machinery;
9. Work for the promotion and strengthening of cooperative societies in villages;
10. Assistance and guidance in poultry farming, animal husbandry, care of animal health etc.;
11. Popularization of small savings and
12. Assistance in procuring bank loans

Relief & Rehabilitation work during Natural calamities

- g) Assisting the authorities in distribution of rations, medicine, clothes etc.;
- h) Assisting the health authorities in inoculation and immunization, supply of medicine etc.;

# **JIS College of Engineering**

(An Autonomous Institution)

Department of Computer Science and Engineering

Full Curriculum and Syllabus of B.Tech. in Computer Science and Engineering

Programme under Autonomous Framework

*1<sup>st</sup> to 8<sup>th</sup> Semester. September 2015 reprint following 5<sup>th</sup> BOS meeting dated 24.09.2015*

- i) Working with the local people in reconstruction of their huts, cleaning of wells, building roads etc.;
- j) Assisting and working with local authorities in relief and rescue operation;  
Collection of clothes and other materials, and sending the same to the affected areas;



# JIS College of Engineering

(An Autonomous Institution)

Department of Computer Science and Engineering

Full Curriculum and Syllabus of B.Tech. in Computer Science and Engineering

Programme under Autonomous Framework

1<sup>st</sup> to 8<sup>th</sup> Semester. September 2015 reprint following 5<sup>th</sup> BOS meeting dated 24.09.2015

## 2<sup>nd</sup> Semester

<b>A. Theory</b>							
Sl. No.	Paper Code	Paper Name	Contact hours/week			Credit points	
			L	T	P		Total
1	M(CSE)201	Engineering Mathematics-II	3	1	0	4	4
2	CS 201	Programming in C	3	1	0	4	4
3	EC 201	Basic Electronics Engineering	3	0	0	3	3
4	EE 201	Basic Electrical Engineering	3	0	0	3	3
5	CH 201	Engineering Chemistry	3	0	0	3	3
		<b>Total of Theory</b>				<b>17</b>	<b>17</b>
<b>B. Practical</b>							
Sl. No.	Paper Code	Paper Name	Contact hours/week			Credit points	
			L	T	P		Total
1	CH 291	Chemistry Lab	0	0	3	3	2
2	CS 291	Programming in C Lab	0	0	3	3	2
3	EC 291	Basic Electronics Lab	0	0	3	3	2
4	EE 291	Basic Electrical Lab	0	0	3	3	2
5	CS 292	Presentation Design Lab	0	0	3	3	2
		<b>Total of Practical</b>				<b>15</b>	<b>10</b>
		<b>Total of Semester</b>				<b>32</b>	<b>27</b>

# JIS College of Engineering

(An Autonomous Institution)

Department of Computer Science and Engineering

Full Curriculum and Syllabus of B.Tech. in Computer Science and Engineering

Programme under Autonomous Framework

1<sup>st</sup> to 8<sup>th</sup> Semester. September 2015 reprint following 5<sup>th</sup> BOS meeting dated 24.09.2015

## 2<sup>nd</sup> Semester

**Paper Name: Engineering Mathematics-II**

**Code: M(CSE) 201**

**Contacts: 3L + 1T**

**Credits: 4**

**Allotted hours: 40L**

There will be three groups in the question paper. In Group A, there will be one set of multiple choice type questions spreading the entire syllabus from which 10 questions (each carrying one mark) are to be answered. From Group B, three questions (each carrying 5 marks) are to be answered out of a set of questions covering all the three modules. Three questions (each carrying 15 marks) are to be answered from Group C. Each question of Group C will have three parts covering not more than two topics (marked in bold italics faces). Sufficient questions should to be set covering all modules.

### Module I

Ordinary differential equations (ODE)- First order and first degree: Exact equations, Necessary and sufficient condition of exactness of a first order and first degree ODE (statement only), Rules for finding Integrating factors, Linear equation, Bernoulli's equation. General solution of ODE of first order and higher degree (different forms with special reference to Clairaut's equation). 5L

### Module II

ODE- Higher order and first degree: General linear ODE of order two with constant coefficients, C.F. & P.I., D-operator methods for finding P.I., Method of variation of parameters, Cauchy-Euler equations, Solution of simultaneous linear differential equations. 6L

### Module III

Basics of Graph Theory: Graphs, Digraphs, Weighted graph, Connected and disconnected graphs, Complement of a graph, Regular graph, Complete graph, Sub graph,; Walks, Paths, Circuits, Euler Graph, Cut sets and cut vertices, Matrix representation of a graph, Adjacency and incidence matrices of a graph, Graph isomorphism, Bipartite graph. 10L

### Module IV

Tree: Definition and properties, Binary tree, Spanning tree of a graph, Minimal spanning tree, properties of trees, Algorithms: Dijkstra's Algorithm for shortest path problem, Determination of minimal spanning tree using DFS, BFS, Kruskal's and Prim's algorithms. 6L

### Module V

Improper Integral: Basic ideas of improper integrals, working knowledge of Beta and Gamma functions (convergence to be assumed) and their interrelations. 3L

**Laplace Transform (LT):** Definition and existence of LT, LT of elementary functions, First and second shifting properties, Change of scale property; LT of  $\frac{f(t)}{t}$ , LT of  $t^n f(t)$ , LT of derivatives of  $f(t)$ ,

L.T. of  $\int f(u)du$ . Evaluation of improper integrals using LT, LT of periodic and step functions, Inverse

LT: Definition and its properties; Convolution Theorem (statement only) and its application to the evaluation of inverse LT, Solution of linear ODE with constant coefficients (initial value problem) using LT. **10L**

# JIS College of Engineering

(An Autonomous Institution)

Department of Computer Science and Engineering

Full Curriculum and Syllabus of B.Tech. in Computer Science and Engineering

Programme under Autonomous Framework

*1<sup>st</sup> to 8<sup>th</sup> Semester. September 2015 reprint following 5<sup>th</sup> BOS meeting dated 24.09.2015*

## Suggested Reference Books:

1. Advanced Engineering Mathematics, Erwin Kreyszig, (Wiley Eastern)
2. Graph Theory: V. K. Balakrishnan, (Schaum's Outline, TMH)
3. A first course at Graph Theory: J. Clark and D. A. Holton (Allied Publishers LTD)
4. Introduction to Graph Theory: D. B. West (Prentice-Hall of India)
5. Graph Theory: N. Deo (Prentice-Hall of India)
6. Engineering Mathematics: B.S. Grewal (S. Chand & Co.)
7. Higher Engineering Mathematics: John Bird (4th Edition, 1st Indian Reprint 2006, Elsevier)
8. Calculus: Strauss, Bradley and Smith (3rd Edition, Pearson Education)
9. Engineering Mathematics (Volume 2): S. S. Sastry (Prentice-Hall of India)
10. Advanced Engineering Mathematics, 3E: M.C. Potter, J.L. Goldberg and E.F. Abonfadel (OUP), Indian Edition
11. An Introduction to Differential Equations, R.K. Ghosh and K.C. Maity (New Central Book Agency)

**Paper Name: Programming in C**

**Code: CS 201**

**Contacts: 3L + 1T**

**Credits: 4**

**Allotted hours: 41L**

## Basic Overview of Languages:

Language Introduction: Assembly language, high level language, middle level language, Basic overview of compiler, loader, linker and assembler, Algorithm & flow chart. 3L

## C Fundamentals:

The C character set identifiers and keywords, data types & sizes, variable names, declaration, definition, statements. 3L

Operators & Expressions: Arithmetic operators, relational/conditional operators, logical operators, increment and decrement operators, bit wise operators, assignment operators and expressions, precedence and order of evaluation, type conversion, enumeration. 4L

Input and Output: Standard input and output, formatted output: printf, formatted input scanf, gets, puts, getch, putchar, getc, putc. 4L

Flow of Control: Statement and blocks, if - else, nested if – else, switch-case loops: while, for, do while, break and continue, goto and labels. 4L

## Fundamentals and Program Structures:

Basic of functions, function types, functions returning values, functions not returning values, call by value, call by reference, auto, external, static and register variables, scope rules, recursion, iteration, function prototypes, C pre-processor directives, command line arguments. 7L

## Arrays and Pointers:

One dimensional arrays, multi-dimensional arrays, basic applications of array, pointers, pointers type, pointer arithmetic. 6L

# JIS College of Engineering

(An Autonomous Institution)

Department of Computer Science and Engineering

Full Curriculum and Syllabus of B.Tech. in Computer Science and Engineering

Programme under Autonomous Framework

1<sup>st</sup> to 8<sup>th</sup> Semester. September 2015 reprint following 5<sup>th</sup> BOS meeting dated 24.09.2015

## Structures Union:

Basic of structures, structure and functions, array of structures, basic of union, function and union, array of union. 5L

## Files:

Basic file functions, Bit fields, formatted and unformatted files, file permission, file input & output. 5L

## Recommended reference Books:

Introduction To Computing, E. Balagurusamy, TMH  
Kernighan, B.W. The Elements of Programming Style  
Schied F.S. Theory and Problems of Computers and Programming  
Gottfried Programming with C Schaum  
Kernighan B.W. & Ritchie D.M. The C Programming Language  
Rajaraman V. Fundamental of Computers  
Kanetkar Y. Let us C

## Paper Name: Basic Electronics Engineering

Code: EC 201

Contacts: 3L

Credits: 3

Allotted hours: L

Pre-requisites: Knowledge of Class XII level electronics, Physics & Mathematics.

Recapitulation and Orientation lectures:

Semiconductors: Conductors, Semiconductors and Insulators: electrical properties, band diagrams. Semiconductors: intrinsic and extrinsic, energy band diagram, electrical conduction phenomenon, P-type and N-type semiconductors, drift and diffusion carriers.

Diodes and Diode Circuits: Formation of P-N junction, energy band diagram, built-in potential forward and reverse biased P-N junction, formation of depletion zone, V-I characteristics, Zener breakdown, Avalanche breakdown and its reverse characteristics; Junction capacitance and Varactor diode. Simple diode circuits, load line, linear piecewise model; Rectifier circuits: half wave, full wave, PIV, DC voltage and current, ripple factor, efficiency, idea of regulation.

Bipolar Junction Transistors: Formation of PNP / NPN junctions, energy band diagram; transistor mechanism and principle of transistors, CE, CB, CC configuration, transistor characteristics: cut-off active and saturation mode, transistor action and current amplification factors for CB and CE modes. Biasing and Bias stability.

Field Effect Transistors: Concept of Field Effect Transistors (channel width modulation), Gate isolation types, JFET Structure and characteristics, MOSFET Structure and characteristics, depletion and enhancement type; CS, CG, CD configurations; CMOS: Basic Principles. Feed Back Amplifier (basic concept), Oscillators and Operational Amplifiers: Concept (Block diagram), properties, positive and negative feedback, loop gain, open loop gain, feedback factors; topologies of feedback amplifier; effect of feedback on gain, output impedance, input impedance, sensitivities (qualitative), bandwidth stability; effect of positive feedback: instability and oscillation, condition of oscillation, Barkhausen criteria. Introduction to integrated circuits.

TEXT BOOKS:

- Millman & Halkias: Integrated Electronics.
- Sedra & Smith: Microelectronics Engineering.

References:

- Malvino: Electronic Principle.
- Schilling & Belove: Electronics Circuits.
- Millman & Grabal: Microelectronics.
- Salivahanan: Electronics Devices & Circuits.
- Boyelstad & Nashelsky: Electronic Devices & Circuit Theory.

# JIS College of Engineering

(An Autonomous Institution)

Department of Computer Science and Engineering

Full Curriculum and Syllabus of B.Tech. in Computer Science and Engineering

Programme under Autonomous Framework

1<sup>st</sup> to 8<sup>th</sup> Semester. September 2015 reprint following 5<sup>th</sup> BOS meeting dated 24.09.2015

**Paper Name: Basic Electrical Engineering**

**Code: EE 201**

**Contacts: 3L**

**Credits: 3**

**Allotted hours: 42L**

**DC Network Theorem:** Definition of electric circuit, network, linear circuit, non-linear circuit, bilateral circuit, unilateral circuit, Dependent source, Kirchhoff's law, Principle of superposition. Source equivalence and conversion, Thevenin's theorem, Norton Theorem, nodal analysis, mesh analysis, star-delta conversion. Maximum power transfer theorem with proof. 7L

**Electromagnetism:** Biot-savart law, Ampere's circuital law, field calculation using Biot-savart & ampere's circuital law. Magnetic circuits, Analogous quantities in magnetic and electric circuits, Faraday's law, Self and mutual inductance. Energy stored in a magnetic field, B-H curve, Hysteretic and Eddy current losses, Lifting power of Electromagnet. 5L

**AC fundamental:** Production of alternating voltage, waveforms, average and RMS values, peak factor, form factor, phase and phase difference, phasor representation of alternating quantities, phasor diagram, behaviour of AC series, parallel and series parallel circuits, Power factor, Power in AC circuit, Effect of frequency variation in RLC series and parallel circuits, Resonance in RLC series and parallel circuit, Q factor, band width of resonant circuit. 6L

**Electrostatics:** Coulomb's law, Electric Field Intensity, Electric field due to a group of charges, continuous charge distribution, Electric flux, Flux density, Electric potential, potential difference, Gauss's law, proof of gauss's law, its applications to electric field and potential calculation, Capacitor, capacitance of parallel plate capacitor, spherical capacitor, isolated spheres, concentric conductors, parallel conductors. Energy stored in a capacitor. 5L

**DC Machines:** Construction, Basic concepts of winding (Lap and wave). DC generator: Principle of operation, EMF equation, characteristics (open circuit, load) DC motors: Principle of operation, Speed-torque Characteristics (shunt and series machine), starting (by 3 point starter), speed control (armature-voltage and field control) 6L

**Single phase transformer:** Core and shell type construction, EMF equation, no load and on load operation, phasor diagram and equivalent circuit, losses of a transformer, open and short circuit tests, regulation and efficiency calculation. 4L

**3 phase induction motor:** Types, Construction, production of rotating field, principle of operation, equivalent circuit and phasor diagram, rating, torque-speed characteristics (qualitative only). Starter for squirrel cage and wound rotor induction motor. Brief introduction of speed control of 3 phase induction motor (voltage control, frequency control, resistance control) 5L

**Three phase system:** Voltages of three balanced phase system, delta and star connection, relationship between line and phase quantities, phasor diagrams. Power measurement by two watt meters method. 3L

**General structure of electrical power system:** Power generation to distribution through overhead lines and under-ground cables with single line diagram. 1L

**Text books:**

1. Basic Electrical engineering, D.P Kothari & I.J Nagrath, TMH, Second Edition
2. Fundamental of electrical Engineering, Rajendra Prasad, PHI, Edition 2005.
3. Basic Electrical Engineering, V.N Mittle & Arvind Mittal, TMH, Second Edition
4. Basic Electrical Engineering, J.P. Tewari, New age international publication

**Reference books:**

1. Basic Electrical Engineering (TMH WBUT Series), Abhijit Chakrabarti & Sudipta Nath, TMH
2. Electrical Engineering Fundamental, Vincent.D.Toro, Pearson Education, Second Edition.
2. Hughes Electrical & Electronics Technology, 8/e, Hughes, Pearson Education.
3. Basic Electrical Engineering, T.K. Nagsarkar & M.S. Sukhija, Oxford
4. Introduction to Electrical Engineering, M.S. Naidu & S, Kamakshaiah, TMH
5. Basic Electrical Engineering, J.J. Cathey & S.A Nasar, TMH, Second Edition.

# JIS College of Engineering

(An Autonomous Institution)

Department of Computer Science and Engineering

Full Curriculum and Syllabus of B.Tech. in Computer Science and Engineering

Programme under Autonomous Framework

1<sup>st</sup> to 8<sup>th</sup> Semester. September 2015 reprint following 5<sup>th</sup> BOS meeting dated 24.09.2015

**Paper Name: Engineering Chemistry**

**Code: CH 201**

**Contacts: 3L**

**Credits: 3**

**Allotted hours: 40L**

## **Module 1**

Chemical Thermodynamics -I

Concept of Thermodynamic system: Definition with example of diathermal wall, adiabatic wall, isolated system, closed system, open system, extensive property, intensive property.

Introduction to first law of thermodynamics: different statements, mathematical form.

Internal energy: Definition, Example, Characteristics, Physical significance, Mathematical expression for change in internal Energy, Expression for change in internal energy for ideal gas.

Enthalpy: Definition, Characteristics, Physical significance, Mathematical expression for change in Enthalpy, Expression for change in enthalpy for ideal gas. 3L

Heat Capacity: Definition, Classification of Heat Capacity (Cp and CV): Definition and General expression of Cp - CV. Expression of Cp - CV for ideal gas.

Reversible and Irreversible processes: Definition, Work done in Isothermal Reversible and Isothermal Irreversible process for Ideal gas,

Adiabatic changes: Work done in adiabatic process, Interrelation between thermodynamic parameters (P, V and T), slope of P-V curve in adiabatic and isothermal process.

Application of first law of thermodynamics to chemical processes: exothermic, endothermic processes, law of Lavoisier and Laplace, Hess's law of constant heat summation, Kirchoff's law. 3L

2nd law of thermodynamics: Statement, Mathematical form of 2nd law of thermodynamics (Carnot cycle). Joule Thomson and throttling processes; Joule Thomson coefficient for Ideal gas, Concept of inversion temperature. 2L

Evaluation of entropy: characteristics and expression, entropy change in irreversible cyclic process, entropy change for irreversible isothermal expansion of an ideal gas, entropy change of a mixture of gases. 2L

Work function and free energy: Definition, characteristics, physical significance, mathematical expression of  $\Delta A$  and  $\Delta G$  for ideal gas, Maxwell's Expression (only the derivation of 4 different forms), Gibbs Helmholtz equation. Condition of spontaneity and equilibrium reaction. 2L

Electrochemistry

Conductance Conductance of electrolytic solutions, specific conductance, equivalent conductance, molar conductance and ion conductance, effect of temperature and concentration (Strong and Weak electrolyte).

Kohlrausch's law of independent migration of ions, transport numbers and hydration of ions. Conductometric titrations: SA vs SB & SA vs WB; precipitation titration KCl vs AgNO<sub>3</sub>. 2L

Electrochemical cell

Cell EMF and its Thermodynamic derivation of the EMF of a Galvanic cell (Nernst equation), single electrode potentials, hydrogen half cell, quinhydrone half cell and calomel half cell, Glass electrode (construction, representation, cell reaction, expression of potential, Discussion, Application)

Storage cell, fuel cell (construction, representation, cell reaction, expression of potential, Discussion, Application). 5L

## **Module 3**

Chemical bonding and states of matter Hydrogen bond, metallic bond and their applications. 2L

Solid state Chemistry Introduction to stoichiometric defects (Schottky & Frenkel) and non - stoichiometric defects (Metal excess and metal deficiency).

Conduction in Metal, Semiconductor-n type and p type, Effect of temperature on conductivity , p-n junction, rectifiers, transistors.

Photovoltaic cell, Fabrication of integrated circuits.

Role of silicon and germanium in the field of semiconductor. 4L

## **Module 4**

Introduction, classification, Hydrocarbon Molecules, Thermoplastic, Thermosetting Polymers. Basic Concepts Molecular Weight, Polymer Crystallinity. Crystallization, Melting and glass transition phenomena, Polymerization: addition, condensation, Copolymerization, Degree of polymerization, PDI. 3L

Electronic polymers-synthesis, properties, application. 2L

Preparation, properties, engineering applications of: polyethylene, PVC, Bakelite, nylon, natural rubber, vulcanization. elastomers - Buna-s, 2L

# JIS College of Engineering

(An Autonomous Institution)

Department of Computer Science and Engineering

Full Curriculum and Syllabus of B.Tech. in Computer Science and Engineering

Programme under Autonomous Framework

*1<sup>st</sup> to 8<sup>th</sup> Semester. September 2015 reprint following 5<sup>th</sup> BOS meeting dated 24.09.2015*

Introduction to Nanomaterials- Basic principle of nanoscience & technology, creation and use of bucky balls, structure, properties and uses of Carbon nanotubes, Applications of nanotechnology 3L

## Module 5

Industrial Chemistry

Solid Fuel: Coal, Classification of coal, constituents of coal, carbonization of coal (HTC and LTC), Coal analysis: Proximate and ultimate analysis.

Liquid fuel: Petroleum, classification of petroleum, Refining, Petroleum distillation, Thermal cracking, Octane number, Cetane number, Aviation Fuel (Aviation Gasoline, Jet Gasoline), Bio-diesel.

Gaseous fuels: Natural gas, water gas, Coal gas, bio gas. 5L

Reference Books:

Sashi Chawla, A Text Book of Engineering Chemistry, Dhanpat Rai & Co.Pvt. Ltd.

Engineering Chemistry, P. C. Jain, Dhanpat Rai Publication

P. C. Rakshit, Physical Chemistry, Sarat Book House (7th Edition).

P. Ghosh, Polymer Science and Technology of Plastics and Rubbers, Tata McGraw Hill Publishing Company Limited.

F.W.Billmeyer : Textbook of Polymer Science is published by Wiley India ( is now an Indian Imprint.)

Joel R. Fried, Polymer Science and Technology, Pearson Education (2nd Edition).

I. L. Finar, Organic Chemistry, Addison Wesley Longman, Inc.

Physical Chemistry, Atkins, 6th Edition, Oxford Publishers.

Organic Chemistry, Mark Loudon, 4th Edition, Oxford Publishers.

Concise Inorganic Chemistry, J. D. Lee, Black Well Science

**Paper Name: Chemistry Lab**

**Code: CH 291**

**Contacts: 3P**

**Credits: 2**

1. To Determine the alkalinity in a given water sample.
2. Red-ox titration (estimation of iron using permanganometry)
3. To determine calcium and magnesium hardness of a given water sample separately.
4. To determine the value of the rate constant for the hydrolysis of ethyl acetate catalyzed by hydrochloric acid.
5. Heterogeneous equilibrium (determination of partition coefficient of acetic acid between n-butanol and water)
6. Viscosity of solutions (determination of percentage composition of sugar solution from viscosity)
7. Conductometric titration for determination of the strength of a given HCl solution by titration against a standard NaOH solution.
8. pH- metric titration for determination of strength of a given HCl solution against a standard NaOH solution.
9. Determination of dissolved oxygen present in a given water sample.
10. To determine chloride ion in a given water sample by Argentometric method (using chromate indicator solution)

At least Six experiments must perform in a semester out of above Ten experiments.

# JIS College of Engineering

(An Autonomous Institution)

Department of Computer Science and Engineering

Full Curriculum and Syllabus of B.Tech. in Computer Science and Engineering

Programme under Autonomous Framework

*1<sup>st</sup> to 8<sup>th</sup> Semester. September 2015 reprint following 5<sup>th</sup> BOS meeting dated 24.09.2015*

**Paper Name: Programming in C Lab**

**Code: CS 291**

**Contacts: 3P**

**Credits: 2**

**Exercises should include but not limited to:**

1. Programs on Basic Computations.
2. Simple Programs: simple and compound interest calculations
3. Programs on number testing (Prime, even and odd, Palindrome, series, factorials, roots of a quadratic equation, Pascal's triangle etc.)
4. Programs based on different types of conditions.
5. Programs based on different types of loops.
6. Programs to demonstrate control structure: text processing, use of break and continue, etc.
7. Programs involving functions and recursion.
8. Programs involving the use of 1D and 2D arrays with subscripts and pointers.
9. Programs using structures and files.

**Paper Name: Basic Electronics Lab**

**Code: EC 291**

**Contacts: 3P**

**Credits: 2**

1. Familiarisation with passive and active electronic components such as Resistors, Inductors, Capacitors, Diodes, Transistors (BJT, FET) and electronic equipment like DC power supplies, multimeters etc.
2. Familiarisation with measuring and testing equipment like CRO, Signal generators etc.
3. Study of I-V characteristics of Junction diodes.
4. Study of I-V characteristics of Zener diodes.
5. Study of Half and Full wave rectifiers with Regulation and Ripple factors.
6. Study of I-V characteristics of BJTs (CE, CB).
7. Study of I-V characteristics of FETs (CS, CD).



# JIS College of Engineering

(An Autonomous Institution)

Department of Computer Science and Engineering

Full Curriculum and Syllabus of B.Tech. in Computer Science and Engineering

Programme under Autonomous Framework

*1<sup>st</sup> to 8<sup>th</sup> Semester. September 2015 reprint following 5<sup>th</sup> BOS meeting dated 24.09.2015*

**Paper Name: Basic Electrical Lab**

**Code: EE 291**

**Contacts: 3P**

**Credits: 2**

List of Experiments:

1. Characteristics of Fluorescent Lamp.
2. Characteristics of Tungsten Filament Lamp.
3. Verification of Thevenin's Theorem.
4. Verification of Norton's Theorem.
5. Verification of Superposition Theorem.
6. Study of R-L-C Series and Parallel Circuit.
7. Measurement of Power of a Three phase circuit by Two-wattmeter method.
8. Open Circuit test and short Circuit test of Single phase Transformer.
9. Speed Control of DC Motor.

**Paper Name: Presentation Design Lab**

**Code: CS 292**

**Contacts: 3P**

**Credits: 2**

1. Prepare presentation in Microsoft power point.

## **2. Introduction to HTML**

- The World Wide Web (WWW) and history of HTML
- Hypertext and Hypertext Markup Language
- Why HTML

### **HTML Documents**

1. Dividing the document into 2 parts.
  - ✓ Headers tags
  - ✓ Body tags
2. Paragraphs
3. Formattings
4. Elements of an HTML Document
6. Image tags
7. HTML Table tags
8. Lists

# JIS College of Engineering

(An Autonomous Institution)

Department of Computer Science and Engineering

Full Curriculum and Syllabus of B.Tech. in Computer Science and Engineering

Programme under Autonomous Framework

1<sup>st</sup> to 8<sup>th</sup> Semester. September 2015 reprint following 5<sup>th</sup> BOS meeting dated 24.09.2015

## 3<sup>rd</sup> Semester

<b>A. Theory</b>							
Sl. No.	Paper Code	Paper Name	Contact hours/week			Credit points	
			L	T	P		Total
1	CS 301	Data Structure & Algorithms	3	1	0	4	4
2	CS 302	Digital Logic	3	1	0	4	4
3	PH 301	Physics –II	3	0	0	3	3
4	M(CSE)301	Engineering Mathematics III	3	0	0	3	3
5	EE 301	Circuit Theory & Network Analysis	3	0	0	3	3
		<b>Total of Theory</b>				<b>17</b>	<b>17</b>
<b>B. Practical</b>							
Sl. No.	Paper Code	Paper Name	Contact hours/week			Credit points	
			L	T	P		Total
1	CS 391	Data Structure & Algorithm Lab	0	0	3	3	2
2	CS 392	Digital Logic Lab	0	0	3	3	2
3	PH 391	Physics –II Lab	0	0	3	3	2
4	CS 381	Innovative Mini Project-I	0	0	3	3	2
		<b>Total of Practical</b>				<b>12</b>	<b>8</b>
		<b>Total of Semester</b>				<b>29</b>	<b>25</b>

# JIS College of Engineering

(An Autonomous Institution)

Department of Computer Science and Engineering

Full Curriculum and Syllabus of B.Tech. in Computer Science and Engineering

Programme under Autonomous Framework

1<sup>st</sup> to 8<sup>th</sup> Semester. September 2015 reprint following 5<sup>th</sup> BOS meeting dated 24.09.2015

## 3<sup>rd</sup> Semester

**Paper Name: Data Structure & Algorithms**

**Code: CS 301**

**Contacts: 3L +1T**

**Credits: 4**

**Allotted hours: 42L**

### **Module- I: Introduction to Data Structure**

**[3L]**

Concepts of data structures: Data and data structure, Abstract Data Type. Algorithms and programs, basic idea of pseudo-code. Analysis of algorithms based on time and space complexity. Structure: Structure using pointer, array of structure.

### **Module- II: Linear Data Structure**

**[ 15L]**

Stack and Queue:

Stack and its implementations (using array), applications.

Implementation of queue-both linear and circular (using array), applications, queue implementation by using stack, dequeue. [7L]

Linked List :

Singly linked list, circular linked list, doubly linked list and applications. Implementation of Stack & Queue using Linked List. [6L]

Recursion :

Principles of recursion – use of stack, differences between recursion and iteration, tail recursion, head recursion. Application - The Tower of Hanoi Problem. [2L]

### **Module- III: Nonlinear Data structures**

**[13L]**

Trees:

Basic terminologies, tree representation (using array, using linked list).

Binary trees - binary tree traversal (pre, in, post order), threaded binary tree, expression tree.

Binary search tree- operations (creation, insertion, deletion, searching).

AVL tree (create, insertion, deletion with examples only).

B-Trees – operations (create, insertion, deletion with examples only). Basic overview of B\*-Tree and B<sup>+</sup>-Tree. [9L]

Graphs:

Graph definitions and concepts (directed/undirected) graph, weighted/un-weighted edges, complete graph, connected components – strongly connected component, weakly connected component, path, shortest path).

Graph representations/storage implementations – adjacency matrix, adjacency list, adjacency multi-list. [4L]

### **Module- IV: Searching, Sorting**

**[11L]**

Searching: Sequential search, Binary search, Interpolation Search [2L]

Sorting Algorithms: Bubble sort, insertion sort, shell sort, selection sort, merge sort, quick sort, heap sort (concept of max heap, application –priority queue), radix sort. [7L]

Hashing: Hashing functions, collision resolution techniques. [2L]

### **Recommended reference Books:**

Fundamentals of Data Structures in C, Ellis Horowitz, Sartaj Sahni, Susan Anderson-freed, Silicon Press

Data Structures Using C, Reema Thareja, Oxford University Press India

Data Structure Using C, 2/e, A.K. Rath, A. K. Jagadev, Scitech Publications

Data Structure Using C,2/e, A.K.Sharma Pearson Education, India

Data Structures in C, Aaron M. Tenenbaum, Prentice Hall.

Data Structures, S. Lipschutz, Tata McGraw Hill

# JIS College of Engineering

(An Autonomous Institution)

Department of Computer Science and Engineering

Full Curriculum and Syllabus of B.Tech. in Computer Science and Engineering

Programme under Autonomous Framework

1<sup>st</sup> to 8<sup>th</sup> Semester. September 2015 reprint following 5<sup>th</sup> BOS meeting dated 24.09.2015

**Paper Name: Digital Logic**

**Code: CS 302**

**Contacts: 3L +1T**

**Credits: 4**

**Allotted hours: 41L**

*Pre-requisite of Digital Electronics:* Binary numbers & Basic Boolean algebra – already covered in First year; Logic gates, Truth Tables and function realization – already covered in First year upto minimization of Logic expressions by algebraic method, K-map.

Module – 1: [12 L]

a) Binary Number System & Boolean Algebra (recapitulation ) [1L]; BCD, ASCII, EBDIC, Gray codes and their conversions [1L]; Signed binary number representation with 1's and 2's complement methods [1L], Binary arithmetic, Venn diagram, Boolean algebra (recapitulation) [2L]; Representation in SOP and POS forms [1L]; Minimization of logic expressions by algebraic method. [2L] (8L)

b) Combinational circuits - Adder and Subtractor circuits (half & full adder & subtractor) [2L]; Encoder, Decoder, Comparator, Multiplexer, De-Multiplexer and Parity Generator [2L]. (4L)

Module - 2: [11L]

1. Sequential Circuits - Basic Flip-flop & Latch [1L], Flip-flops -SR, JK, D, T and JK Master-slave Flip Flops[3L], (4L)

2. Registers (SISO, SIPO, PIPO, PISO) [2L], Ring counter, Johnson counter [1L], Basic concept of Synchronous and Asynchronous counters (detail design of circuits excluded), [2L], Design of Mod N Counter [2L] (7L)

Module-3[6L]

Asynchronous Sequential circuits- Fundamental mode Asynchronous Sequential circuits [1L], pulse mode Asynchronous Sequential circuits [1L], problems in Asynchronous circuits [2L], Design of hazard free switching circuits.[2L]

Module -4[6L]

Programmable Logic Devices- Programmable logic array [1L], Generic array logic devices [1L], classification of PLDs, CPLD, FPGA, ASICs. [4L]

Module – 5: [6L]

1. A/D and D/A conversion techniques – Basic concepts (D/A :R-2-R only [2L]

A/D: successive approximation [2L]) (4L)

2. Logic families- TTL, ECL, MOS and CMOS - basic concepts. (2L)

Textbooks:

Digital Electronics – Kharate – Oxford

Digital Electronics – Logic & Systems by J.Bigmeil & R.Donovan; Cambridge Learning.

Digital Logic and State Machine Design (3rd Edition) – D.J.Comer, OUP

Reference:

P.Raja- Digital Electronics- Scitech Publications

Morris Mano- Digital Logic Design- PHI

R.P.Jain—Modern Digital Electronics, 2/e , Mc Graw Hill

H.Taub & D.Shilling, Digital Integrated Electronics- Mc Graw Hill.

D.Ray Chaudhuri- Digital Circuits-Vol-I & II, 2/e- Platinum Publishers

Tocci, Widmer, Moss- Digital Systems,9/e- Pearson

J.Bignell & R.Donovan-Digital Electronics-5/e- Cenage Learning.

Leach & Malvino—Digital Principles & Application, 5/e, Mc Graw Hill

Floyd & Jain- Digital Fundamentals-Pearson.

# JIS College of Engineering

(An Autonomous Institution)

Department of Computer Science and Engineering

Full Curriculum and Syllabus of B.Tech. in Computer Science and Engineering

Programme under Autonomous Framework

1<sup>st</sup> to 8<sup>th</sup> Semester. September 2015 reprint following 5<sup>th</sup> BOS meeting dated 24.09.2015

**Paper Name: Physics -II**

**Code: PH 301**

**Contacts: 3L**

**Credits: 3**

**Allotted hours: 42L**

## **Module 1: Quantum Mechanics-II, Quantum Computation and Communication**

**1.01: Vector space & Heisenberg representation:** Elements of linear vector spaces- The idea of n- dimensional vector space, use of 'bra-ket' notation, linear independence, basis, inner product, norm of a vector; Hilbert space, Ortho normality; Matrix representation of bra & kets; linear operators; Pauli matrices; Definitions of Hermitian, Inverse and Unitary operators; Commutators; Tensor products. 5L

**1.02: Quantum Computation & Communication:** Idea of 'qubit' and examples of single qubit logic gates- Classical bits, Qubit as a two level system; Bloch vector representation of state of qubit; Polarization states of photon and measurements; Pauli gates, Phase shift gate, Quantum gates as rotations in Bloch sphere; concept of entanglement. Bell's inequality- the paradox, joint state of entangled particles; Two-qubit controlled gates; entanglement generation Quantum circuit for transforming computational basis to Bell basis; Quantum Teleportation (Basic idea) 6L

## **Module 2: PHYSICS OF SEMICONDUCTORS & ENERGY BAND THEORY**

**2.01: Applications of Schrödinger's equation** – Particle in one dimensional rigid box, Potential Barrier (emphasis on tunneling effect) 3L

**2.02: Free electron theory-** Free electron theory-Drude model, Ohm's law, Wideman Franz law, Electron scattering and resistance, relaxation time, diffusion length, mean free path. 2L

**2.03: Energy Band Theory:** Introduction to Band theory (mention qualitatively improvement over free electron theory)- Kronig-Penny model (Use Schrödinger picture to obtain Energy-band (E-k) diagram), formation of allowed and forbidden energy bands, Concept of effective mass – electrons and holes, crystal momentum, Density of states (qualitative), Energy bands of metal, insulator, semiconductor, magneto-resistance, magnetostriction, Piezoelectric effect, Hall effect, Hall coefficient. 4L

**2.04: Semiconductors and insulators:** Direct & indirect band gaps, Fermi-Dirac distribution function (temperature dependence-qualitative discussions). Fermi level for intrinsic and extrinsic semiconductors (dependence on temperature and doping concentration viz. p type, n-type, p-n, npn and pnp) ; Diffusion and drift current (qualitative). Generation and re-combination, quasi-Fermi energy level (basic concepts). 3L

## **Module 3: SOLID STATE ELECTRONIC & OPTO ELECTRONIC DEVICES**

**3.01: SOLID STATE ELECTRONICS DEVICES:** Classification of different types of diode on the basis of doping concentration: rectifier diode, Zener diode, tunnel diode, Gunn diode, IMPATT diode (importance of negative resistance), PNPN transistors - simple working principle, I-V characteristics, triggering, Triacs, Diacs & Thyristors, SCR-operating principle & application. 5L

**3.02: Field effect transistors:** MOS-capacitors, flat band and threshold voltages; basic principles of p and n channel MOSFETS, CMOS, NMOS and VLSI MOSFETS, Semiconductor sensors and detectors-applications. 3L

**3.03: OPTO ELECTRONIC DEVICES:** Basic background of photonic devices, Photoconductivity, Optical devices, Importance of reverse current in optical detectors, photo-diodes, photo voltaic effects (solar cells), Light Emitting Diode (as direct band gap material), avalanche and photodiode, Photo-transistors (Basic idea & application).LDR-Operation and applications. 4L

## **Module 4: Magnetism, Storage devices & Applications, Storage devices & applications:**

**4.01: Magnetism & Storage devices:** Magnetic field and Magnetization; Magnetic susceptibility, Paramagnetism, Concept of magnetic moment, Bohr Magneton, Curie's Law; Ferromagnetism, antiferromagnetism, and ferrimagnetism; Exchange interaction between magnetic ions (qualitative); Curie-Weiss law, concept of  $\theta_p$ , phenomenon of hysteresis, Hard ferromagnets, Comparison and applications of permanent magnets; Comparison and applications of Soft ferromagnets (Permalloys, Ferrites). Magnetic storage devices (examples related to computers) 4L

**4.02: Applications:** Magnetic ckt-Rawland ring, electro magnet, permanent magnet, comparison with electrical ckt. Magnetic resonance, NMR and MRI (qualitative discussions related to applications). Liquid crystal display (LCD)-Introduction-various phases and applications. 3L

# JIS College of Engineering

(An Autonomous Institution)

Department of Computer Science and Engineering

Full Curriculum and Syllabus of B.Tech. in Computer Science and Engineering

Programme under Autonomous Framework

*1<sup>st</sup> to 8<sup>th</sup> Semester. September 2015 reprint following 5<sup>th</sup> BOS meeting dated 24.09.2015*

**Paper Name: Engineering Mathematics III**

**Code: M(CSE) 301**

**Contacts: 3L**

**Credits: 3**

**Allotted hours: 42L**

**Module I:** Introduction to Propositional Calculus: Propositions, Logical Connectives, Conjunction, Disjunction, Negation and their truth table. Conditional Connectives, Implication, Converse, Contrapositive, Inverse, Biconditional statements with truth table, Logical Equivalence, Tautology, Normal forms-CNF, DNF; Predicates and Logical Quantifications of propositions and related examples.

Order Relation and Lattices: POSET, Hasse Diagram, Minimal, Maximal, Greatest and Least elements in a POSET, Lattices and its properties, Principle of Duality, Distributive and Complemented Lattices. 10L

**Module II:** Introduction to Group theory, Subgroup, Cyclic group and related problems. Introduction to Ring and Field. Related problems.

10L

**Module III:** Counting Techniques: Permutations, Combinations, Binomial coefficients, Pigeon-hole Principle, Principles of inclusion and exclusions; Recurrence relations: Formulation/Modeling of different counting problems in terms of recurrence relations, Solution of linear recurrence relations with constant coefficients (up to second order) by (i) The iterative method (ii) Characteristic roots method (iii) Generating functions method.

Introduction to probability theory and related problems. Introduction to probability distribution function (Discrete): Binomial, Poisson and related problems.

12L

**Module IV:** Graph Coloring: Chromatic Numbers and its bounds, Independence and Clique Numbers, Perfect Graphs-Definition and examples, Chromatic polynomial and its determination, Applications of Graph Coloring. Matching: Definitions and Examples of Perfect Matching, Maximal and Maximum Matching, Hall's Marriage

Theorem (Statement only) and related problems.

8L

## Texts:

1. CL Liu and D P Mohapatra- Elements of Discrete Mathematics, Tata McGraw Hill.
2. Mott Joe L., Anbraham Kandal and Theodore P Baker- Discrete Mathematics for Coputer Scientist & Mathematicians, Prentice Hall of India Pvt. Ltd., New Delhi, 1999.
3. M. K. sen and B. C. Chakraborty- Introduction to Discrete Mathematics, Books and Allied (P) Ltd.
4. S.K.S. Rathore, H. Chaudhari- Discrete structure and Graph Theory.
5. Gary Chartrand and Ping Zhang – Introduction to Graph Theory, TMH

## References:

- 1.J.K. Sharma, Discrete Mathematics, Macmillan
2. Winfried Karl Grassmann and Jean-Paul Tremblay, Logic and Discrete Mathematics, PEARSON.
- 3.S. K. Chakraborty and B. K. Sarkar, Discrete Mathematics, OXFORD University Press.
- 4.Douglas B. West, Introduction to graph Theory, PHI

# JIS College of Engineering

(An Autonomous Institution)

Department of Computer Science and Engineering

Full Curriculum and Syllabus of B.Tech. in Computer Science and Engineering

Programme under Autonomous Framework

*1<sup>st</sup> to 8<sup>th</sup> Semester. September 2015 reprint following 5<sup>th</sup> BOS meeting dated 24.09.2015*

**Paper Name: Circuit Theory & Network Analysis**

**Code: EE 301**

**Contacts: 3L**

**Credits: 3**

**Allotted hours: 42L**

Resonant Circuits: Series and Parallel resonance , Impedance and Admittance Characteristics, Quality Factor, Half Power Points, Bandwidth , Phasor diagrams, Practical resonant and series circuits.

Mesh Current Network Analysis: Kirchoff's Voltage law, Formulation of mesh equations , Solution of mesh equations by Cramer's rule and matrix method , Solution of problems with DC and AC sources.

Node Voltage Network Analysis: Kirchoff's Current law, Formulation of Node equations and solutions , Solution of problems with DC and AC sources .

Network Theorems: Definition and Implication of Superposition Theorem , Thevenin's theorem, Norton's theorem , Reciprocity theorem, Compensation theorem , maximum Power Transfer theorem , Millman's theorem, Star delta transformations , Solutions and problems with DC and AC sources .

Graph of Network: Concept of Tree and Branch, tree link, junctions, Incident matrix, Tie set matrix, Determination of loop currents and node voltages.

Circuit transients: DC transients in R-L and R-C Circuits with and without initial charge, R-L-C Circuits, AC Transients in sinusoidal R-L, R-C and R-L-C Circuits, Solution of Problems.

Laplace transform: Concept of Complex frequency , transform of  $f(t)$  into  $F(s)$  , transform of step, exponential, over damped surge, critically damped surge, damped and un-damped sine functions, properties of Laplace transform , linearity, real differentiation, real integration, initial value theorem and final value theorem, inverse Laplace transform , application in circuit analysis, Partial fraction expansion, Heaviside's expansion theorem, Solution of problems. Laplace transform and Inverse Laplace transform.

Two Port Networks: Relationship of Two port network variables, short circuit admittance parameters, open circuit impedance parameters, transmission parameters, relationship between parameter sets.

# JIS College of Engineering

(An Autonomous Institution)

Department of Computer Science and Engineering

Full Curriculum and Syllabus of B.Tech. in Computer Science and Engineering

Programme under Autonomous Framework

*1<sup>st</sup> to 8<sup>th</sup> Semester. September 2015 reprint following 5<sup>th</sup> BOS meeting dated 24.09.2015*

## Lab

**Paper Name: Data Structure & Algorithm Lab**

**Code: CS 391**

**Contacts: 3P**

**Credits: 2**

**Array & Structure Overview [6P]**

Implementation of Array & Structure in C

**Linear Data Structure [15P]**

Implementation of Stack.

Evaluation of expressions on Multiple stacks.

Implementation of Linear Queue, Circular queue, Dequeue.

Implementation of Singly Linked List, Circular Linked List & Doubly Linked List.

Implementation of Stack, Queue using linked list.

**Non-Linear Data Structure [9P]**

Implementation of an expression tree. Produce its pre-order, in-order, and post-order traversals.

Implementation of binary search tree.

Implementation of AVL trees.

**Searching, Sorting, Hashing [12P]**

Implementation of hashing with open addressing.

Implementation of searching techniques (Linear Search, Binary Search, Interpolation Search)

Implementation of different Sorting techniques: Bubble sort, Insertion sort, Selection sort, Quick sort, Merge sort, Heap sort, Radix sort etc.

**Paper Name: Digital Logic Lab**

**Code: CS 392**

**Contacts: 3P**

**Credits: 2**

**DIGITAL: At least any five of the following**

1. Design a Full Adder using basic gates and verify its output / Design a Full Subtractor circuit using basic gates and verify its output.
2. Construction of simple Decoder & Multiplexer circuits using logic gates.
3. Realization of RS / JK / D flip flops using logic gates.
4. Design of Shift Register using J-K / D Flip Flop.
5. Realization of Synchronous Up/Down counters.
6. Design of MOD- N Counter
7. Study of DAC.



# JIS College of Engineering

(An Autonomous Institution)

Department of Computer Science and Engineering

Full Curriculum and Syllabus of B.Tech. in Computer Science and Engineering

Programme under Autonomous Framework

1<sup>st</sup> to 8<sup>th</sup> Semester. September 2015 reprint following 5<sup>th</sup> BOS meeting dated 24.09.2015

**Paper Name: Physics II Lab**

**Code: PH 391**

**Contacts: 3P**

**Credits: 2**

## **Experiments on PHYSICS OF SEMICONDUCTORS & ENERGY BAND THEORY**

1. Determination of band gap of a semiconductors/thermistor.
2. Determination of Hall co-efficient of a semiconductors.
3. Measurement of Magnetoresistance of a semiconductor.
4. Determination of velocity of ultrasonic wave using piezoelectric crystal & compressibility of the given liquid.

## **Experiments on SOLID STATE ELECTRONIC & OPTO ELECTRONIC DEVICES**

5. To study current-voltage characteristics, load response, areal characteristics and spectral response of photo voltaic solar cells & measurement of maximum workable power.
6. Study of I-V characteristics of a thyristor
7. Study of I-V characteristics of a LED.
8. Study of phototransistor.
9. Study of a temperature sensor characteristics.
10. Study of I-V characteristics of Tunnel diode.
11. Study of LDR characteristics.

## **Experiments on Magnetism & Storage devices**

12. Study of hysteresis curve of a ferromagnetic material using CRO.
13. Use of paramagnetic resonance and determination of lande-g factor using esr setup.
14. Measurement of Curie temperature of the given sample.
15. Study of dipolar magnetic field behavior.

## **List of recommended Books:**

### **Module 1: Quantum Mechanics-II, Quantum Computation and Communication**

1. Advanced Quantum Mechanics-J. J. Sakurai (TMH)
2. Quantum Mechanics-Schiff (Addison-Wesley)
3. Quantum Computation and Quantum Information(10th Anniversary Edition)-Nielsen & Chuang (Cambridge University Press)
4. The physics of quantum information-Dirk Bouwmeester, Artur K. Ekert, Anton Zeilinger (Springer)
5. Quantum Mechanics-Cohen Tanuje.
6. Advanced Quantum Mechanics-P.A.M. Dirac

### **Module 2: PHYSICS OF SEMICONDUCTORS & ENERGY BAND THEORY**

1. Introduction to Quantum Mechanics-S. N. Ghoshal (Calcutta Book House)
2. Quantum Mechanics-Bagde Singh (S. Chand Publishers)
3. Perspective of Quantum Mechanics-S. P. Kuilla (New Central Book Agency)
3. Solid state physics- S. O. Pillai
4. Introduction to solid state physics-Kittel (TMH)
5. Solid State Physics- Ali Omar (Pearson Education)
6. Integrated Electronics-Millman Halkias (TMH)
7. Solid State Physics-A. J. Dekker (Prentice-Hall India)

### **Module 3: SOLID STATE ELECTRONIC & OPTO ELECTRONIC DEVICES**

1. Solid state electronics-S. M. Zee & Sanjoy Banerjee
2. Optoelectronic devices-Pallab Bhattacharjee

### **Module 4: Storage devices & Applications**

- 1 Introduction to solid state physics-Kittel (TMH)
2. Solid State Physics- Ali Omar (Pearson Education)
3. Solid state physics- S. O. Pillai
4. Solid State Physics-A. J. Dekker (Prentice-Hall India)
5. Materials Science-Raghavan

\* How staff works website

# **JIS College of Engineering**

(An Autonomous Institution)

Department of Computer Science and Engineering

Full Curriculum and Syllabus of B.Tech. in Computer Science and Engineering

Programme under Autonomous Framework

*1<sup>st</sup> to 8<sup>th</sup> Semester. September 2015 reprint following 5<sup>th</sup> BOS meeting dated 24.09.2015*

**Paper Name: Innovative Mini Project**

**Code: CS 381**

**Contacts: 3P**

**Credits: 2**

1. Notification of Project and Domain Name
2. Group Submission
3. Supervisor Selection
4. Notification of Group List and Assigned Domain
5. Project Allocation
6. Project Evaluation by Execution
7. End Semester Examination through report and project presentation

# JIS College of Engineering

(An Autonomous Institution)

Department of Computer Science and Engineering

Full Curriculum and Syllabus of B.Tech. in Computer Science and Engineering

Programme under Autonomous Framework

1<sup>st</sup> to 8<sup>th</sup> Semester. September 2015 reprint following 5<sup>th</sup> BOS meeting dated 24.09.2015

## 4<sup>th</sup> Semester

A. Theory						
Sl. No.	Paper Code	Paper Name	Contact hours/week			Credit points
			L	T	P Total	
1	M(CS)401	Numerical Methods	3	0	0 3	3
2	CS 401	Computer Organisation	3	1	0 4	4
3	CS 402	Operation Research Method	3	0	0 3	3
4	EI 401	Microprocessors & Microcontrollers	3	1	0 4	4
5	EC 401	Communication Engg.	3	1	0 4	4
		<b>Total of Theory</b>			<b>18</b>	<b>18</b>
B. Practical						
Sl. No.	Paper Code	Paper Name	Contact hours/week			Credit points
			L	T	P Total	
1	EI 491	Microprocessor & Microcontroller Lab	0	0	3 3	2
2	EC 491	Communication Engg Lab	0	0	3 3	2
3	M(CS)491	Numerical Analysis Lab	0	0	3 3	2
4	CS 492	Operation Research Lab	0	0	3 3	2
		<b>Total of Practical</b>			<b>12</b>	<b>8</b>
		<b>Total of Semester</b>			<b>30</b>	<b>26</b>

# JIS College of Engineering

(An Autonomous Institution)

Department of Computer Science and Engineering

Full Curriculum and Syllabus of B.Tech. in Computer Science and Engineering

Programme under Autonomous Framework

1<sup>st</sup> to 8<sup>th</sup> Semester. September 2015 reprint following 5<sup>th</sup> BOS meeting dated 24.09.2015

## 4<sup>th</sup> Semester

**Paper Name: Numerical Methods**

**Code: M(CS) 401**

**Contacts: 3L**

**Credits: 3**

**Allotted hours: 34L + 10T**

<b>Module I</b>	<b>Approximation and Errors in computing</b>	3L+1T
Introduction, Significant digits, Inherent error, Rounding error, Truncation error, Absolute and relative error, Error propagation.		
<b>Module II</b>	<b>Roots of Non Linear Equations and solution of system of Linear Equations</b>	12L+3T
Bisection method, False position Method, Newton-Raphson Method, convergence of Bisection, Newton- Raphson's and False position methods, Gauss Elimination method by pivoting, Gauss – Jordan method, Gauss – Seidel method, and convergence of iteration methods.		
<b>Module III</b>	<b>Difference Operators &amp; Interpolation</b>	7L+2T
Forward and Backward difference operators and table, Interpolation with equidistant point, Lagrange Interpolation Polynomial, Newton Interpolating Polynomial using divided Difference Table.		
<b>Module IV</b>	<b>Numerical Differentiation and Integration</b>	7L+2T
Differentiation continuous functions, differentiation of tabulated functions, Higher order derivatives, Trapezoidal rule, Simpson's rule.		
<b>Module V</b>	<b>Numerical Solution of Ordinary and Partial Differential Equations</b>	5L+2T
Taylor series method, Euler and modified Euler method, Runge Kutta methods.		
<b>References:</b>		
1. Numerical Method: E. Balagurusamy ,Tata McGraw Hill Publication		
2. Dutta & Jana: Introductory Numerical Analysis.		
3. J.B.Scarborough: Numerical Mathematical Analysis.		
4. Jain, Iyengar , & Jain: Numerical Methods (Problems and Solution).		
5. C.Xavier: C Language and Numerical Methods.		
6. Applied Numerical Analysis: Curtis F. Gerald and Patrick O. Wheatley – Pearson Education Lt		
7. Introductory Methods of Numerical Analysis : S.S. Sastry, PHI learning Pvt Ltd.		
8. Numerical Methods for Scientific and Engineering computation : M.K Jain, S.R.K Iyengar and R.K Jain,New age International Publishers.		
9. Kandasamy, P., Thilagavathy, K. and Gunavathy, K., “Numerical Methods”, S.Chand Co. Ltd., New Delhi, 2003.		
10. Burden, R.L and Faires, T.D., “Numerical Analysis”, Seventh Edition, Thomson Asia Pvt. Ltd., Singapore, 2002.		

# JIS College of Engineering

(An Autonomous Institution)

Department of Computer Science and Engineering

Full Curriculum and Syllabus of B.Tech. in Computer Science and Engineering

Programme under Autonomous Framework

*1<sup>st</sup> to 8<sup>th</sup> Semester. September 2015 reprint following 5<sup>th</sup> BOS meeting dated 24.09.2015*

**Paper Name: Computer Organisation**

**Code: CS 401**

**Contacts: 3L +1T**

**Credits: 4**

**Allotted hours: 42L**

Introduction: Basic organization and function of a stored program computer, Functional components of a computer, Interconnection of components, Performance of a computer [2L].

Representation of Instructions: Machine instructions, Operands, Addressing

modes, Instruction formats, Instruction sets, Addressing modes, Instruction set architectures - CISC and

RISC architectures [6L].

Arithmetic: Commonly used number systems. Fixed and floating point representation of numbers. Overflow and underflow. Design of adders - ripple carry and carry look ahead principles.

Fixed point multiplication -Booth's algorithm. Fixed point division - Restoring and non-restoring algorithms [8L].

Processing Unit: Organization of a processor - Registers, ALU and Control unit, Data path in a CPU, Instruction cycle, Organization of a control unit - Operations of a control unit, Hardwired control unit, Microprogrammed control unit [9L].

Memory Subsystem: Memory organization, Static and dynamic memory, Memory hierarchy, Associative memory, Secondary memory, Cache memory unit - Concept of cache memory, Mapping methods, Memory management unit - Concept of virtual memory, Address translation [10L].

Input/Output Subsystem: I/O operations, Concepts of handshaking, Program controlled I/O, Interrupt controlled I/O, and DMA controlled I/O [5L].

Pipelining: Introduction to instruction pipelining, pipeline hazards [2L].

Text Book:

1. Mano, M.M., "Computer System Architecture", PHI.
2. Behrooz Parhami "Computer Architecture", Oxford University Press
3. Hayes J. P., "Computer Architecture & Organisation", McGraw Hill
4. Hamacher, "Computer Organisation", McGraw Hill,
5. Chaudhuri P. Pal, "Computer Organisation & Design", PHI,

# JIS College of Engineering

(An Autonomous Institution)

Department of Computer Science and Engineering

Full Curriculum and Syllabus of B.Tech. in Computer Science and Engineering

Programme under Autonomous Framework

1<sup>st</sup> to 8<sup>th</sup> Semester. September 2015 reprint following 5<sup>th</sup> BOS meeting dated 24.09.2015

**Paper Name: Operation Research Method**

**Code: CS 402**

**Contacts: 3L**

**Credits: 3**

**Allotted hours: 35L**

## Module I

**INTRODUCTION:** Linear programming, Definition, scope of Operations Research (O.R) approach and limitations of OR Models, Characteristics and phases of OR Mathematical formulation of LLP Problems. [4L]

**SOLUTION OF LINEAR PROGRAMMING PROBLEMS:** Solution of LPP: Using Simultaneous Equations and Graphical Method; Definitions: Feasible Solution, Basic and non-basic Variables, Basic Feasible Solution, Degenerate and Non-degenerate Solution, slack, surplus and artificial variable. Solution of LPP by Simplex Method:- Charnes' Big-M Method; Duality Theory. [7L]

**TRANSPORTATION PROBLEM:** Formulation of transportation model, Basic feasible solution using different methods, Optimality Methods, Unbalanced transportation problem, Degeneracy in transportation problems, Applications of Transportation problems. Assignment Problem: Formulation, unbalanced assignment problem, travelling salesman problem. [6L]

## Module II

### Network Analysis:

Shortest Path: Floyd Algorithm; Maximal Flow Problem (Ford-Fulkerson); PERT-CPM (Cost Analysis, Crashing, Resource Allocation excluded). [5L]

### Inventory Control:

Introduction to EOQ Models of Deterministic and Probabilistic; Safety Stock; Buffer Stock. [3L]

## Module III

### Game Theory:

Introduction; 2-Person Zero-sum Game; Saddle Point; Mini-Max and Maxi-Min Theorems (statement only) and problems; Games without Saddle Point; Graphical Method; Principle of Dominance. [5L]

### Queuing Theory:

Introduction; Basic Definitions and Notations; Axiomatic Derivation of the Arrival & Departure (Poisson Queue). Poisson Queue Models: (M/M/1): ( $\infty$  / FIFO) and (M/M/1: N / FIFO) and problems. [3L]

### Text Books:

1. A.M. Natarajan, P. Balasubramani and A. Tamilarasi - "Operations Research", Pearson
2. Kanti Swaroop — "Operations Research", Sultan Chand & Sons
3. H. A. Taha, "Operations Research", Pearson
4. Ghosh and Chakraborty, "Linear Programming and Theory of Games", Central Book Agency

### References:

1. P. M. Karak – "Linear Programming and Theory of Games", ABS Publishing House
  2. Rathindra P. Sen—"Operations Research: Algorithms and Applications", PHI
  3. R. Panneerselvam - "Operations Research", PHI
  4. M. V. Durga Prasad – "Operations Research", CENGAGE Learning
- J. K. Sharma - "Operations Research", Macmillan Publishing Company

# JIS College of Engineering

(An Autonomous Institution)

Department of Computer Science and Engineering

Full Curriculum and Syllabus of B.Tech. in Computer Science and Engineering

Programme under Autonomous Framework

*1<sup>st</sup> to 8<sup>th</sup> Semester. September 2015 reprint following 5<sup>th</sup> BOS meeting dated 24.09.2015*

**Paper Name: Microprocessors & Microcontrollers**

**Code: EI 401**

**Contacts: 3L +1T**

**Credits: 4**

**Allotted hours: 42L**

Introduction to Microprocessor and microcontrollers, their advantages and disadvantages. Architecture of 8085 Microprocessor. Address / Data Bus multiplexing and demultiplexing. Status and Control signal generation. Instruction set of 8085 Microprocessor. Classification of instructions, addressing modes, timing diagram of the instructions.

Assembly language programming: Addition, Multiplication, Block Transfer, Ascending order, Descending order, Finding largest & smallest number, Look-up table etc. Interrupts of 8085 processor: classification and programming. Serial and parallel data transfer – Basic concept of serial I/O, DMA, Asynchronous and synchronous serial transmission using SID and SOD pins of 8085 Microprocessor. 8051 architecture: 8051 micro controller hardware, input/output pins, ports, external memory, counters and timers, instruction set, addressing modes, serial data i/o, interrupts. Assembly language Programming using 8051

Moving data: External data moves, code memory read only data moves, PUSH and POP opcodes, data exchanges. Logical operations: Byte-level, bit-level, rotate and swap operations. Arithmetic operations: Flags, incrementing and decrementing, addition, subtraction, multiplication and division, decimal arithmetic. Jump and call instructions: Jump and call program range, jumps, calls and subroutines, interrupts and returns. The 8086

microprocessor: Architecture, Pin details, memory segmentation, addressing modes, Familiarization of basic Instructions, Interrupts. Assembly language programming: Addition, Multiplication, Block Transfer, Ascending order, Descending order, finding largest & smallest number etc. Peripheral IC chips: 8255, 8253 and 8251: Block Diagram, Pin Details, Modes of operation, control word (s) format. Peripheral IC chips interfacing.

#### TEXT BOOKS:

1. Microprocessor architecture, programming and application with 8085 – R. Gaonkar (Penram International) (strongly recommended)
2. The 8051 microcontroller - K. Ayala (Thomson)
3. Microprocessors & interfacing – D. V. Hall (Tata McGraw-hill)
4. Ray & Bhurchandi, Advanced Microprocessors & Peripherals, TMH
5. The 8051 microcontroller and Embedded systems - Mazidi, Mazidi and McKinley (PEARSON)
6. An Introduction to Microprocessor and Applications –Krishna Kant (Macmillan)

#### TEXT BOOKS:

Microprocessors and microcontrollers - N. Senthil Kumar, M. Saravanan and Jeevananthan (Oxford university press).

8086 Microprocessor –K Ayala (Cengage learning)

Microprocessors – The 8086/8088, 80186/80386/80486 and the Pentium family – N. B. Bahadure (PHI).

The 8051 microcontrollers – Uma Rao and Andhe Pallavi (PEARSON).

# JIS College of Engineering

(An Autonomous Institution)

Department of Computer Science and Engineering

Full Curriculum and Syllabus of B.Tech. in Computer Science and Engineering

Programme under Autonomous Framework

1<sup>st</sup> to 8<sup>th</sup> Semester. September 2015 reprint following 5<sup>th</sup> BOS meeting dated 24.09.2015

**Paper Name: Communication Engg.**

**Code: EC 401**

**Contacts: 3L +1T**

**Credits: 4**

**Allotted hours: 42L**

## Module 1

**Introduction to Analog Communication:** Elements of communication system - Transmitters, Transmission channels & receivers, Concept of modulation, its need.

**2L**

## Module:2

**Continuous Wave Linear Modulation:** a) Amplitude modulation: Time domain representation of AM signal, modulation index, frequency domain (spectral) representations, transmission bandwidth, Phasor diagram, power & efficiency calculations (single and multi tone message); b) Double side band suppressed carrier (DSBSC) modulation, Single side band suppressed carrier modulation (SSBSC): time and frequency domain expressions, bandwidth and transmission power. Basic concept of VSB, Spectra and band-width.

**10L**

**Angle Modulation:** Frequency Modulation (FM) and Phase Modulation (PM): Time and Frequency domain representations, total power calculation for a single tone message. Phasor diagram;

**4L**

## Module:3

Frequency Division Multiplexing, Time Division Multiplexing, (FDM) b) Stereo – AM and FM: Basic concepts with block diagrams. Super heterodyne principle.

**2L**

## Module:4 (6L)

Types of Digital Modulation, coherent and non-coherent Binary Modulation Techniques, basic digital carrier modulation techniques: ASK, FSK and PSK, Coherent Binary Phase Shift Keying (BPSK), geometrical representation of BPSK signal; error probability of BPSK, generation and detection of BPSK Signal, power spectrum of BPSK. Concept of M-ary Communication, M-ary phase shift keying, the average probability of symbol error for coherent M-ary PSK, power spectra of MPSK, Quadrature Phase Shift Keying (QPSK), error probability of QPSK signal, generation and detection of QPSK signals, power spectra of QPSK signals, Offset Quadrature Phase shift Queuing (OQPSK), Coherent Frequency Shift Keying (FSK), Binary FSK, error probability of BFSK signals, generation and detection of Coherent Binary FSK signals, power spectra of BFSK signal, Minimum Shift Keying (MSK), signal constellation of MSK waveforms, error probability of MSK signal

**12L**

## Text Books:

7. Taub and Schilling , “Principles of Communication Systems”, 2nd ed., Mc-Graw Hill
8. B.P.Lathi -Communication Systems- BS Publications
2. V Chandra Sekar – Analog Communication- Oxford University Press

## References:

9. Principles of Communication Systems, H. Taub and D.L.Schilling, TMH Publishing Co.
10. Carlson—Communication System,4/e , Mc-Graw Hill
11. Singh & Sapre—Communication Systems: 2/e, TMH
12. P K Ghosh- Principles of Electrical Communications- University Press
13. L.W.Couch II, “Digital and Analog Communication Systems”, 2/e, Macmillan Publishing
14. Blake, Electronic Communication Systems- Cengage Learning
15. S Sharma, Analog Communication Systems- Katson Books



# JIS College of Engineering

(An Autonomous Institution)

Department of Computer Science and Engineering

Full Curriculum and Syllabus of B.Tech. in Computer Science and Engineering

Programme under Autonomous Framework

*1<sup>st</sup> to 8<sup>th</sup> Semester. September 2015 reprint following 5<sup>th</sup> BOS meeting dated 24.09.2015*

## Lab

**Paper Name: Microprocessor & Microcontroller Lab**

**Code: EI 491**

**Contacts: 3P**

**Credits: 2**

1. Study of prewritten programs on trainer kit using the basic instruction set (data transfer, Load/Store, Arithmetic, Logical) Assignments based on above.
2. Familiarization with 8085 & 8051 simulator on PC. Study of prewritten programs using basic instruction set (data transfer, Load/Store, Arithmetic, Logical) on the simulator.
3. Assignments (any six) based on above a. Table look up  
b. Copying a block of memory  
c. Shifting a block of memory  
d. Packing and unpacking of BCD numbers e. Addition of BCD numbers  
f. Binary to ASCII conversion  
g. String Matching, Multiplication using shift and add method and Booth's Algorithm  
h. Program using subroutine calls and IN/OUT instructions using 8255 PPI on the trainer kit e.g. subroutine for delay, reading switch state and glowing LEDs accordingly.  
i. Interfacing of 8255  
j. Study of 8051 Micro controller kit and writing programs as mentioned above.  
Write programs to interface of Keyboard, DAC and ADC using the kit. k. Serial communication between two trainer kits

**Paper Name: Communication Engg Lab**

**Code: EC 491**

**Contacts: 3P**

**Credits: 2**

Program Objective:

To provide the basic skills required to understand, develop, and design various engineering applications involving analog communication theory. To provide basic laboratory exposure to communication principles and applications.

List of Experiments:

1. Measurement of modulation index of an AM signal.
2. measurement of output power with varying modulation index an AM signal(for both DSB-& SSB).
3. Measurement of distortion of the demodulated output with varying modulation index of an AM signal (for both DSB-SC & SSB).
4. Measurement of power of different frequency components of a frequency modulated signal & the measurement of the bandwidth.
- 5..Design a FM demodulation
6. Measurement of selectivity, sensitivity, fidelity of a super heterodyne receiver.
7. Study of PAM and demodulation.
8. Study of PCM and demodulation.
9. Study of delta modulator and demodulator.
10. Study of adaptive delta modulator and demodulator.
11. Study of ASK modulator and demodulator.
12. Study of BPSK modulator and demodulator.
13. Study of BFSK modulator and demodulator.
14. Study of QPSK modulator and demodulator.

# JIS College of Engineering

(An Autonomous Institution)

Department of Computer Science and Engineering

Full Curriculum and Syllabus of B.Tech. in Computer Science and Engineering

Programme under Autonomous Framework

*1<sup>st</sup> to 8<sup>th</sup> Semester. September 2015 reprint following 5<sup>th</sup> BOS meeting dated 24.09.2015*

**Paper Name: Numerical Analysis Lab**

**Code: MCS 491**

**Contacts: 3P**

**Credits: 2**

1. Write a program to implement the Bisection Method.
2. Write a program to implement the Regular-falsi and Newton Raphson methods.
3. Write a program to implement the Gauss Elimination method.
4. Write a program to implement the Gauss-Seidel.
5. Write a program to implement the Gauss-Jordon method
6. Write a program to implement the Euler's method.
7. Write a program to implement the Runge-Kutta methods.
8. Write a program to implement the Trapezoidal rule
9. Write a program to implement the Simpson's 1/3 rule.
10. Write a program to implement Newton forward /backward interpolation
11. Write a program to implement Lagrange's interpolation.
12. Introduction to Software Packages: Matlab.

**Paper Name: Operation Research Lab**

**Code: CS 492**

**Contacts: 3P**

**Credits: 2**

Software based lab using C.

- 1) Linear Programming ( Transportation , Assignment , Duality , Simplex)
- 2) Shortest Path ( Dijkstra's , Floyd's Algorithm)
- 2) Maximal Flow.
- 3) PERT/CPM
- 4) Queueing Theory

N:B:-Familiarization with any O.R package.

# JIS College of Engineering

(An Autonomous Institution)

Department of Computer Science and Engineering

Full Curriculum and Syllabus of B.Tech. in Computer Science and Engineering

Programme under Autonomous Framework

1<sup>st</sup> to 8<sup>th</sup> Semester. September 2015 reprint following 5<sup>th</sup> BOS meeting dated 24.09.2015

## 5<sup>th</sup> Semester

<b>A. Theory</b>						
Sl. No.	Paper Code	Paper Name	Contact hours/week			Credit points
			L	T	P Total	
1	CS 501	Design & Analysis of Algorithm	3	1	0 4	4
2	CS 502	Operating System	3	1	0 4	4
3	CS 503	Computer Networks	3	1	0 4	4
4	CS 504	Computer Architecture	3	0	0 3	3
5	CS 505	Object Oriented Programming	3	0	0 3	3
		<b>Total of Theory</b>			<b>18</b>	<b>18</b>
<b>B. Practical</b>						
Sl. No.	Paper Code	Paper Name	Contact hours/week			Credit points
			L	T	P Total	
1	CS 591	Design & Analysis of Algorithm Lab	0	0	3 3	2
2	CS 592	Operating Systems Lab	0	0	3 3	2
3	CS 593	Computer Networks Lab	0	0	3 3	2
4	CS 595	Object Oriented Programming Lab	0	0	3 3	2
5	HU 591	Language Practice Lab	0	0	3 3	2
		<b>Total of Practical</b>			<b>15</b>	<b>10</b>
		<b>Total of Semester</b>			<b>33</b>	<b>28</b>

# JIS College of Engineering

(An Autonomous Institution)

Department of Computer Science and Engineering

Full Curriculum and Syllabus of B.Tech. in Computer Science and Engineering

Programme under Autonomous Framework

1<sup>st</sup> to 8<sup>th</sup> Semester. September 2015 reprint following 5<sup>th</sup> BOS meeting dated 24.09.2015

## 5<sup>th</sup> Semester

**Paper Name: Design & Analysis of Algorithm**

**Code: CS 501**

**Contacts: 3L + 1T**

**Credits: 4**

**Allotted hours: 42L**

### **Module 1: Complexity Analysis**

**[4L]**

Time and Space Complexity, Model of Computation-RAM, Turing Machine, Different Asymptotic notations – their mathematical significance. Recurrence relations: Solving recurrence relations. Master Theorem.

### **Module 2: Recursion**

**[2L]**

Iteration vs. Recursion, Tail Recursion, Application- Tower of Hanoi Problem & its complexity.

### **Module 3: Basic Introduction to Algorithmic Paradigm**

**[16L]**

Divide and Conquer: [3L]

Basic method, use, Examples – Binary Search, Merge Sort, Quick Sort and their complexity.

Heap Sort & its complexity [2L]

Dynamic Programming: [4L]

Basic method, use, Examples – Matrix Chain Manipulation, All pair shortest paths, Single source shortest path (Dijkstra, Bellman-Ford), Travelling salesman problem.

Backtracking: [3L]

Basic method, use, Examples – 8 queens problem, Graph Coloring problem, Hamiltonian Cycle problem.

Greedy Method: [4L]

Basic method, use, Examples – Fractional Knapsack problem, Job sequencing with deadlines, Minimum cost spanning tree by Prim's and Kruskal's algorithm.

### **Module 4: Disjoint set manipulation**

**[2L]**

Set manipulation algorithm like UNION-FIND, union by rank.

### **Module 5: Graph algorithm**

**[3L]**

Breadth First Search (BFS) and Depth First Search (DFS), Topological sort.

### **Module 6: String matching problem**

**[3L]**

Different techniques – Naive algorithm, String matching using finite automata, and Knuth, Morris, Pratt (KMP) algorithm with their complexities.

### **Module 7: Network Flow**

**[2L]**

Ford Fulkerson algorithm, Max-Flow Min-Cut theorem with illustration.

### **Module 8: Matrix Algorithm**

**[2L]**

Strassen's matrix multiplication algorithm; LU decomposition, Inverse computation

### **Module 9: Notion of NP-completeness**

**[4L]**

P class, NP class, NP hard class, NP complete class – their interrelationship, Satisfiability problem, Clique decision problem, Cook's Theorem.

### **Module 10: Approximation Algorithms**

**[4L]**

Necessity of approximation scheme, performance guarantee, polynomial time approximation schemes, vertex cover problem, travelling salesman problem.

**[Total-42L]**

### **Recommended reference Books:**

[1] T. H. Cormen, C. E. Leiserson, R. L. Rivest and C. Stein-“Introduction to Algorithms”

[2] A. Aho, J.Hopcroft and J.Ullman- “The Design and Analysis of Algorithms”

[3] E.Horowitz and Shahni- “Fundamentals of Computer Algorithm

# JIS College of Engineering

(An Autonomous Institution)

Department of Computer Science and Engineering

Full Curriculum and Syllabus of B.Tech. in Computer Science and Engineering

Programme under Autonomous Framework

1<sup>st</sup> to 8<sup>th</sup> Semester. September 2015 reprint following 5<sup>th</sup> BOS meeting dated 24.09.2015

**Paper Name: Operating System**

**Code: CS 502**

**Contacts: 3L + 1T**

**Credits: 4**

**Allotted hours: 42L**

## **Module 1: Basics**

**3L**

Operating System Functionalities, evolution of O.S., Different types of O.S.: batch, multi-programmed, time-sharing, real-time, distributed, parallel, Structural overview, Loader, linker, assembler, command interpreter, compiler

## **Module 2: Process Management**

**18L**

Processes: Concept of processes, process states, PCB, process scheduling, co-operating processes, independent process, suspended process, Interaction between processes and OS, Inter-process communication: Message passing, pipes.

**3L**

Threads: overview, benefits of threads, user and kernel level threads, threading models. 2L

CPU scheduling: scheduling criteria, preemptive & non-preemptive scheduling, scheduling algorithms (FCFS, SJF, SRTF, RR, priority, multilevel queue, multilevel feedback queue scheduling).

**4L**

Process Synchronization : background, critical section problem, synchronization hardware, classical problems of synchronization(producer-consumer, readers-writer, dining philosophers, etc), semaphores, monitors.

**5L**

Deadlocks: deadlock characterization, methods for handling deadlocks, deadlock prevention, deadlock avoidance, deadlock detection, recovery from deadlock.

**4L**

## **Module 3: Memory Management**

**7L**

Background, logical vs. physical address space, swapping, contiguous memory allocation, paging, Segmentation, TLB.

**4L**

Virtual Memory: background, demand paging, page replacement algorithms (FCFS, LRU, Optimal), thrashing, Working set model.

**3L**

## **Module 4: I/O Management**

**4L**

I/O hardware, polling, interrupts, DMA, caching, buffering, blocking-non blocking I/O.

## **Module 5: Disk Management**

**4L**

Disk structure, disk scheduling (FCFS, SSTF, SCAN,C-SCAN,LOOK,C-LOOK etc),disk reliability, disk formatting, boot block, bad blocks.

## **Module 6: File Systems**

**3L**

File concept, access methods, directory structure, file system structure, UNIX file structure, allocation methods (contiguous, linked, indexed), free-space management (bit vector).

## **Module 7: Protection & Security**

**3L**

Goals of protection, domain of protection, access rights, access matrix, security problem, authentication, one time password, threats( Virus, Worm, Trojan horse etc), encryption.

### **Recommended reference Books:**

[1]Abraham Silberschatz, Peter B. Galvin, Greg Gagne, Operating System Concepts. Sixth edition. Addison-Wesley (2003)

[2]Andrew Tanenbaum, Modern Operating Systems, Prentice Hall.

[3]William Stallings, Operating Systems, Prentice Hall.

[4] Dhamdhare, Operating System, TMH

# JIS College of Engineering

(An Autonomous Institution)

Department of Computer Science and Engineering

Full Curriculum and Syllabus of B.Tech. in Computer Science and Engineering

Programme under Autonomous Framework

*1<sup>st</sup> to 8<sup>th</sup> Semester. September 2015 reprint following 5<sup>th</sup> BOS meeting dated 24.09.2015*

**Paper Name: Computer Networks**

**Code: CS 503**

**Contacts: 3L + 1T**

**Credits: 4**

**Allotted hours: 42L**

**Module I [12L]**

Overview of data communication and Networking

Introduction; Data communications: components, data representation (ASCII, ISO etc.), Transmission modes (simplex, half duplex, full duplex); Networks: distributed processing, network criteria, physical structure (type of connection, topology), categories of network (LAN, MAN, WAN); Internet: brief history, internet today; Protocols and standards; Reference models: OSI reference model, TCP/IP reference model, their comparative study.

Physical level:

Overview of data (analog & digital), signal (analog & digital), transmission (analog & digital) & transmission media (guided & unguided); Different types of encoding, TDM, FDM, WDM; Circuit switching: time division & space division switch, TDM bus; Telephone network;

**Module II [10L]**

Data link layer:

Types of errors, framing (character and bit stuffing), error detection correction methods; Flow control; Protocols: Stop & wait ARQ, Go Back N ARQ, Selective repeat ARQ, HDLC.

Medium access sub layer: Point to point protocol, LCP, NCP, FDDI, token bus, token ring; Reservation, polling, concentration; Multiple access protocols: Pure ALOHA, Slotted ALOHA, CSMA, CSMA/CD, FDMA, TDMA, CDMA; Traditional Ethernet, fast Ethernet;

**Module III [12L]**

Network layer:

Internetworking & devices: Repeaters, Hubs, Bridges, Switches, Router, gateway; Addressing: Internet address, classful address, subnetting; Routing: techniques, static vs. dynamic routing, routing table for classful address, NAT; Routing algorithms: shortest path algorithm, flooding, distance vector routing, link state routing; Protocols: IPV4, ARP, RARP, BOOTP, DHCP, ICMP, IPV6; Unicast and multicast routing protocols.

Transport layer:

Process to process delivery; UDP; TCP; Congestion control: Open loop and Closed loop, Leaky bucket algorithm, Token bucket algorithm, choke packets; Quality of service: Techniques to improve Qos.

**Module IV [8L]**

Application layer:

DNS; Email, SMTP, SNMP, FTP, HTTP & WWW; Security: Cryptography, user authentication, security protocols in internet, Digital Signature, Firewalls.

Modern topics:

ISDN services & ATM; DSL technology, Cable modem, Wireless LAN: IEEE 802.11; Introduction to Bluetooth, VLAN's, Cellular telephony & Satellite network.

Text Books:

1. B. A. Forouzan – “Data Communications and Networking (3rd Ed.)” – TMH
2. A. S. Tanenbaum – “Computer Networks (4th Ed.)” – Pearson Education/PHI
3. W. Stallings – “Data and Computer Communications (5th Ed.)” – PHI/ Pearson Education
4. Zheng & Akhtar, Network for Computer Scientists & Engineers, OUP
5. Black, Data & Computer Communication, PHI
6. Miller, data Communication & Network, Vikas
7. Miller, Digital & Data Communication, Jaico
8. Shay, Understanding Data Communication & Network, Vikas

Reference Books:

1. Kurose and Rose – “Computer Networking -A top down approach featuring the internet” – Pearson Education
2. Leon, Garica, Widjaja – “Communication Networks” – TMH
3. Walrand – “Communication Networks” – TMH.
4. Comer – “Internetworking with TCP/IP, vol. 1, 2, 3(4th Ed.)” – Pearson Education/PHI

# JIS College of Engineering

(An Autonomous Institution)

Department of Computer Science and Engineering

Full Curriculum and Syllabus of B.Tech. in Computer Science and Engineering

Programme under Autonomous Framework

*1<sup>st</sup> to 8<sup>th</sup> Semester. September 2015 reprint following 5<sup>th</sup> BOS meeting dated 24.09.2015*

**Paper Name: Computer Architecture**

**Code: CS 504**

**Contacts: 3L**

**Credits: 3**

**Allotted hours: 38L**

Module – 1: [12 L]

Introduction: Review of basic computer architecture (Revisited), Quantitative techniques in computer design, measuring and reporting performance. (3L)

Pipelining: Basic concepts, instruction and arithmetic pipeline, data hazards, control hazards and structural hazards, techniques for handling hazards. Exception handling. Pipeline optimization techniques; Compiler techniques for improving performance. (9L)

Module – 2: [8L]

Hierarchical memory technology: Inclusion, Coherence and locality properties; Cache memory organizations, Techniques for reducing cache misses; Virtual memory organization, mapping and management techniques, memory replacement policies. (8L)

Module – 3: [6L]

Instruction-level parallelism: basic concepts, techniques for increasing ILP, superscalar, superpipelined and VLIW processor architectures. Array and vector processors. (6L)

Module – 4: [12 L]

Multiprocessor architecture: taxonomy of parallel architectures; Centralized shared- memory architecture: synchronization, memory consistency, interconnection networks. Distributed shared-memory architecture. Cluster computers. (8L)

Non von Neumann architectures: data flow computers, reduction computer architectures, systolic architectures. (4L)

Text books:

1. Hwang, K. “Advanced Computer architecture with parallel programming”, McGraw Hill, 1993
2. Carter—Computer Architecture ( Schaum Series),TMH
3. Patterson D.A. and Hennessy , J.L. “Computer architecture a quantitative approach”, 2nd ed., Morgan Kaufman, 1996
4. Hwang & Briggs—Computer Architecture & Parallel Processing, TMH
5. Stone, H.S., “Advanced Computer”, Addison Wesley, 1989
6. Siegel, H.J., “Interconnection Network for Large Scale parallel Processing”, 2nd Ed., McGraw Harchitectureill, 1990

# JIS College of Engineering

(An Autonomous Institution)

Department of Computer Science and Engineering

Full Curriculum and Syllabus of B.Tech. in Computer Science and Engineering

Programme under Autonomous Framework

*1<sup>st</sup> to 8<sup>th</sup> Semester. September 2015 reprint following 5<sup>th</sup> BOS meeting dated 24.09.2015*

**Paper Name: Object Oriented Programming**

**Code: CS 505**

**Contacts: 3L**

**Credits: 3**

**Allotted hours: 36L**

## **Object oriented design [10 L]**

Concepts of object oriented programming language, Major and minor elements, Object, Class, relationships among objects, aggregation, links, relationships among classes-association, aggregation, using, instantiation, meta-class, grouping constructs.

## **Object oriented concepts [4 L]**

Difference between OOP and other conventional programming – advantages and disadvantages. Class, object, message passing, inheritance, encapsulation, polymorphism

## **Basic concepts of object oriented programming using Java [22 L]**

Implementation of Object oriented concepts using Java.

### **Language features to be covered:**

#### **Class & Object proprieties [6L]**

Basic concepts of java programming – advantages of java, byte-code & JVM, data types, access specifiers, operators, control statements & loops, array, creation of class, object, constructor, finalize and garbage collection, use of method overloading, this keyword, use of objects as parameter & methods returning objects, call by value & call by reference, static variables & methods, garbage collection, nested & inner classes, basic string handling concepts- String (discuss charAt(), compareTo(), equals(), equalsIgnoreCase(), indexOf(), length(), substring(), toCharArray(), toLowerCase(), toString(), toUpperCase(), trim(), valueOf() methods) & StringBuffer classes (discuss append(), capacity(), charAt(), delete(), deleteCharAt(), ensureCapacity(), getChars(), indexOf(), insert(), length(), setCharAt(), setLength(), substring(), toString() methods), concept of mutable and immutable string, command line arguments, basics of I/O operations – keyboard input using BufferedReader & Scanner classes.

**Reusability properties[6L]** – Super class & subclasses including multilevel hierarchy, process of constructor calling in inheritance, use of super and final keywords with super() method, dynamic method dispatch, use of abstract classes & methods, interfaces. Creation of packages, importing packages, member access for packages.

**Exception handling & Multithreading [6L]** – Exception handling basics, different types of exception classes, use of try & catch with throw, throws & finally, creation of user defined exception classes. Basics of multithreading, main thread, thread life cycle, creation of multiple threads, thread priorities, thread synchronization, interthread communication, deadlocks for threads, suspending & resuming threads.

**Applet Programming (using swing) [4L]** – Basics of applet programming, applet life cycle, difference between application & applet programming, parameter passing in applets, concept of delegation event model and listener, I/O in applets, use of repaint(), getDocumentBase(), getCodeBase() methods, layout manager (basic concept), creation of buttons (JButton class only) & text fields.

Textbooks/References:

1. Rambaugh, James Michael, Blaha – "Object Oriented Modelling and Design" – Prentice Hall, India
2. Ali Bahrami – "Object Oriented System Development" – Mc Graw Hill
3. Patrick Naughton, Herbert Schildt – "The complete reference-Java2" – TMH
4. R.K Das – "Core Java For Beginners" – VIKAS PUBLISHING
5. Deitel and Deitel – "Java How to Program" – 6th Ed. – Pearson
6. Ivor Horton's Beginning Java 2 SDK – Wrox
7. E. Balagurusamy – " Programming With Java: A Primer" – 3rd Ed. – TMH



# JIS College of Engineering

(An Autonomous Institution)

Department of Computer Science and Engineering

Full Curriculum and Syllabus of B.Tech. in Computer Science and Engineering

Programme under Autonomous Framework

*1<sup>st</sup> to 8<sup>th</sup> Semester. September 2015 reprint following 5<sup>th</sup> BOS meeting dated 24.09.2015*

## Lab

**Paper Name: Design & Analysis of Algorithm Lab**

**Code: CS 591**

**Contacts: 3P**

**Credits: 2**

### 1. Recursion [3P]

Tower of Hanoi Problem.

Fibonacci Series implementation.

### 2: Divide and Conquer [9P]

Binary Search using Divide and Conquer approach

Merge Sort using Divide and Conquer approach

Quick Sort using Divide and Conquer approach

Heap Sort implementation.

### 3: Dynamic Programming [9P]

Minimum number of scalar multiplication needed for chain of matrix

All pair of Shortest path for a graph (Floyd- Warshall Algorithm)

Traveling Salesman Problem

Single Source shortest Path for a graph (Dijkstra, Bellman Ford Algorithm)

### 4: Backtracking [6P]

8 Queen's problem

Graph Coloring Problem

### 5: Greedy method [6P]

Fractional Knapsack Problem

Job sequencing with deadlines

Minimum Cost Spanning Tree by Prim's Algorithm

Minimum Cost Spanning Tree by Kruskal's Algorithm

### 6: Graph Traversal Algorithm [6P]

Breadth First Search (BFS)

Depth First Search (DFS)

### 7: String Matching Problem [6P]

Naive String Matching

KMP Algorithm implementation

# JIS College of Engineering

(An Autonomous Institution)

Department of Computer Science and Engineering

Full Curriculum and Syllabus of B.Tech. in Computer Science and Engineering

Programme under Autonomous Framework

*1<sup>st</sup> to 8<sup>th</sup> Semester. September 2015 reprint following 5<sup>th</sup> BOS meeting dated 24.09.2015*

**Paper Name: Operating Systems Lab**

**Code: CS 592**

**Contacts: 3P**

**Credits: 2**

1. **Essential Linux Commands[6P]:** Commands for files and directories cd, cp, mv, rm, mkdir, more, less, creating and viewing files, using cat, file comparisons, View files, kill, ps, who, sleep, grep, fgrep, find, sort, cal, banner, touch, file related commands – ws, sat, cut, grep etc. Mathematical commands –expr, factor, units.
2. **Shell Programming [6P]:** Creating a script, making a script executable, shell syntax (variables, conditions, control structures, functions, and commands).
3. **Process [3P]:** Starting new process, replacing a process image, duplicating a process image.
4. **CPU Scheduling Algorithm [6P]:** Implementation of FCFS, SJF, SRTF, Priority scheduling, RR Scheduling algorithms & calculation of waiting time, turn-around time.
5. **Signal[3P]:** Signal handling, sending signals etc
6. **Semaphore [3P]:** Programming with semaphores (use functions semget, semop, semaphore\_p, semaphore\_v).
7. **POSIX Threads[6P]:** Programming with pthread functions(viz. pthread\_create, pthread\_join, pthread\_exit, pthread\_attr\_init, pthread\_cancel)
8. **Memory Management [3P]:** Implementation of First Fit, Best Fit, Worst Fit storage allocation algorithms.
9. **Inter-Process Communication [3P]:** Pipes(use functions pipe, popen, pclose), named Pipes (FIFOs, accessing FIFO)

# JIS College of Engineering

(An Autonomous Institution)

Department of Computer Science and Engineering

Full Curriculum and Syllabus of B.Tech. in Computer Science and Engineering

Programme under Autonomous Framework

*1<sup>st</sup> to 8<sup>th</sup> Semester. September 2015 reprint following 5<sup>th</sup> BOS meeting dated 24.09.2015*

**Paper Name: Computer Networks Lab**

**Code: CS 593**

**Contacts: 3P**

**Credits: 2**

IPC (Message queue)

NIC Installation & Configuration (Windows/Linux)

Familiarization with Networking cables (CAT5, UTP, and Fiber Optics)

Connectors (RJ45, T-connector) Hubs, Switches

TCP/UDP Socket Programming

Multicast & Broadcast Sockets

Implementation of Data Link Layer Flow Control Mechanism (Stop & Wait, Sliding Window)

Data Link Layer Error Detection Mechanism (Cyclic Redundancy Check)

Data Link Layer Error Control Mechanism (Selective Repeat, Go Back N)

**Paper Name: Object Oriented Programming Lab**

**Code: CS 595**

**Contacts: 3P**

**Credits: 2**

1. Assignments on class, constructor, overloading, inheritance, overriding
2. Assignments on wrapper class, arrays
3. Assignments on developing interfaces- multiple inheritance, extending interfaces
4. Assignments on creating and accessing packages
5. Assignments on multithreaded programming
6. Assignments on applet programming

**Paper Name: Language Practice Lab**

**Code: HU591**

**Contacts: 3P**

**Credits: 2**

- a) Honing 'Listening Skill' and its sub skills through Language Lab Audio device; 3P
- b) Honing 'Speaking Skill' and its sub skills; 2P
- c) Helping them master Linguistic/Paralinguistic features (Pronunciation/Phonetics/Voice modulation/Stress/Intonation/ Pitch &Accent) of connected speech; 2P
- j) Honing 'Conversation Skill' using Language Lab Audio –Visual input; Conversational Practice Sessions (Face to Face / via Telephone , Mobile phone & Role Play Mode); 2P
- k) Introducing 'Group Discussion' through audio –Visual input and acquainting them with key strategies for success; 2P
- f) G D Practice Sessions for helping them internalize basic Principles (turn- taking, creative intervention, by using correct body language, courtesies & other soft skills) of GD; 4P
- g) Honing 'Reading Skills' and its sub skills using Visual / Graphics/Diagrams /Chart Display/Technical/Non Technical Passages; Learning Global / Contextual / Inferential Comprehension; 2P
- h) Honing 'Writing Skill' and its sub skills by using Language Lab Audio –Visual input; Practice Sessions 2P

Total Practical Classes 17

**Books Recommended:**

Dr. D. Sudharani: Manual for English Language Laboratory

Pearson Education (WB edition),2010

Board of Editors: Contemporary Communicative English for Technical Communication, Pearson Longman, 2010

# JIS College of Engineering

(An Autonomous Institution)

Department of Computer Science and Engineering

Full Curriculum and Syllabus of B.Tech. in Computer Science and Engineering

Programme under Autonomous Framework

1<sup>st</sup> to 8<sup>th</sup> Semester. September 2015 reprint following 5<sup>th</sup> BOS meeting dated 24.09.2015

## 6<sup>th</sup> Semester

A.Theory						
Sl. No.	Paper Code	Paper Name	Contact hours/week			Credit points
			L	T	P Total	
1	CS 601	Database Management System	3	1	0 4	4
2	CS 602	Computer Graphics& Multimedia	3	0	0 3	3
3	CS 603	Software Engineering	3	0	0 3	3
4	CS 604	Web Technology	3	0	0 3	3
5	CS 605	Formal Language & Automata Theory	3	0	0 3	3
6	F.E. HU 601(E)	Business English	3	0	0 3	3
		<b>Total of Theory</b>			<b>19</b>	<b>19</b>
B. Practicals						
Sl. No.	Paper Code	Paper Name	Contact hours/week			Credit points
			L	T	P Total	
1	CS 691	Database Management System Lab	0	0	3 3	2
2	CS 692	Computer Graphics & MultimediaLab	0	0	3 3	2
3	CS 693	Software Engg lab	0	0	3 3	2
4	CS 694	Web Technology Lab	0	0	3 3	2
5	CS 681	Mini Project /Presentation	0	0	3 3	2
		<b>Total of Practicals</b>			<b>15</b>	<b>10</b>
		<b>Total of Semester</b>			<b>34</b>	<b>29</b>

# JIS College of Engineering

(An Autonomous Institution)

Department of Computer Science and Engineering

Full Curriculum and Syllabus of B.Tech. in Computer Science and Engineering

Programme under Autonomous Framework

1<sup>st</sup> to 8<sup>th</sup> Semester. September 2015 reprint following 5<sup>th</sup> BOS meeting dated 24.09.2015

## 6<sup>th</sup> Semester

**Paper Name: Database Management System**

**Code: CS 601**

**Contacts: 3L+1T**

**Credits: 4**

**Allotted hours: 43L**

### **Introduction:**

Introduction to database Systems, Basic concepts & Definitions, Data Dictionary, DBA, File-oriented system vs. Database System, Database Language. Database System Architecture-Schemas, Sub Schemas & Instances, 3-level database architecture, Data Abstraction, Data Independence, Mappings, Structure, Components & functions of DBMS, Data models, Mapping E-R model to Relational, Network and Object Oriented Data models, types of Database systems.

### **Introduction to the Relational Model:**

Integrity Constraint Over relations , Enforcing Integrity constraints , Querying relational data , Logical data base Design , Introduction to Views , Destroying /altering Tables and Views.

**Relational Algebra:** Selection and projection set operations , renaming, Joins , Division , Examples of Algebra overviews.

**Relational calculus:** Tuple and Domain relational Calculus

### **Form of Basic SQL Query:**

Examples of Basic SQL Queries, Introduction to Nested Queries ,Correlated Nested Queries Set ,Comparison Operators, Aggregative Operators, NULL values , Comparison using Null values, Logical connectivity's, AND, OR and NOT, Impact on SQL Constructs , Outer Joins, Disallowing NULL values, Complex Integrity Constraints in SQL Triggers and Active Data bases.

### **Schema Refinement :**

Problems Caused by redundancy, Decompositions , Problem related to decomposition , reasoning about FDS, FIRST, SECOND, THIRD Normal forms, BCNF ,Lossless join Decomposition, Dependency preserving Decomposition, Schema refinement in Data base Design, Multi valued Dependencies, FORTH Normal Form.

### **Transaction Concept:**

Transaction processing and concurrency control: Transaction State, Implementation of Atomicity and Durability, Concurrent Executions, Serializability, Recoverability ,Implementation of Isolation, Testing for serializability. Locking and Timestamp methods for concurrency control.

Database Recovery System: Types of Data Base failure & Types of Database Recovery, Recovery techniques

### **Storage and Indexing :**

Detailed Storage Architecture, Storing Data, Magnetic Disk, RAID, Other Disks, Magnetic Tape, Storage Access, File & Record Organization, Indexing, Cluster Indexes, Primary and Secondary Indexes , Index data Structures .

### **Tree Structured Indexing :**

Intuitions for tree Indexes, Indexed Sequential Access Methods (ISAM)

B+ Trees: A Dynamic Index Structure.

### **Text Book:**

A.Silberschatz et.al - Database System Concepts, 5th Edn, Tata Mc-Graw Hill

### **Reference Books:**

1. Date C.J. - An Introduction to Database System, Pearson Education
2. R.Elmasri, Fundamentals of Database Systems, Pearson Education

# JIS College of Engineering

(An Autonomous Institution)

Department of Computer Science and Engineering

Full Curriculum and Syllabus of B.Tech. in Computer Science and Engineering

Programme under Autonomous Framework

1<sup>st</sup> to 8<sup>th</sup> Semester. September 2015 reprint following 5<sup>th</sup> BOS meeting dated 24.09.2015

**Paper Name: Computer Graphics & Multimedia**

**Code: CS 602**

**Contacts: 3L**

**Credits: 3**

**Allotted hours: L**

## **Introduction to computer graphics**

**6L**

Overview of computer graphics, representing pictures, preparing, presenting & interacting with pictures for presentations; RGB color model, CRT, Raster scan display, Random scan display, LCD display, LED display, representing color using lookup table.

## **Scan conversion**

**7L**

Line drawing algorithms; DDA algorithm, Bresenham's line algorithm, Circle generating algorithm; Ellipse generating algorithm; scan line polygon fill algorithm, boundary fill algorithm, flood fill algorithm, aliasing, anti-aliasing.

## **2D transformation & viewing**

**7L**

Basic transformations: translation, rotation, scaling, reflection, shearing, Matrix representations & homogeneous coordinates, Viewing pipeline, Window to viewport co-ordinate transformation, Clipping: point clipping, line clipping (Cohen Sutherland, Cyrus Beck), clipping circles, polygon clipping (Sutherland-Hodgeman, Weiler Atherton Polygon clipping)

## **3D transformation & viewing**

**5L**

3D transformations: translation, rotation, scaling & other transformations. Rotation about an arbitrary axis in space, reflection through an arbitrary plane; 3D Viewing, 3D clipping, Projection: Parallel, Perspective.

## **Curves**

**3L**

Curve representation, Spline: Hermite Cubic curves, Bezier curves, B-spline curves

## **Hidden surfaces**

**5L**

Depth comparison, Z-buffer algorithm, A-buffer algorithm, Back face detection, BSP tree method, Painter's algorithm, scan-line algorithm.

## **Color & Illumination models**

**5L**

Light & color model: RGB, CMY Model, different illumination models, ray tracing, shading models- Phong shading, Gourand shading.

## **Multimedia**

**5L**

Introduction to Multimedia: Concepts, uses of multimedia, hypertext and hypermedia; Image, video and audio standards.

Audio: digital audio, MIDI, processing sound, sampling, compression.

Video: MPEG compression standards, inter-frame and intraframe compression.

Animation: types, techniques, morphing.

## **Recommended reference Books:**

1. Hearn, Baker – Computer Graphics (C version 2<sup>nd</sup> Ed.) – Pearson education
2. Z. Xiang, R. Plastock – “Schaum's outlines Computer Graphics (2<sup>nd</sup> Ed.) – TMH
3. Mukherjee- Fundamentals of Computer graphics & Multimedia, PHI
4. Mukherjee Arup- Introduction to Computer Graphics, Vikas
5. Udit Agarwal- Computer Graphics, Katson Books

# JIS College of Engineering

(An Autonomous Institution)

Department of Computer Science and Engineering

Full Curriculum and Syllabus of B.Tech. in Computer Science and Engineering

Programme under Autonomous Framework

*1<sup>st</sup> to 8<sup>th</sup> Semester. September 2015 reprint following 5<sup>th</sup> BOS meeting dated 24.09.2015*

**Paper Name: Software Engineering**

**Code: CS 603**

**Contacts: 3L**

**Credits: 3**

**Allotted hours: 32L**

## **Module I**

Software Engineering –Characteristics, Components, Application, Definitions, Software Process models - Waterfall Model, Prototype model, RAD, Evolutionary Models, Incremental, Spiral, Concepts of project management, Role of Metrics and Management **(4L)**

## **Module II**

Software Project Planning- Feasibility Analysis, Technical Feasibility, Cost- Benefit Analysis, COCOMO model, System Analysis: Principle of Structure Analysis, Requirement Analysis, DFD, Entity Relationship Diagram, Data Dictionary, Data Modeling, Software Requirements Specification **(5L)**

## **Module III**

Software Design Aspects: Objectives, Principles, Concepts, Top-Down and Bottom-Up design; Decision tree, decision table and structured English, Structure chart, Transform analysis Functional Vs. Object- Oriented approach. **[3L]**

## **Module IV**

### **Unified Modelling Language**

Class diagram, interaction diagram: collaboration diagram, sequence diagram, state chart diagram, activity diagram, implementation diagram. **(4L)**

## **Module V**

Coding & Documentation – Structured Programming, Modular Programming, Module Relationship- Coupling, Cohesion, OO Programming, Information Hiding, Reuse, System Documentation. **[5L]**

Testing – Levels of Testing, Integration Testing, System Testing. **(5L)**

Test Cases- White Box and Black Box testing Software Quality, Quality Assurance, Software Maintenance, Software Configuration Management, Software Architecture. **[6L]**

Reference Books:

1. Software Engineering : A practitioner's approach– Pressman(TM)
2. Software Engineering- Pankaj Jalote (Wiley-India)
3. Software Engineering- Rajib Mall (PHI)
4. Software Engineering –Agarwal and Agarwal (PHI)

# JIS College of Engineering

(An Autonomous Institution)

Department of Computer Science and Engineering

Full Curriculum and Syllabus of B.Tech. in Computer Science and Engineering

Programme under Autonomous Framework

*1<sup>st</sup> to 8<sup>th</sup> Semester. September 2015 reprint following 5<sup>th</sup> BOS meeting dated 24.09.2015*

**Paper Name: Web Technology**

**Code: CS 604**

**Contacts: 3L**

**Credits: 3**

**Allotted hours: 38L**

Static Web Pages [6L]

Web Pages - types and issues, tiers; comparisons of Microsoft and java technologies, WWW(Basic concepts,webclientandwebserver,httpprotocol frameformat),universalresource locator(url),HTML(differenttags,sections,image&pictures,listings, tables, frame, frameset, form.

Dynamic Web Pages [2L]

The need of dynamic web pages; an overview of DHTML, cascading style sheet(css), Comparative studies of different technologies of dynamic page creation.

Active Web Pages [2L]

Need of active web pages: java applet lifecycle.

Java Script [3L]

Datatypes,variables,operators,conditionalstatements,arrayobject,dateobject,stringobject.

Java Servlet [4L]

Servletenvironmentandrole,HTMLsupport,ServletAPI,Theservletlifecycle,Cookiesand Sessions.

JSP [10L]

JSP architecture, JSP servers, JSP tags, understanding the layout in JSP, Declaring variables, methods in JSP, inserting java expression in JSP, processing request from user and generating dynamic response for the user ,inserting applets and javabeans into JSP, using include and forward action, comparing JSP and CGI program, comparing JSP and ASP program; Creating ODBC data source name, introduction to JDBC,preparedstatement andcallablestatement.

J2EE[5L]

AnoverviewofJ2EEwebservices,basicsofEnterpriseJavaBeans,EJBvs.JavaBeans, basicsofRMI.

XML [6L]

Extensible Markup Language (XML), basics of XML, elements and attributes, document type definition, XMLparsers,sequentialandtreeapproach.

## **Books:**

1. WebTechnologies(GodboleA.S.&KahateA.,TMH.
2. WebTechnology&Design(XavierC.,NewAgePublication.
3. JavaServerProgramming,J2EEedition.(VOLIandVOLII);WROXpublishers.



# JIS College of Engineering

(An Autonomous Institution)

Department of Computer Science and Engineering

Full Curriculum and Syllabus of B.Tech. in Computer Science and Engineering

Programme under Autonomous Framework

1<sup>st</sup> to 8<sup>th</sup> Semester. September 2015 reprint following 5<sup>th</sup> BOS meeting dated 24.09.2015

**Paper Name: Formal Language & Automata Theory**

**Code: CS 605**

**Contacts: 3L**

**Credits: 3**

**Allotted hours: 36L**

Prerequisites of Formal Language & Automata Theory:

Elementary discrete mathematics including the notion of set, function, relation, product, partial order, equivalence relation, graph & tree. They should have a thorough understanding of the principle of mathematical induction.

Module-1: [13 L]

Fundamentals: Basic definition of sequential circuit, block diagram, mathematical representation, concept of transition table and transition diagram (Relating of Automata concept to sequential circuit concept)

Design of sequence detector, Introduction to finite state model [2L]

Finite state machine: Definitions, capability & state equivalent, kth- equivalent concept [1L]

Merger graph, Merger table, Compatibility graph [1L]

Finite memory definiteness, testing table & testing graph. [1L]

Deterministic finite automaton and non deterministic finite automaton. [1L] Transition diagrams and Language recognizers. [1L]

Finite Automata: NFA with  $\hat{\Gamma}$  transitions - Significance, acceptance of languages. [1L]

Conversions and Equivalence: Equivalence between NFA with and without  $\hat{\Gamma}$  transitions. NFA to DFA conversion. [2L]

Minimization of FSM, Equivalence between two FSM's, Limitations of FSM [1L]

Application of finite automata, Finite Automata with output- Moore & Melay machine. [2L]

Learning outcome of Finite Automata:

The student will be able to define a system and recognize the behavior of a system. They will be able to minimize a system and compare different systems.

Module-2: [8 L]

Regular Languages : Regular sets. [1L]

Regular expressions, identity rules. Arden's theorem state and prove [1L]

Constructing finite Automata for a given regular expressions, Regular string accepted by NFA/DFA [1L]

Pumping lemma of regular sets. Closure properties of regular sets (proofs not required). [1L]

Grammar Formalism: Regular grammars-right linear and left linear grammars. [1L]

Equivalence between regular linear grammar and FA. [1L]

Inter conversion, Context free grammar. [1L]

Derivation trees, sentential forms. Right most and leftmost derivation of strings. (Concept only) [1L]

Learning outcome of Regular Languages and Grammar:

Student will convert Finite Automata to regular expression. Students will be able to check equivalence between regular linear grammar and FA.

Module-3: [9L]

Context Free Grammars, Ambiguity in context free grammars. [1L]

Minimization of Context Free Grammars. [1L]

Chomsky normal form and Greibach normal form. [1L]

Pumping Lemma for Context Free Languages. [1L]

Enumeration of properties of CFL (proofs omitted). Closure property of CFL, Ogden's lemma & its applications [1L]

Push Down Automata: Push down automata, definition. [1L]

Acceptance of CFL, Acceptance by final state and acceptance by empty state and its equivalence. [1L]

# JIS College of Engineering

(An Autonomous Institution)

Department of Computer Science and Engineering

Full Curriculum and Syllabus of B.Tech. in Computer Science and Engineering

Programme under Autonomous Framework

*1<sup>st</sup> to 8<sup>th</sup> Semester. September 2015 reprint following 5<sup>th</sup> BOS meeting dated 24.09.2015*

Equivalence of CFL and PDA, interconversion. (Proofs not required). [1L]

Introduction to DCFL and DPDA. [1L]

Learning outcome of PDA and context free grammar:

Students will be able to minimize context free grammar. Student will be able to check equivalence of CFL and PDA. They will be able to design Turing Machine.

Module-4: [6L]

Turing Machine : Turing Machine, definition, model [1L]

Design of TM, Computable functions [1L]

Church's hypothesis, counter machine [1L]

Types of Turing machines (proofs not required) [1 L]

Universal Turing Machine, Halting problem [2L]

Learning outcome of Turing Machine :

Students will be able to design Turing machine.

## TEXT BOOKS:

"Introduction to Automata Theory Language and Computation", Hopcroft H.E. and Ullman J. D., Pearson Education.

"Theory of Computer Science ", Automata Languages and computation", Mishra and Chandrashekar, 2<sup>nd</sup> edition, PHI.

"Formal Languages and Automata Theory", C.K.Nagpal, Oxford

## REFERENCES:

"Switching & Finite Automata", ZVI Kohavi, 2nd Edn., Tata McGraw Hill

"Introduction to Computer Theory", Daniel I.A. Cohen, John Wiley

"Introduction to languages and the Theory of Computation", John C Martin, TMH

"Elements of Theory of Computation", Lewis H.P. & Papadimitrou C.H. Pearson, PHI.

## Lab

# JIS College of Engineering

(An Autonomous Institution)

Department of Computer Science and Engineering

Full Curriculum and Syllabus of B.Tech. in Computer Science and Engineering

Programme under Autonomous Framework

*1<sup>st</sup> to 8<sup>th</sup> Semester. September 2015 reprint following 5<sup>th</sup> BOS meeting dated 24.09.2015*

**Paper Name: Database Management System Lab**

**Code: CS 691**

**Contacts: 3P**

**Credits: 2**

1. Data Definition, Table Creation, Constraints (Creation and inserting rows into a table (use constraints while creating tables)) examples using SELECT command. Queries using ANY, ALL, IN, EXISTS, NOTEXISTS,
2. Update, Alter and Delete Commands. (Queries using (COUNT, SUM, AVG, MAX and MIN), order by GROUP BY, LIKE OPERATOR and HAVING.
3. Nested Queries and Join Queries
4. Creation and dropping of Views. Queries using Conversion functions (to\_char, to\_number and to\_date), string functions (Concatenation, lpad, rpad, ltrim, rtrim, lower, upper, initcap, length, substr and instr), date functions (Sysdate, next\_day, add\_months, last\_day, months\_between, least, greatest, trunc, round, to\_char, to\_date)
5. Creation of simple PL/SQL program which includes declaration section, executable section and exception –Handling section (Ex. Student marks can be selected from the table and printed for those who secured first class and an exception can be raised if no records were found).
6. Develop a program that includes the features NESTED IF, CASE and CASE expression. The program can be extended using the NULLIF and COALESCE functions.
7. Program development using WHILE LOOPS, numeric FOR LOOPS, nested loops using ERROR Handling, BUILT –IN Exceptions, USE defined Exceptions, RAISE- APPLICATION ERROR
8. Programs development using creation of procedures, passing parameters IN and OUT of PROCEDURES. ( Problem on procedure)
9. Program development using creation of stored functions, invoke functions in SQL Statements and write complex functions.
10. Develop Programs using BEFORE and AFTER Triggers, Row and Statement Triggers and INSTEAD OF Triggers
11. Database Design and implementation (Mini Project).
11. Develop programs using features parameters in a CURSOR, FOR UPDATE CURSOR, WHERE CURRENT of clause and CURSOR variables.
12. Program development using creation of package specification, package bodies, private objects, package variables and cursors and calling stored packages.

**Paper Name: Computer Graphics & Multimedia Lab**

# JIS College of Engineering

(An Autonomous Institution)

Department of Computer Science and Engineering

Full Curriculum and Syllabus of B.Tech. in Computer Science and Engineering

Programme under Autonomous Framework

*1<sup>st</sup> to 8<sup>th</sup> Semester. September 2015 reprint following 5<sup>th</sup> BOS meeting dated 24.09.2015*

**Code: CS 692**

**Contacts: 3P**

**Credits: 2**

## **1. Scan Conversion [9P]**

Implementation of DDA Line Drawing Algorithm.

Implementation of Bresenham's Line Algorithm.

Implementation of Circle Generating Algorithm.

## **2. 2D Transformation [6P]**

Implementation of two dimensional transformation- translation, rotation, scaling, shearing, reflection.

Implementation of Composite 2D transformation.

## **3. Filling Algorithm [6P]**

Implementation of boundary fill algorithm.

Implementation of flood fill algorithm.

Implementation of scan line polygon fill algorithm.

## **4. Clipping & Fractals [9P]**

Implementation of windowing & clipping for points, lines (Cohen-Sutherland), polygons (Sutherland-Hodgeman, Weiler Atherton)

Implementation of simple fractal representation.

## **5. Multimedia [6P]**

Web document creation using Dreamweaver. Creating Animation using Flash/Maya.

## **Paper Name: Software Engg lab**

**Code: CS 693**

**Contacts: 3P**

**Credits: 2**

### **Assignments to be given from the following**

1. Preparation of requirement document for standard application problems in standard format.(e.g. Library Management System, Railway Reservation system, Hospital management System, University Admission system)

2. Project Schedule preparation.

3. Use Case diagram, Class diagram, Sequence diagram and prepare Software Design Document using tools like Rational Rose. (For standard application problems)

4. Estimation of project size using Function Point (FP) for calculation.

5. Design Test Script/Test Plan (both Black box and White Box approach)

6. Compute Process and Product Metrics (e.g. Defect Density, Defect Age, Productivity, Cost etc.) Also by Cost Estimation models.

# JIS College of Engineering

(An Autonomous Institution)

Department of Computer Science and Engineering

Full Curriculum and Syllabus of B.Tech. in Computer Science and Engineering

Programme under Autonomous Framework

*1<sup>st</sup> to 8<sup>th</sup> Semester. September 2015 reprint following 5<sup>th</sup> BOS meeting dated 24.09.2015*

**Paper Name: Web Technology Lab**

**Code: CS 694**

**Contacts: 3P**

**Credits: 2**

1. Basic use of html tag, linking image table, frame, form design.
2. DHTML- inline styles, creating style sheets with the style element, linking external style sheet, positioning elements, user style sheet.
3. Creating event handler that respond to mouse and keyboard event: Onload, onmouseover, onmouseout, onfocus, onblur, onsubmit, onresult, onclick, onchange.
4. Structuring data with xml, xml parser, extensible style language (xsl); customising markup language.
5. Configuring apache-tomcat server.
6. Building simple jsp: Declaring variables and methods in jsp, inserting java expression in jsp, processing request from user, generating dynamic response for the user. Accessing database from jsp, inserting applet into jsp.

Books:-

1. JAVA Server Pages - Hans Bergstein – O'Reilly.
2. Web Technologies - Godbole A. S. & Kahate A., TMH.
3. Web Technology & Design - Xavier C., New Age Publication.
4. Java Server Programming, J2EE edition. (VOL I and VOL II); WROX publishers.

**Paper Name: Mini Project/Presentation**

**Code: CS 681**

**Contacts: 3P**

**Credits: 2**

1. Notification of Project/Presentation
2. Group Submission
3. Notification of Domain Name
4. Supervisor Selection
5. Project Allocation
6. Project Evaluation by Execution
7. End Semester Examination through report and project presentation

# JIS College of Engineering

(An Autonomous Institution)

Department of Computer Science and Engineering

Full Curriculum and Syllabus of B.Tech. in Computer Science and Engineering

Programme under Autonomous Framework

1<sup>st</sup> to 8<sup>th</sup> Semester. September 2015 reprint following 5<sup>th</sup> BOS meeting dated 24.09.2015

## 7<sup>th</sup> Semester

<b>A. Theory</b>						
Sl. No.	Paper Code	Paper Name	Contact hours/week			Credit points
			L	T	P Total	
1	HU 701	Values & Ethics in Profession	3	0	0 3	3
2	CS 701	Compiler Design	3	1	0 4	4
3	CS 702	Soft Computing	3	1	0 4	4
4	CS 703	Elective I A. Mobile Computing B. Distributed Operating Systems C. Cloud Computing D. E-Commerce E. CAD VLSI	3	1	0 4	4
5	CS 704	Elective II A. Natural Language Processing B. Distributed DBMS C. Robotics D. Internet Technology E. Artificial Intelligence	3	1	0 4	4
<b>Total of Theory</b>			<b>19</b>			<b>19</b>
<b>B. Practical</b>						
Sl. No.	Paper Code	Paper Name	Contact hours/week			Credit points
			L	T	P Total	
1	CS 791	Compiler Design Lab	0	0	3 3	2
2	CS 792	Soft Computing Lab	0	0	3 3	2
3	CS 781	Assigned Project	0	0	3 3	4
4	CS 782	Seminar-I	0	0	3 3	2
5	CS 783	Practical Training Evaluation	0	0	3 3	2
<b>Total of Practical</b>			<b>15</b>			<b>12</b>
<b>Total of Semester</b>			<b>34</b>			<b>31</b>

# JIS College of Engineering

(An Autonomous Institution)

Department of Computer Science and Engineering

Full Curriculum and Syllabus of B.Tech. in Computer Science and Engineering

Programme under Autonomous Framework

1<sup>st</sup> to 8<sup>th</sup> Semester. September 2015 reprint following 5<sup>th</sup> BOS meeting dated 24.09.2015

## 7<sup>th</sup> Semester

**Paper Name: Values & Ethics in Profession**

**Code: HU 701**

**Contacts: 3L**

**Credits: 3**

**Allotted hours: 30L**

### Group-A

Science, Technology and Engineering as knowledge and as Social and Professional Activities

#### ***Effects of Technological Growth:***

Rapid Technological growth and depletion of resources, Reports of the Club of Rome. Limits of growth: sustainable development

Energy Crisis: Renewable Energy Resources

Environmental degradation and pollution. Eco-friendly Technologies. Environmental Regulations, Environmental Ethics Appropriate Technology Movement of Schumacher; later developments Technology and developing notions. Problems of Technology transfer, Technology assessment impact analysis.

Human Operator in Engineering projects and industries. Problems of man, machine, interaction, Impact of assembly line and automation. Human centered Technology.

### Group-B

#### ***Ethics of Profession:***

Engineering profession: Ethical issues in Engineering practice, Conflicts between business demands and professional ideals. Social and ethical responsibilities of Technologists. Codes of professional ethics. Whistle blowing and beyond, Case studies.

#### ***Profession and Human Values:***

Values Crisis in contemporary society

Nature of values: Value Spectrum of a good life

Psychological values: Integrated personality; mental health

Societal values: The modern search for a good society, justice, democracy, secularism, rule of law, values in Indian Constitution.

Aesthetic values: Perception and enjoyment of beauty, simplicity, clarity

Moral and ethical values: Nature of moral judgements; canons of ethics; ethics of virtue; ethics of duty; ethics of responsibility.

#### **Books:**

1. Stephen H Unger, Controlling Technology: Ethics and the Responsible Engineers, John Wiley & Sons,

New York 1994 (2nd Ed)

2. Deborah Johnson, Ethical Issues in Engineering, Prentice Hall, Englewood Cliffs, New Jersey 1991.

3. A N Tripathi, Human values in the Engineering Profession, Monograph published by IIM, Calcutta 1996.

# JIS College of Engineering

(An Autonomous Institution)

Department of Computer Science and Engineering

Full Curriculum and Syllabus of B.Tech. in Computer Science and Engineering

Programme under Autonomous Framework

*1<sup>st</sup> to 8<sup>th</sup> Semester. September 2015 reprint following 5<sup>th</sup> BOS meeting dated 24.09.2015*

**Paper Name: Compiler Design**

**Code: CS 701**

**Contacts: 3L+1T**

**Credits: 4**

**Allotted hours: 40L**

## **Module I: Introduction**

**[2L]**

Compilers, Analysis-synthesis model, The phases of the compiler.

## **Module II: Lexical Analysis**

**[5L]**

The role of the lexical analyzer, Tokens, Patterns, Lexemes, Input buffering, Specifications of a token, Recognition of tokens, Finite automata, From a regular expression to an NFA, From a regular expression to NFA, From a regular expression to DFA, Design of a lexical analyzer generator (Lex).

## **Module III :Syntax Analysis**

**[14L]**

The role of a parser, Context free grammars, Writing a grammar, Top down Parsing, Non recursive Predictive parsing (LL), Bottom up parsing, Handles, Viable prefixes, Operator precedence parsing, LR parsers (SLR, LALR, Canonical LR), Parser generators (YACC). Error Recovery strategies for different parsing techniques.

Syntax directed translation: Syntax directed definitions, Construction of syntax trees, Bottom-up evaluation of S-attributed definitions, L-attributed definitions, Bottom-up evaluation of inherited attributes.

## **Module IV: Type checking**

**[3L]**

Type systems, Specification of a simple type checker, Equivalence of type expressions, Type conversions

## **Module V: Run time environments**

**[4L]**

Source language issues (Activation trees, Control stack, scope of declaration, Binding of names), Symbol tables, dynamic storage allocation techniques.

## **Module VI: Intermediate code generation**

**[3L]**

Intermediate languages, Graphical representation, Three-address code, Implementation of three address statements (Quadruples, Triples, Indirect triples).

## **Module VII: Code optimization**

**[6L]**

Consideration for Optimization, scope of optimization, local optimization, loop optimization, folding, DAG representation, Flow Graph, Data flow equation, global optimization, redundant sub expression elimination, induction variable elimination, copy propagation, basic blocks & flow graphs, transformation of basic blocks, DAG representation of basic blocks, peephole optimization

## **Module VIII: Code Generation**

**[3L]**

Object code forms, machine dependent code optimization, register allocation and assignment, generic code generation algorithms, DAG for register allocation.

### **Recommended reference Books:**

1. Aho, Sethi, Ullman - "Compiler Principles, Techniques and Tools" - Pearson Education.
2. Holub - "Compiler Design in C" – PHI
3. Chattopadhyay , S- Compiler Design ( PHI)



# JIS College of Engineering

(An Autonomous Institution)

Department of Computer Science and Engineering

Full Curriculum and Syllabus of B.Tech. in Computer Science and Engineering

Programme under Autonomous Framework

1<sup>st</sup> to 8<sup>th</sup> Semester. September 2015 reprint following 5<sup>th</sup> BOS meeting dated 24.09.2015

**Paper Name: Soft Computing**

**Code: CS 702**

**Contacts: 3L+1T**

**Credits: 4**

**Allotted hours: 36L**

## **Soft Computing: Module-I**

[6L]

1. Soft Computing: Introduction of soft computing, soft computing vs. hard computing, various types of soft computing techniques, applications of soft computing.
2. Artificial Intelligence : Introduction, Various types of production systems, characteristics of production systems, breadth first search, depth first search techniques, other Search Techniques like hill Climbing, Best first Search, A\* algorithm, AO\* Algorithms and various types of control

## **Soft Computing: Module-II**

[10L]

1. Introduction to derivative free optimization, GA; biological background, search space of genetic algorithm, genetic algorithm Vs. Traditional algorithm; Simple genetic algorithm,
2. Genetic algorithm Operators: Encoding, selection criteria, Crossover, Mutation, advantages and disadvantages of genetic algorithm, Convergence of GA, Applications & advances in GA, Differences & similarities between GA & other traditional method.

## **Soft Computing: Module-III**

[10L]

1. Neural Network : Biological neuron, artificial neuron, definition of ANN, Taxonomy of neural net, Difference between ANN and human brain, Structure and Function of a single neuron, characteristics and applications of ANN, single layer network, Perceptron training algorithm, Linear separability, Widrow & Hebb;s learning rule/Delta rule, ADALINE, MADALINE, AI v/s ANN.
2. Introduction of MLP, different activation functions, Error back propagation algorithm, derivation of EBPA, momentum, heuristic, limitation, characteristics and application of EBPA.
3. Adaptive Resonance Theory: Architecture, classifications, Implementation and training, Associative Memory.

## **Soft Computing: Module-IV**

[10L]

1. Fuzzy Logic: Fuzzy set theory, Fuzzy set versus crisp set, Crisp relation & fuzzy relations, Fuzzy systems: crisp logic, fuzzy logic, introduction & features of membership functions,
2. Fuzzy rule base system: fuzzy propositions, formation, decomposition & aggregation of fuzzy rules, fuzzy reasoning, fuzzy inference systems, fuzzy decision making & Applications of fuzzy logic.

### **Text Books:**

1. Fuzzy logic with engineering applications, Timothy J. Ross, John Wiley and Sons.
2. S. Rajasekaran and G.A.V.Pai, "Neural Networks, Fuzzy Logic and Genetic Algorithms", PHI
3. S. N. Sivanandam, S.N. Deepa; " Principles of Soft Computing" , Willey – India.
4. Amit Konar, "Artificial Intelligence and Soft Computing: Behavioral and Cognitive Modeling of the Human Brain" ; CRC Press; ISBN-10: 0849313856 , ISBN-13: 978-0849313851.
5. Neural Networks: A Comprehensive Foundation (2nd Edition), Simon Haykin, Prentice Hall.

### **Reference Books:**

1. K.H.Lee. First Course on Fuzzy Theory and Applications, Springer-Verlag.
2. J. Yen and R. Langari.. Fuzzy Logic, Intelligence, Control and Information, Pearson Education.

# JIS College of Engineering

(An Autonomous Institution)

Department of Computer Science and Engineering

Full Curriculum and Syllabus of B.Tech. in Computer Science and Engineering

Programme under Autonomous Framework

*1<sup>st</sup> to 8<sup>th</sup> Semester. September 2015 reprint following 5<sup>th</sup> BOS meeting dated 24.09.2015*

## Elective I

**Paper Name: Mobile Computing**

**Code: CS 703A**

**Contacts: 3L+1T**

**Credits: 4**

**Allotted hours:42 L**

MODULE - I Introduction to Mobile Communications and Computing. GSM : Mobile services, System architecture, Radio interface, Protocols, Localization and calling, Handover, Security and New data services. 6L

MODULE – II Mobile IP: Goals, assumptions, entities and terminology, IP packet delivery, agent advertisement and discovery, registration, tunneling and encapsulation, optimizations. 4L

MODULE - III Traditional TCP, Indirect TCP, Snooping TCP, Mobile TCP, Fast retransmit/fast recovery, Transmission /time-out freezing, Selective retransmission, Transaction oriented TCP. 6L

MODULE - IV Data Dissemination: Communications asymmetry, classification of new data delivery mechanisms, push-based mechanisms, pull-based mechanisms, hybrid mechanisms, selective tuning (indexing) techniques. 5L

MODULE - V General Packet Radio Services (GPRS): GPRS Architecture, GPRS Network Nodes. WLANs (Wireless LANs) IEEE 802.11 standard: System architecture, Protocol architecture. 5L

MODULE - VI Wireless Application Protocol-WAP: Introduction, protocol architecture, and treatment of protocols of all layers, Introduction to Wireless Markup Language (WML). Bluetooth: User scenarios, physical layer, MAC layer, networking, security, link management. 8L

MODULE - VII Global Mobile Satellite Systems: Case studies of the IRIDIUM and GLOBALSTAR systems. Third Generation (3G) Mobile Services: Introduction to International Mobile Telecommunications 2000 (IMT 2000), Introduction to Wideband Code Division Multiple Access (W-CDMA) and CDMA 2000. 8L

Text Books:

1. "Mobile Communication", J. Schiller, Pearson.
2. "Mobile and Personal Communication systems and services", Raj Pandya, Prentice Hall of India.
3. "Mobile Computing", Rajkamal, Oxford University Press.

# JIS College of Engineering

(An Autonomous Institution)

Department of Computer Science and Engineering

Full Curriculum and Syllabus of B.Tech. in Computer Science and Engineering

Programme under Autonomous Framework

*1<sup>st</sup> to 8<sup>th</sup> Semester. September 2015 reprint following 5<sup>th</sup> BOS meeting dated 24.09.2015*

**Paper Name: Distributed Operating Systems**

**Code: CS 703B**

**Contacts: 3L+1T**

**Credits: 4**

**Allotted hours: 42L**

1. Fundamentals: Distributed computing, system model, distributed operating system, designing operating system, Introduction to DCE [2L].
2. Message Passing : Desirable features message passing system, Issues in message passing, synchronization, buffering, multidatagram messages , Encoding and decoding of message data, Process addressing, Failure handling, Group communication [2L].
3. Remote procedure call: RPC model, Transparency of RPC, implementing RPC mechanism, Lightweight RPC, Optimizations for better performance [2L].
4. Distributed Shared Memory and Naming: Architecture, Algorithms for implementing DSM. Memory Coherence, Naming: Introduction, Desirable features of Naming system, Fundamental concepts, System oriented Names, Object locating mechanisms, human oriented Names, Name Caches and Naming and Security [7L].
5. Distributed mutual exclusion, Token and non-token based Algorithms, Distributed Deadlock, Centralized and Distributed deadlock detection algorithms [10L]
6. Synchronization: Inherent Limitations of distributed Systems. Lamport's Logical clock. Global State recording [3L].
7. Distributed File Systems: Introduction, good features of DFS, File models, File Accessing models, File sharing Semantics, File-Caching Schemes, File Replication, Fault Tolerance, Atomic Transactions and design principles [8L].
8. Protection and Security:  
Requirements for protection and security regimes. The access matrix model of protection. System and user modes, rings of protection, access lists, capabilities. User authentication, passwords and signatures. Use of single key and public key encryption [8L].

## **Books:**

- 1 Andrew S. Tanenbaum and Maarten Van Steen, Distributed Systems Principles and Paradigms, PHI
2. Singhal Mukesh & Shivaratri N. G., Advanced Concepts in Operating Systems, TMH
3. Tanenbaum, A. S. Distributed Operating Systems, (ISBN 0-131-439-340), Prentice Hall
4. Tanenbaum, A. S. Modern Operating Systems, 2<sup>nd</sup> Edition (ISBN 0-13-031358-0), Prentice Hall

# JIS College of Engineering

(An Autonomous Institution)

Department of Computer Science and Engineering

Full Curriculum and Syllabus of B.Tech. in Computer Science and Engineering

Programme under Autonomous Framework

1<sup>st</sup> to 8<sup>th</sup> Semester. September 2015 reprint following 5<sup>th</sup> BOS meeting dated 24.09.2015

**Paper Name: Cloud Computing**

**Code: CS703C**

**Contacts: 3L+1T**

**Credits: 4**

**Allotted hours: 42L**

**Module 1:** Definition of Cloud Computing and its Basics 9L

1. Definition of Cloud Computing: Defining a Cloud, Cloud Types – NIST model, Cloud Cube model, Deployment models (Public, Private, Hybrid and Community Clouds), Service models – Infrastructure as a Service, Platform as a Service, Software as a Service with examples of services/ service providers, Cloud Reference model Characteristics of Cloud Computing – a shift in paradigm Benefits and advantages of Cloud Computing

2. Cloud Architecture:

A brief introduction on Composability, Infrastructure, Platforms, Virtual Appliances, Communication Protocols, Applications, Connecting to the Cloud by Clients

3. Services and Applications by Type

IaaS – Basic concept, Workload, partitioning of virtual private server instances, Pods, aggregations, silos

PaaS – Basic concept, tools and development environment with examples

SaaS - Basic concept and characteristics, Open SaaS and SOA, examples of SaaS platform

Identity as a Service (IDaaS)

Compliance as a Service (CaaS)

**Module 2:** Use of Platforms in Cloud Computing 12L

1. Concepts of Abstraction and Virtualization

Virtualization technologies : Types of virtualization (access, application, CPU, storage), Mobility patterns (P2V, V2V, V2P, P2P, D2C, C2C, C2D, D2D). Load Balancing and Virtualization: Basic Concepts, Network resources for load balancing, Advanced load balancing (including Application Delivery Controller and Application Delivery Network), Mention of The Google Cloud as an example of use of load balancing Hypervisors: Virtual machine technology and types, VMware vSphere Machine Imaging (including mention of Open Virtualization Format – OVF)

Porting of applications in the Cloud: The simple Cloud API and AppZero Virtual Application appliance

2. Concepts of Platform as a Service

Definition of services, Distinction between SaaS and PaaS (knowledge of Salesforce.com and Force.com), Application development. Use of PaaS Application frameworks

3. Use of Google Web Services

Discussion of Google Applications Portfolio – Indexed search, Dark Web, Aggregation and disintermediation, Productivity applications and service, Adwords, Google Analytics, Google Translate, a brief discussion on Google Toolkit (including introduction of Google APIs in brief), major features of Google App Engine service.

4. Use of Amazon Web Services

Amazon Web Service components and services: Amazon Elastic Cloud, Amazon Simple Storage system, Amazon Elastic Block Store, Amazon SimpleDB and Relational Database Service

5. Use of Microsoft Cloud Services

Windows Azure platform: Microsoft's approach, architecture, and main elements, overview of Windows Azure AppFabric, Content Delivery Network, SQL Azure, and Windows Live services

**Module 3 :** Cloud Infrastructure 7L

Types of services required in implementation – Consulting, Configuration, Customization and Support

1. Cloud Management

An overview of the features of network management systems and a brief introduction of related products from large cloud vendors, Monitoring of an entire cloud computing deployment stack – an overview with mention of some products, Lifecycle management of cloud services (six stages of lifecycle)

2. Concepts of Cloud Security

Cloud security concerns, Security boundary, Security service boundary, Overview of security mapping

# JIS College of Engineering

(An Autonomous Institution)

Department of Computer Science and Engineering

Full Curriculum and Syllabus of B.Tech. in Computer Science and Engineering

Programme under Autonomous Framework

*1<sup>st</sup> to 8<sup>th</sup> Semester. September 2015 reprint following 5<sup>th</sup> BOS meeting dated 24.09.2015*

Security of data: Brokered cloud storage access, Storage location and tenancy, encryption, and auditing and compliance Identity management (awareness of Identity protocol standards)

## **Module 4 : Concepts of Services and Applications**

8L

1. Service Oriented Architecture: Basic concepts of message-based transactions, Protocol stack for an SOA architecture, Event-driven SOA, Enterprise Service Bus, Service catalogs
2. Applications in the Cloud: Concepts of cloud transactions, functionality mapping, Application attributes, Cloud service attributes, System abstraction and Cloud Bursting, Applications and Cloud APIs
3. Cloud-based Storage: Cloud storage definition – Manned and Unmanned
4. Webmail Services: Cloud mail services including Google Gmail, Mail2Web, Windows Live Hotmail, Yahoo mail, concepts of Syndication services

## **Books Recommended:**

1. Cloud Computing Bible by Barrie Sosinsky, Wiley India Pvt. Ltd, 2013
2. Mastering Cloud Computing by Rajkumar Buyya, Christian Vecchiola, S. Thamarai Selvi, McGraw Hill Education (India) Private Limited, 2013
3. Cloud computing: A practical approach, Anthony T. Velte, Tata Mcgraw-Hill
4. Cloud Computing, Miller, Pearson
5. Building applications in cloud: Concept, Patterns and Projects, Moyer, Pearson

## **References:**

1. Cloud Computing – Second Edition by Dr. Kumar Saurabh, Wiley India

# JIS College of Engineering

(An Autonomous Institution)

Department of Computer Science and Engineering

Full Curriculum and Syllabus of B.Tech. in Computer Science and Engineering

Programme under Autonomous Framework

*1<sup>st</sup> to 8<sup>th</sup> Semester. September 2015 reprint following 5<sup>th</sup> BOS meeting dated 24.09.2015*

**Paper Name: E-Commerce**

**Code: CS 703D**

**Contacts: 3L+1T**

**Credits: 4**

**Allotted hours: 42L**

1. Electronic Commerce: Overview, Definitions, Advantages & Disadvantages of E-Commerce, Threats of E-Commerce, Managerial Prospective, Rules & Regulations for Controlling E-Commerce, Cyber Laws. [4 L]

2. Technologies: Relationship between E – Commerce & Networking, Different Types of Networking For E – Commerce, Internet, Intranet & Extranet, EDI Systems, Wireless Application Protocol: Definition, Hand Held Devices, Mobility & Commerce, Mobile Computing, Wireless Web, Web Security, Infrastructure Requirement For E – Commerce. [6 L]

3. Business Models of e – commerce: Model Based on Transaction Type, Model Based on Transaction Party - B2B, B2C, C2B, C2C, E – Governance. [3 L]

4. E – strategy: Overview, Strategic Methods for developing E – commerce. [2 L]

5. Four C's: (Convergence, Collaborative Computing, Content Management & Call Center). Convergence: Technological Advances in Convergence – Types, Convergence and its implications, Convergence & Electronic Commerce. Collaborative Computing: Collaborative product development, contract as per CAD, Simultaneous Collaboration, Security. Content Management: Definition of content, Authoring Tools & Content Management, Content – Partnership, repositories, convergence, providers, Web Traffic & Traffic Management; Content Marketing. Call Center: Definition, Need, Tasks Handled, Mode of Operation, Equipment, Strength & Weaknesses of Call Center, Customer Premises Equipment (CPE). [6 L]

6. Supply Chain Management: E – logistics, Supply Chain Portal, Supply Chain Planning Tools (SCP Tools), Supply Chain Execution (SCE), SCE - Framework, Internet's effect on Supply Chain Power. [4 L]

7. E – Payment Mechanism: Payment through card system, E – Cheque, E – Cash, E – Payment Threats & Protections. [3 L]

8. E – Marketing :. Home –shopping, E-Marketing, Tele-marketing [2 L]

9. Electronic Data Interchange (EDI) : Meaning, Benefits, Concepts, Application, EDI Model, Protocols (UN EDI FACT / GTDI, ANSI X – 12), Data Encryption (DES / RSA). [4L]

10. Risk of E – Commerce : Overview, Security for E – Commerce, Security Standards, Firewall, Cryptography, Key Management, Password Systems, Digital certificates, Digital signatures. [4 L]

11. E-business service implementation & optimization: Introduction, Optimization of E-Business services, Real-world E-Business, Software & services for developing E-Business application. [4 L]

Reference:

1. E-Commerce, M.M. Oka, EPH
2. Kalakotia, Whinston: Frontiers of Electronic Commerce, Pearson Education.
3. Bhaskar Bharat : Electronic Commerce - Technologies & Applications. TMH
4. Loshin Pete, Murphy P.A. : Electronic Commerce , Jaico Publishing Housing.
5. Murthy : E – Commerce , Himalaya Publishing.
6. E – Commerce : Strategy Technologies & Applications, Tata McGraw Hill.
7. Global E-Commerce, J. Christopher & T.H.K. Clerk, University Press
8. Beginning E-Commerce, Reynolds, SPD
9. Krishnamurthy, E-Commerce Mgmt, Vikas

# JIS College of Engineering

(An Autonomous Institution)

Department of Computer Science and Engineering

Full Curriculum and Syllabus of B.Tech. in Computer Science and Engineering

Programme under Autonomous Framework

*1<sup>st</sup> to 8<sup>th</sup> Semester. September 2015 reprint following 5<sup>th</sup> BOS meeting dated 24.09.2015*

**Paper Name: CAD VLSI**

**Code: CS 703E**

**Contacts: 3L+1T**

**Credits: 4**

**Allotted hours: 42L**

**Pre-requisite:** Analog & Digital Circuits, Programming Language  
Module 1

Overall perspective of VLSI Design, the MOS switch and CMOS, MOS based logic design, the CMOS logic styles, Pass Transistors

Module 2

Introduction to Verilog HDL, Combinational logic Design, complex designs using multiplexers/demultiplexers, decoders, Memory elements: flip-flops, latches, registers. Sequential logic Design: Concepts and state diagrams.

Module 3

Finite State Machine Design, Logic procedure for FSM, Complexity, execution time. Examples of FSM

Module 4

VLSI Design Issues: Timing in Digital Circuits, Data Path Design: Realizations of Computational blocks, like adders, multipliers, Design of Control Path: Hardwired and Micro-controlled.

Books

1. Digital Integrated Circuit, Jan M. Rabaey, Anantha Chandrakasan, Borivoje Nikolic
2. Application Specific Integrated Circuits, Michael John Sebastian Smith, Addison Wesley
3. Principles of CMOS VLSI Design, Systems Perspective, Neil H. E. Weste and Kamran Eshraghian
4. Basic VLSI Design, Douglas A Pucknell and Kamran Eshraghian, Prentice Hall of India

HDL Chip Design: A Practical Guide for Designing, Synthesizing and Simulating ASICs and FPGAs Using VHDL or Verilog, Douglas J. Smith, Doone Publi

# JIS College of Engineering

(An Autonomous Institution)

Department of Computer Science and Engineering

Full Curriculum and Syllabus of B.Tech. in Computer Science and Engineering

Programme under Autonomous Framework

1<sup>st</sup> to 8<sup>th</sup> Semester. September 2015 reprint following 5<sup>th</sup> BOS meeting dated 24.09.2015

## Elective II

**Paper Name: Natural Language Processing**

**Code: CS 704A**

**Contacts: 3L+1T**

**Credits: 4**

**Allotted hours: 42L**

### **Module 1: Overview & Introduction [4L]**

What are Natural language processing, origins of NLP, challenges of NLP, Language and grammar, NLP applications.

### **Module 2: Language Modeling [3L]**

Introduction, various grammar based language models, Statistical language model

### **Module 3: Word level analysis [5L]**

Introduction, Regular expressions, Finite state automata, morphological parsing, spelling error detection and correction, Words and word classes, Part-of-Speech tagging

### **Module 4: Syntactic Analysis [3L]**

Introduction, Context Free Grammar, Parsing, Probabilistic Parsing.

### **Module 5: Semantic Analysis [4L]**

Introduction, Meaning representation, Lexical semantics, ambiguity, Word sense disambiguation.

### **Module 6: Discourse processing [4L]**

Introduction, Cohesion, Reference resolution, discourse coherence and structure

### **Module 7: Natural language generation [4L]**

Introduction, architectures of NLG systems, generation tasks and representations, application of NLG

### **Module 8: Machine Translation [6L]**

Introduction, Problems in Machine translation, characteristics of Indian Languages, Machine translation approaches, Direct machine translation, Rule based machine translation, corpus based machine translation

### **Module 9: Information Retrieval [5L]**

Introduction, Design features of information retrieval systems, Information Retrieval Models, Classical information retrieval models, NLP in IR, Relation matching, Knowledge-based approaches

### **Module 10: Lexical Resources [4L]**

Introduction, WordNet, FrameNet, Stemmers, POS Tagger, Research Corpus

### **References:-**

1. Ruslan Mitkov, The Oxford Handbook Of Computational Linguistics, Oxford University Press, 2003.
2. Daniel Jurafsky, James Martin, Speech and Language Processing, Prentice Hall,
3. Robert Dale, Hermani Moisi, Harold Somers, Handbook Of Natural Language Processing, Markcel Dekker Inc.
4. James Allen, Natural Language Processing, Pearson Education, 2003.
5. Christopher D. Manning & Henrich Schutze, Foundations Of Statistical Natural Language Processing, The MIT Press, 2001
6. Douglas Biber, Susan Conrad, Randi Reppen, Corpus Linguistics – Investigating Language Structure And Use, Cambridge University Press, 2000.
7. David Singleton, Language And The Lexicon: An Introduction, Arnold Publishers, 2000.
8. Andrew Radford, Minimalist Syntax: Exploring The Structure Of English, Cambridge University Press, 2004.

**Paper Name: Distributed DBMS**



# JIS College of Engineering

(An Autonomous Institution)

Department of Computer Science and Engineering

Full Curriculum and Syllabus of B.Tech. in Computer Science and Engineering

Programme under Autonomous Framework

*1<sup>st</sup> to 8<sup>th</sup> Semester. September 2015 reprint following 5<sup>th</sup> BOS meeting dated 24.09.2015*

**Code: CS 704B**

**Contacts: 3L+1T**

**Credits: 4**

**Allotted hours: 42L**

Module I [5L]

Distributed DBMS features and needs. Reference architecture. Levels of distribution transparency, replication. Distributed database design - fragmentation, allocation criteria.

Module II [10L]

Storage mechanisms. Translation of global queries. / Global query optimisation. Query execution and access plan.

Concurrency control - 2 phases locks. Distributed deadlocks. Time based and quorum based protocols. Comparison.

Reliability- non-blocking commitment protocols.

Module III [10L]

Partitioned networks. Checkpoints and cold starts. Management of distributed transactions- 2 phase unit protocols.

Architectural aspects. Node and link failure recoveries.

Module IV [10L]

Distributed data dictionary management. Distributed database administration. Heterogeneous databases- federated

database, reference architecture, loosely and tightly coupled.

Module V [10L]

Alternative architecture. Development tasks, Operation- global task management. Client server databases- SQL server, open database connectivity. Constructing an application.

Books:

1. Database System Concepts, Silberschatz Korth, Sudarshan, MH
2. Distributed Database, Tannenbaum, Pearson
3. Principles of Distributed Database Systems, M. Tamerzsu Patrick Valduriez, Pearson
4. Distributed Databases Principles & Systems, Stefano Ceri and Giuseppe Pelagatti.

# JIS College of Engineering

(An Autonomous Institution)

Department of Computer Science and Engineering

Full Curriculum and Syllabus of B.Tech. in Computer Science and Engineering

Programme under Autonomous Framework

*1<sup>st</sup> to 8<sup>th</sup> Semester. September 2015 reprint following 5<sup>th</sup> BOS meeting dated 24.09.2015*

**Paper Name: Robotics**

**Code: CS 704C**

**Contacts: 3L+1T**

**Credits: 4**

**Allotted hours: 42L**

## UNIT I

15L

Introduction to cognitive science and perception, problem representation through heuristics, problem reduction, basic heuristic search procedures; Knowledge representation and knowledge engineering; Inference engines and expert systems; Programming languages for AI; Image recognition and computer vision; Speech recognition; Specifications of Robots-Classifications of robots –Work envelope -Flexible automation versus Robotic technology –Applications of Robots

## UNIT II

10L

Positions, Orientations and frames, Mappings: Changing descriptions from frame to frame, Operators: Translations, Rotations and Transformations –Transformation Arithmetic -D-H Representation - Robot arm geometry, forward and inverse kinematics problem, arm dynamics, D'Alembert's equation of motion, trajectory planning, and avoidance of obstacles, path planning, skew motion, joint integrated motion – straight line motion-Robot languages -.computer control and Robot software.

## UNIT III

15L

Introduction to mobile robotics, Sensing and perception building in robotics, brief overview of digital image processing, segmentation of images, Fuzzy-C-means clustering applied to image segmentation, Introduction to Neural Networks, multilayer perceptrons, back propagation learning, brief introduction to fuzzy set theory and fuzzy logic, fuzzy expert systems and rule based path planning of a mobile robot using back propagation neural networks (BPNN), fuzzy logic and Kalman filtering.

## UNIT III

5L

Introduction to genetic algorithms and application of GA in mobile robot path planning and navigation.

## TEXT

1. Deb S. R. and Deb S., "Robotics Technology and Flexible Automation", Tata McGraw Hill Education Pvt. Ltd, 2010.
2. Foo & Lee – Robotics, Control, Sensing, Vision & Intelligence [ McGraw Hill]
3. Mittal & Nagrath - Robotics & Control.(T M H)
4. Amit Konar – Computational Intelligence, Principles, Techniques and Applications
5. John J.Craig , "Introduction to Robotics", Pearson, 2009.
6. Mikell P. Groover et. al., "Industrial Robots -Technology, Programming and Applications" ;McGraw Hill, New York, 2008

## REFERENCE

1. Richard D Klafter, Thomas A Chmielewski, Michael Negin, "Robotics Engineering – An Integrated Approach", Eastern Economy Edition,Prentice Hall of India Pvt.Ltd., 2006
2. Fu K S, Gonzalez R C, Lee C.S.G, "Robotics : Control, Sensing, Vision and Intelligence"; McGraw Hill, 1987

# JIS College of Engineering

(An Autonomous Institution)

Department of Computer Science and Engineering

Full Curriculum and Syllabus of B.Tech. in Computer Science and Engineering

Programme under Autonomous Framework

*1<sup>st</sup> to 8<sup>th</sup> Semester. September 2015 reprint following 5<sup>th</sup> BOS meeting dated 24.09.2015*

**Paper Name: Internet Technology**

**Code: CS 704D**

**Contacts: 3L+1T**

**Credits: 4**

**Allotted hours: 42L**

## **Module I-22L**

Introduction (1L):

Overview, Network of Networks, Intranet, Extranet and Internet.

World Wide Web (1L):

Domain and Sub domain, Address Resolution, DNS, Telnet, FTP, HTTP.

Review of TCP/IP (1L):

Features, Segment, Three-Way Handshaking, Flow Control, Error Control, and Congestion control, IP Datagram, IPv4 and IPv6.

IP Subnetting and addressing (1L): Classful and Classless Addressing, Subnetting. NAT, IP masquerading, IP tables.

Internet Routing Protocol (1L): Routing -Intra and Inter Domain Routing, Unicast and Multicast Routing, Broadcast.

Electronic Mail (1L): POP3, SMTP.

Internet Protocol [6L]

Internet Architecture and Philosophy, The concept of unreliable delivery, Connectionless delivery system, The Internet Datagram, Routing direct and indirect delivery, Table driven IP routing, Protocol layering, Reliable stream transport, TCP performance, Bootstrap protocol (BOOTP).

Enterprise Networking [6L]

Corporate networking, Broadband at the Metropolitan area level, High speed dedicated WAN services and switched WAN services, ISDN, BISDN and ATM services, Frame relay technology and services, Virtual private network concepts PPTP protocol.

Internet Servers [4L]

DNS, DHCP Servers, FTP, TELNET, E-Mail

## **Module II-9L**

Image Maps (1L): map, area, attributes of image area.

CGI Scripts (1L): Introduction, Environment Variable, GET and POST Methods.

JavaScript (4L):

Basics, Statements, comments, variable, comparison, condition, switch, loop, break. Object – string, array, Boolean, reg-ex.

Function, Errors, Validation.

Cookies (1L): Definition of cookies, Create and Store a cookie with example.

Java Applets (2L): Container Class, Components, Applet Life Cycle, Update method; Parameter passing applet, Applications.

## **Module III-6L**

Client-Server programming In Java (2L): Java Socket, Java RMI.

Threats (1L): Malicious code-viruses, Trojan horses, worms; eavesdropping, spoofing, modification, denial of service attacks.

Network security techniques (2L): Password and Authentication; VPN, IP Security, security in electronic transaction, Secure Socket Layer(SSL), Secure Shell (SSH)

Firewall (1L):

Introduction, Packet filtering, Stateful, Application layer, Proxy.

## **Module IV-5L**

Internet Telephony (1L): Introduction, VoIP.

Multimedia Applications (2L): Multimedia over IP: RSVP, RTP, RTCP and RTSP. Streaming media, Codec and Plugins, IPTV.

Search Engine and Web Crawler (2L): Definition, Meta data, Web Crawler, Indexing, Page rank, overview of SEO.

# JIS College of Engineering

(An Autonomous Institution)

Department of Computer Science and Engineering

Full Curriculum and Syllabus of B.Tech. in Computer Science and Engineering

Programme under Autonomous Framework

*1<sup>st</sup> to 8<sup>th</sup> Semester. September 2015 reprint following 5<sup>th</sup> BOS meeting dated 24.09.2015*

**Paper Name: Artificial Intelligence**

**Code: CS 704E**

**Contacts: 3L+1T**

**Credits: 4**

**Allotted hours: 39L**

Overview of Artificial intelligence- Problems of AI, AI technique, Tic - Tac - Toe problem.

Intelligent Agents [2L]

Agents & environment, nature of environment, structure of agents, goal based agents, utility based agents, learning agents.

Problem Solving [2L]

Problems, Problem Space & search: Defining the problem as state space search, production system, problem characteristics, issues in the design of search programs.

Search techniques [5L]

Solving problems by searching :problem solving agents, searching for solutions; uniform search strategies: breadth first search, depth first search, depth limited search, bidirectional search, comparing uniform search strategies.

Heuristic search strategies [4L]

Greedy best-first search, A\* search, memory bounded heuristic search: local search algorithms & optimization problems: Hill climbing search, simulated annealing search, local beam search, genetic algorithms; constraint satisfaction problems, local search for constraint satisfaction problems.

Adversarial search [3L]

Games, optimal decisions & strategies in games, the minimax search procedure, alpha-beta pruning, additional refinements, iterative deepening.

Knowledge & reasoning [3L]

Knowledge representation issues, representation & mapping, approaches to knowledge representation, issues in knowledge representation.

Using predicate logic [2L]

Representing simple fact in logic, representing instant & ISA relationship, computable functions & predicates, resolution, natural deduction.

Representing knowledge using rules [3L]

Procedural verses declarative knowledge, logic programming, forward verses backward reasoning, matching, control knowledge.

Probabilistic reasoning [3L]

Representing knowledge in an uncertain domain, the semantics of Bayesian networks, Dempster-Shafer theory, Fuzzy sets & fuzzy logics.

Planning [2L]

Overview, components of a planning system, Goal stack planning, Hierarchical planning, other planning techniques.

Natural Language processing [2L]

Introduction, Syntactic processing, semantic analysis, discourse & pragmatic processing.

# **JIS College of Engineering**

(An Autonomous Institution)

Department of Computer Science and Engineering

Full Curriculum and Syllabus of B.Tech. in Computer Science and Engineering

Programme under Autonomous Framework

*1<sup>st</sup> to 8<sup>th</sup> Semester. September 2015 reprint following 5<sup>th</sup> BOS meeting dated 24.09.2015*

Learning [3L]

Forms of learning, inductive learning, learning decision trees, explanation based learning, learning using relevance information, neural net learning & genetic learning.

Expert Systems [2L]

Representing and using domain knowledge, expert system shells, knowledge acquisition.

Basic knowledge of programming language like Prolog & Lisp. [3L]

Books:

1. Artificial Intelligence, Ritch & Knight, TMH
2. Artificial Intelligence A Modern Approach, Stuart Russel Peter Norvig Pearson
3. Introduction to Artificial Intelligence & Expert Systems, Patterson, PHI
4. Poole, Computational Intelligence, OUP
5. Logic & Prolog Programming, Saroj Kaushik, New Age International
6. Expert Systems, Giarranto, VIKAS
7. Artificial Intelligence, Russel, Pearson

# JIS College of Engineering

(An Autonomous Institution)

Department of Computer Science and Engineering

Full Curriculum and Syllabus of B.Tech. in Computer Science and Engineering

Programme under Autonomous Framework

*1<sup>st</sup> to 8<sup>th</sup> Semester. September 2015 reprint following 5<sup>th</sup> BOS meeting dated 24.09.2015*

## Lab

**Paper Name: Compiler Design Lab**

**Code: CS 791**

**Contacts: 3P**

**Credits: 2**

1. NFA Construction from a regular expression.
2. Conversion between NFA and DFA.
3. Use LEX tool to implement a lexical analyzer.
4. Use YACC tool to implement a syntax analyzer or parser.
5. Implementation of a recursive descent parser for an expression grammar that generates arithmetic expressions with digits, + and \*.
6. Checking whether a string belongs to a grammar or not.
7. Calculation of leading & trailing for all the non-terminals of the given grammar.
8. Calculation of FIRST, FOLLOW of the given grammar.
9. Identifying whether a given string is a identifier or not.
10. Identifying whether a string is a keyword or not.
11. Identifying whether a string is a constant or not.

**Paper Name: Soft Computing Lab**

**Code: CS 792**

**Contacts: 3P**

**Credits: 2**

1. Python / Matlab programming introduction.
2. Matlab programming fundamental. / Python programming fundamental.
3. Matlab tool box implementation. / Python introduction to numerical calculation programming (scientific python, Numerical python, Image processing).
4. Python/Matlab programming to simulate a single layer neural network designs.
5. Python/Matlab programming to simulate multiple layer neural network designs.
6. Python/Matlab programming to observe the perceptron learning algorithm performances for a single layer network. In this experiment consider the XOR dataset.
7. Write a Matlab/python code for maximizing  $F(x)=x^2$ , where  $x$  ranges from say 0 to 31 using Genetic Algorithm.
8. Use of Genetic Algorithm toolbox in matlab for optimization problem solving. Implantation Simple Genetic Algorithm in python for solving optimization problem.
9. Write a Matlab/python program to implement the different Fuzzy Membership functions.
10. Write a Matlab/python program to implement Fuzzy set operations and its properties.

# **JIS College of Engineering**

(An Autonomous Institution)

Department of Computer Science and Engineering

Full Curriculum and Syllabus of B.Tech. in Computer Science and Engineering

Programme under Autonomous Framework

*1<sup>st</sup> to 8<sup>th</sup> Semester. September 2015 reprint following 5<sup>th</sup> BOS meeting dated 24.09.2015*

**Paper Name: Assigned Project**

**Code: CS 781**

**Contacts: 3P**

**Credits: 4**

1. Notification of Project and Domain Name
2. Group Submission
3. Supervisor Selection
4. Notification of Group List and Assigned Domain
5. Project Allocation
6. Project Evaluation by Execution
7. End Semester Examination through report and project presentation

**Paper Name: Seminar-I**

**Code: CS 782**

**Contacts: 3P**

**Credits: 2**

1. Notification of Presentation
2. Group Submission
3. Evaluation
4. End Semester Examination and presentation

**Paper Name: Practical Training Evaluation**

**Code: CS 783**

**Contacts: 3P**

**Credits: 2**

1. Notification of training
2. Applying for training
3. Joining the training Program
4. End Semester Examination through report / presentation

# **JIS College of Engineering**

(An Autonomous Institution)

Department of Computer Science and Engineering

Full Curriculum and Syllabus of B.Tech. in Computer Science and Engineering

Programme under Autonomous Framework

*1<sup>st</sup> to 8<sup>th</sup> Semester. September 2015 reprint following 5<sup>th</sup> BOS meeting dated 24.09.2015*



# JIS College of Engineering

(An Autonomous Institution)

Department of Computer Science and Engineering

Full Curriculum and Syllabus of B.Tech. in Computer Science and Engineering

Programme under Autonomous Framework

1<sup>st</sup> to 8<sup>th</sup> Semester. September 2015 reprint following 5<sup>th</sup> BOS meeting dated 24.09.2015

## 8<sup>th</sup> Semester

A. Theory							
Sl. No.	Paper Code	Paper Name	Contact hours/week				Credit points
			L	T	P	Total	
1	HU 801	Financial Management	3	1	0	4	4
2	CS 801	Elective III A. Network Security B. VLSI Design C. Data Warehousing & Data Mining D. Ad-hoc Networking	3	1	0	4	4
3	CS 802	Elective IV A. Cryptography B. Pattern Recognition C. Image Processing D. Internet Security	3	1	0	4	4
<b>Total of Theory</b>			<b>12</b>				<b>12</b>
B. Practical							
Sl. No.	Paper Code	Paper Name	Contact hours/week				Credit points
			L	T	P	Total	
1	CS 881	Assigned Project(Cont.)	0	0	3	3	8
2	CS 882	Seminar II	0	0	3	3	2
3	CS 883	Grand Viva	0	0	3	3	2
<b>Total of Practical</b>			<b>9</b>				<b>12</b>
<b>Total of Semester</b>			<b>21</b>				<b>24</b>

# JIS College of Engineering

(An Autonomous Institution)

Department of Computer Science and Engineering

Full Curriculum and Syllabus of B.Tech. in Computer Science and Engineering

Programme under Autonomous Framework

1<sup>st</sup> to 8<sup>th</sup> Semester. September 2015 reprint following 5<sup>th</sup> BOS meeting dated 24.09.2015

## 8<sup>th</sup> Semester

**Paper Name: Financial Management**

**Code: HU 801**

**Contacts: 3L+1T**

**Credits: 4**

**Allotted hours: 42L**

Unit 1

Introduction to Accounting

- a) Important Definitions
- b) Basic concepts and conventions
- c) Types of Accounts with Golden Rule of Accounting
- d) Journal, Ledger and Trial Balance
- e) Preparation of Trading Account, Profit & Loss A/C and Balance Sheet for business organisations.

Unit 2

Financial Management

Financial Management: Basic Concepts

Meaning and Definition of financial management

Functions of Financial Management

Risk and Return: introduction

Return, Investment, Risk.

Risk-Return Relationship

Ratio Analysis: Definition, Objectives, Advantages & Disadvantages.

Classification of Ratios: Liquidity ratios, Capital Structure ratios, Activity ratios & Profitability Ratios

Unit-3

Cost of capital: Definition, Objectives, various models for calculations of different kind of cost of capital such as Equity capital, Preference Capital, Debt-Capital, Overall cost of capital or average cost of capital.

Capital Budgeting:

Nature of Investment Decision, Importance of Capital Budgeting, capital budgeting process, Investment criteria, payback period, Rate of return, cash flow, discounting cash flow, NPV method and IRR method.

Unit 4

Cost Accounting

- a) Introduction to cost accounting
- b) Statement of cost or cost sheet
- c) Marginal cost & C-V-P analysis with BEC.

Budget and Budgetary Control

Concepts of Budget, Budgeting and budgetary control, advantages, disadvantages, uses, Master Budget, Zero Based Budget, types of budgets.

Reference books:

Financial Management, Khan & Jain, S.Chand

Management Accounting, Khan & Jain, S.Chand

Modern Accountancy, Haniff & Mukherjee, TMH

An Introduction to Accountancy, S.N.Maheswari, Vikas publication

Cost Accounting: Theory and Practices, B.Banerjee, PHI

Financial Management, IM Pandey, Vikas

# JIS College of Engineering

(An Autonomous Institution)

Department of Computer Science and Engineering

Full Curriculum and Syllabus of B.Tech. in Computer Science and Engineering

Programme under Autonomous Framework

*1<sup>st</sup> to 8<sup>th</sup> Semester. September 2015 reprint following 5<sup>th</sup> BOS meeting dated 24.09.2015*

## Elective III

**Paper Name: Network Security**

**Code: CS 801A**

**Contacts: 3L+1T**

**Credits: 4**

**Allotted hours: 42L**

### MODULE I: FUNDAMENTALS (10L)

Attacks, Services and Mechanisms, Security Attacks, Security Services, Integrity check, digital Signature, authentication, OSI security architecture, Classical encryption techniques, Cipher principles, Data encryption standard (DES), Block cipher design principles and modes of operation, Evaluation criteria for AES, AES cipher, Triple DES, ECB, CBC, OFB, CFB.

### MODULE II: PUBLIC KEY CRYPTOGRAPHY (8L)

Algorithms, examples, RSA: generating keys, encryption and decryption. Diffie-Hellman.

### MODULE III: AUTHENTICATION AND HASH FUNCTION (10L)

Authentication requirements, Authentication functions, Message authentication codes, Hash functions, Security of hash functions and MACS, MD5 Message Digest algorithm, Secure hash algorithm, Ripend, HMAC digital signatures, Authentication protocols, Digital signature standard.

### MODULE IV: NETWORK SECURITY (6L)

Authentication applications, Kerberos, Electronic mail security, S/MIME, IP security, Web security, Security for electronic commerce: SSL, SET.

### MODULE V: SYSTEM LEVEL SECURITY (8L)

Intrusion detection, Password management, Viruses and related threats, Virus counter measures, Firewall design principles, Trusted systems.

Books:

1. Atul Kahate, Cryptography and Network Security, McGraw Hill.
2. Kaufman, C., Perlman, R., and Speciner, M., Network Security, Private Communication in a public world, 2nd ed., Prentice Hall
3. Stallings, W., Cryptography and Network Security: Principles and Practice, 3rd ed., Prentice Hall
4. Stallings, W. Network security Essentials: Applications and standards, Prentice Hall
5. Cryptography and Network Security; McGraw Hill; Behrouz A Forouzan.

# JIS College of Engineering

(An Autonomous Institution)

Department of Computer Science and Engineering

Full Curriculum and Syllabus of B.Tech. in Computer Science and Engineering

Programme under Autonomous Framework

*1<sup>st</sup> to 8<sup>th</sup> Semester. September 2015 reprint following 5<sup>th</sup> BOS meeting dated 24.09.2015*

**Paper Name: VLSI Design**

**Code: CS 801B**

**Contacts: 3L+1T**

**Credits: 4**

**Allotted hours: 39L**

Note: Trace on Basic concepts only

Introduction to CMOS circuits: MOS Transistors, MOS transistor switches, CMOS Logic, The inverter, Combinational Logic, NAND gate, NOT Gate, Compound Gates, Multiplexers, Memory-Latches and Registers. [6L]

Processing Technology: Silicon Semiconductor Technology- An Overview, wafer processing, oxidation, epitaxy deposition, Ion-implantation and diffusion, The Silicon Gate Process- Basic CMOS Technology, basic n-well CMOS process, p-well CMOS process, Twin tub process, Silicon on insulator, CMOS process enhancement-Interconnect, circuit elements, 3-D CMOS. Layout Design Rule: Layer Representations, CMOS n-well Rules, Design Rule of background scribe line, Layer Assignment, SOI Rule [10L]

Power Dissipation: Static dissipation, Dynamic dissipation, short-circuit dissipation, total power dissipation. Programmable Logic, Programmable Logic structure, Programmable interconnect, and Reconfigurable Gate Array: Xilinx Programmable Gate Array, Design Methods: Behavioural Synthesis, RTL synthesis [8L]

Placement: placement: Mincut based placement – Iterative improvement placement simulated annealing.

Routing: Segmented channel routing – maze routing – routability and routing resources – net delays. [5L]

Verification and Testing: Verification Versus Testing, Verification: logic simulation design validation – timing verification – Testing concepts: failures – mechanisms and faults – fault coverage – ATPG methods – types of tests – FPGAs – programmability failures – design for testability. [5L]

Overview of VHDL [5L]

Text Book:

1. “Digital Integrated Circuit”, J.M.Rabaey, Chandrasan, Nicolic, Pearson

2. “CMOS Digital Integrated Circuit”, S.M.Kang & Y.Leblebici, TMH

3. “Modern VLSI Design” Wayne Wolf, Pearson

4. “Algorithm for VLSI Design & Automation”, N.Sherwani, Kluwer

5. “VHDL”, Bhaskar, PHI

References:

1. “ Digital Integrated Circuits” Demassa & Ciccone, Willey Pub.

2. “Modern VLSI Design: system on silicon” Wayne Wolf; Addison Wesley Longman Publisher

3. “Basic VLSI Design” Douglas A. Pucknell & Kamran Eshraghian; PHI

4. “CMOS Circuit Design, Layout & Simulation”, R.J.Baker, H.W.Lee, D.E. Boyee, PHI

# JIS College of Engineering

(An Autonomous Institution)

Department of Computer Science and Engineering

Full Curriculum and Syllabus of B.Tech. in Computer Science and Engineering

Programme under Autonomous Framework

*1<sup>st</sup> to 8<sup>th</sup> Semester. September 2015 reprint following 5<sup>th</sup> BOS meeting dated 24.09.2015*

**Paper Name: Data Warehousing & Data Mining**

**Code: CS 801C**

**Contacts: 3L+1T**

**Credits: 4**

**Allotted hours: 41L**

## **Module 1: Introduction to Data Mining [6L]**

What is data mining? Related technologies - Machine Learning, Statistics, Data Mining Goals, Stages of the Data Mining Process, Data Mining Techniques, Knowledge Representation Methods, role of meta data, Applications.

## **Module 2: Data pre-processing [3L]**

Data cleansing, data transformation, Overview of ETL, Requirements of ETL, data reduction, discretization and generating concept hierarchies.

## **Module 3: Data mining algorithms: Association rules [3L]**

Motivation and terminology, Example: mining weather data, Basic idea: item sets, Generating item sets and rules efficiently, Correlation analysis.

## **Module 4: Data mining algorithms: Classification [5L]**

Basic learning/mining tasks, Inferring rudimentary rules: 1R algorithm, Decision tree learning, Tree pruning methods, Covering rules, Instance based learning, Bayesian learning.

## **Module 5: Data mining algorithms: Prediction [5L]**

The prediction task, Statistical (Bayesian) classification, Bayesian networks, Instance-based methods (nearest neighbour), Linear models.

## **Module 6: Clustering [6L]**

Basic issues in clustering, Partitioning methods: k-means, Expectation maximization (EM), Hierarchical methods: distance-based agglomerative and divisible clustering, semi-supervised and active learning, Case study for classification learning: KDD Cup.

## **Module 7: Data Warehousing [6L]**

Data Warehouse and data marts, Architecture of a data warehouse, Centralized, Independent data marts, Federated, Hub-and-Spoke, Differences between Online Transaction Processing (OLTP) and Online Analytical Processing (OLAP), Multidimensional data model, Data cubes, Familiarity with OLAP models – Overview of variations, MOLAP, ROLAP, HOLAP, DOLAP, OLAP operations, Enterprise OLAP, Web-OLAP approaches, OLAP Engine design, Algorithms for data cube computation, index structures for data warehousing.

## **Module 8: Advanced Techniques & Application [7L]**

Text mining: extracting attributes (keywords), Structural approaches (parsing, soft parsing). Bayesian approach to classifying text.

Web mining: classifying web pages, extracting knowledge from the web.

Data Mining Applications in industry – Benefits of Data mining, Discussion on applications in Customer Relationship Management (CRM), Retail, Telecommunication, Biotechnology, Banking etc.

## **References:-**

1. Data Warehousing Fundamentals for IT Professionals, Second Edition by Paulraj Ponniah, Wiley India
2. Data Warehousing, Data Mining, & OLAP – Second Edition by Alex Berson and Stephen J. Smith, Tata McGraw Hill Education

# JIS College of Engineering

(An Autonomous Institution)

Department of Computer Science and Engineering

Full Curriculum and Syllabus of B.Tech. in Computer Science and Engineering

Programme under Autonomous Framework

*1<sup>st</sup> to 8<sup>th</sup> Semester. September 2015 reprint following 5<sup>th</sup> BOS meeting dated 24.09.2015*

3. Data warehouse Toolkit by Ralph Kimball, Wiley India

**Paper Name: Ad-hoc Networking**

**Code: CS 801D**

**Contacts: 3L+1T**

**Credits: 4**

**Allotted hours: 42L**

## **INTRODUCTION & MAC PROTOCOLS [8L]**

Introduction to adhoc networks – definition, characteristics features, applications. Characteristics of Wireless channel, Adhoc Mobility Models:- Indoor and out door models.

## **ROUTING PROTOCOLS [9L]**

Classifications, Table Driven, On-Demand, Hybrid and Hierarchical Routing Protocols, Routing Protocols with efficient Flooding mechanism, Power aware Routing Protocols. Operation of Multicast Routing Protocols, Energy efficient Multicasting and Multicasting with QoS guarantees.

## **TRANSPORT LAYER AND SECURITY PROTOCOLS [9L]**

Introduction, Issues, Design Goals, Classification of Transport Layer Solutions, TCP over Ad Hoc Wireless Networks, Other Transport Layer Protocols, Security in Ad Hoc Wireless Networks, Secure Routing in Ad Hoc wireless Networks.

## **QOS [8L]**

Introduction, Issues and Challenges, Classifications of QoS Solutions, MAC Layer Solutions, Network Layer Solutions, QoS Frameworks for Ad Hoc Wireless Networks

## **ENERGY MANAGEMENT [8L]**

Introduction, Need for Energy Management, Classification of Energy Management Schemes, Battery Management Schemes, Transmission Power Management Schemes, System Power Management Schemes

## **TEXT BOOK**

Siva Ram Murthy C, Manoj B.S, Ad Hoc Wireless Networks: Architectures and Protocols, Prentice Hall, 2005.

## **REFERENCES**

Chai-Keong Toh, Ad HOC Mobile Wireless Networks, PHI, 2002.

Charles Perkins, Ad Hoc Networking, Addison Wesley, 2001.

Mohammed Liyas, Handbook of Ad Hoc Wireless Networks, CRC Press, 2003.

# JIS College of Engineering

(An Autonomous Institution)

Department of Computer Science and Engineering

Full Curriculum and Syllabus of B.Tech. in Computer Science and Engineering

Programme under Autonomous Framework

*1<sup>st</sup> to 8<sup>th</sup> Semester. September 2015 reprint following 5<sup>th</sup> BOS meeting dated 24.09.2015*

## Elective IV

**Paper Name: Cryptography**

**Code: CS 802A**

**Contacts: 3L+1T**

**Credits: 4**

**Allotted hours: 34L**

**Module 1: Introduction**, practical cryptography overview: stream ciphers, block ciphers, hash functions (2L)

**Module 2: Public-Key Cryptography** and RSA, Principles of Public-Key Cryptosystems, the RSA Algorithm, Public-Key Encryption and Hash Functions, Introduction to Number Theory, Prime Numbers Fermat's and Euler's Theorems, Testing for Primality, the Chinese Remainder Theorem, Discrete Logarithms (7L)

**Module 3: Block Ciphers and the Data Encryption Standard** , Block Cipher Principles, The Data Encryption Standard , The Strength of DES, Differential and Linear Cryptanalysis , Block Cipher Design Principles (7L)

**Module 4: Advanced Encryption Standard** , Evaluation Criteria For AES, The AES Cipher (2L)

**Module 5: Symmetric Ciphers**, Classical Encryption Techniques, Symmetric Cipher Model, Substitution Techniques, Transposition Techniques, Rotor Machines, Steganography, More on Symmetric Ciphers , Multiple Encryption and Triple DES, Block Cipher Modes of Operation , Stream Ciphers and RC4 (8L)

**Module 6:** Placement of Encryption Function, Traffic Confidentiality, Key Distribution, Random Number Generation (3L)

**Module 7:** Key Management; Other Public-Key Cryptosystems, Key Management, Diffie-Hellman Key Exchange, Elliptic Curve Arithmetic, Elliptic Curve Cryptography (3L)

**Module 8:** Hash and MAC Algorithms, Secure Hash Algorithm, Whirlpool, HMAC, CMAC (2L)

### **Books:**

1. Atul Kahate, Cryptography and Network Security, McGraw Hill.
2. Kaufman, C., Perlman, R., and Speciner, M., Network Security, Private Communication in a public world, 2nd ed., Prentice Hall
3. Stallings, W., Cryptography and Network Security: Principles and Practice, 3rd ed., Prentice Hall
4. Stallings, W. Network security Essentials: Applications and standards, Prentice Hall
5. Cryptography and Network Security; McGraw Hill; Behrouz A Forouzan.

# JIS College of Engineering

(An Autonomous Institution)

Department of Computer Science and Engineering

Full Curriculum and Syllabus of B.Tech. in Computer Science and Engineering

Programme under Autonomous Framework

*1<sup>st</sup> to 8<sup>th</sup> Semester. September 2015 reprint following 5<sup>th</sup> BOS meeting dated 24.09.2015*

**Paper Name: Pattern Recognition**

**Code: CS 802B**

**Contacts: 3L+1T**

**Credits: 4**

**Allotted hours: 42L**

Module – I

Basics of pattern recognition Features, Feature Vectors and Classifiers, Supervised versus Unsupervised Pattern Recognition, Comparison of Supervised and unsupervised Pattern Recognition

Module - II

Feature extraction, Different approaches to Feature Selection, Nearest Neighbour, Classifier and variants Efficient algorithms for nearest neighbor classification

Module - III

Different Approaches to Prototype Selection Bayes Classifier Decision Trees Linear Discriminant Function parameter estimation methods, Maximum Likelihood estimation, Gaussian mixture models

Module - IV

**Component analyses** : Principal component analysis, non-linear component analysis; Support Vector Machines Clustering Clustering Large datasets Combination of Classifiers Applications – Document Recognition

REFERENCES

1. R. O. Duda, P. E. Hart and D. G. Stork, Pattern Classification, Wiley, 2000.
2. V.Vapnik, Statistical Learning Theory, John Wiley & Sons, 1998
3. R.Herbrich, Learning Kernel Classifiers – Theory and Algorithms, The MIT Press, 2002
4. C.M.Bishop, Pattern Recognition and Machine Learning, Cambridge University Press, 2006
5. G.Camps-Valls, J.L. Rojo-Alvarez and M.Martinez-Ramon (Eds.), Kernel Methods in Bioengineering, Signal and Image Processing, Idea Group Publishing, 2007
6. B.Scholkopf, K.Tsuda and J-P. Vert (Eds.), Kernel Methods in Computational Biology, The MIT Press, 2004.
7. Devi V.S.; Murty, M.N. (2011) Pattern Recognition: An Introduction, Universities Press, Hyderabad.



# JIS College of Engineering

(An Autonomous Institution)

Department of Computer Science and Engineering

Full Curriculum and Syllabus of B.Tech. in Computer Science and Engineering

Programme under Autonomous Framework

*1<sup>st</sup> to 8<sup>th</sup> Semester. September 2015 reprint following 5<sup>th</sup> BOS meeting dated 24.09.2015*

**Paper Name: Image Processing**

**Code: CS 802C**

**Contacts: 3L+1T**

**Credits: 4**

**Allotted hours: 42L**

**Introduction:** Application domain of digital image processing, fundamental steps in digital image processing, components of image processing system.

**Digital Image Fundamentals:** A simple image formation model, image sampling, and quantization, basic relationships between pixels.

**Image enhancement (Spatial domain):** Basic gray-level transformation, histogram processing, enhancement using arithmetic and logic operators, basic spatial filtering, smoothing and sharpening spatial filters, combining the spatial enhancement methods.

**Image restoration:** A model of the image degradation/restoration process, noise models, restoration in the presence of noise—only spatial filtering, Weiner filtering, constrained least squares filtering, geometric transforms; Introduction to the Fourier transform and the frequency domain, estimating the degradation function.

**Color Image Processing:** Color fundamentals, color models, pseudo color image processing, basics of full-color image processing, color transforms, smoothing and sharpening, color segmentation.

**Image Compression:** Fundamentals, image compression models, error-free compression, lossy predictive coding, image compression standards.

**Morphological Image Processing:** Preliminaries, dilation, erosion, open and closing, hit or miss transformation, basic morphologic algorithms.

**Image Segmentation:** Detection of discontinuous, edge linking and boundary detection, thresholding, region-based segmentation.

## TEXT BOOKS:

**Digital Image Processing**, Rafeal C.Gonzalez, Richard E.Woods, Second Edition, Pearson Education/PHI.

## REFERENCE BOOKS:

**Image Processing, Analysis, and Machine Vision**, Milan Sonka, Vaclav Hlavac and Roger Boyle, Second Edition, Thomson Learning.

# JIS College of Engineering

(An Autonomous Institution)

Department of Computer Science and Engineering

Full Curriculum and Syllabus of B.Tech. in Computer Science and Engineering

Programme under Autonomous Framework

*1<sup>st</sup> to 8<sup>th</sup> Semester. September 2015 reprint following 5<sup>th</sup> BOS meeting dated 24.09.2015*

**Paper Name: Internet Security**

**Code: CS 802D**

**Contacts: 3L+1T**

**Credits: 4**

**Allotted hours: 42L**

## **Module I:**

1) Introduction

Why require a security Picking a Security Policy , Strategies for a Secure Network, The Ethics of Computer Security, Security Threats and levels, Security Plan (RFC 2196)

## **Module II :**

2) Classes of Attack Stealing Passwords. Social Engineering. Bugs and Backdoors. Authentication Failures. Protocol Failures. Information Leakage. Exponential Attacks? Viruses and Worms. Denial-of-Service Attacks.

Computer Security What are viruses, Trojan Horse, Worms How to protect the computer against virus What is the Structure of virus?

## **Module III**

Firewalls and Proxy Servers Kinds of Firewalls. Packet Filters. Application-Level Filtering. Circuit-Level Gateways. Dynamic Packet Filters. Distributed Firewalls.

What Firewalls Cannot Do Filtering Services. Reasonable Services to Filter. Digging for Worms. Packet Filtering Implementing policies (Default allow , Default Deny ) on proxy

## **Module IV**

Cryptography Introduction to Basic encryption and Decryption, Diffie ? Hellman Key Exchange Concept of Public key and Private key Digital Signatures

## **Books:**

1. "Security Deficit Comprehensive Internet Security Strategy" ,Pentagon Press
2. "Implementing Biometric Security (Wiley red Books)"- John chirilles, Scott Blaul

# **JIS College of Engineering**

(An Autonomous Institution)

Department of Computer Science and Engineering

Full Curriculum and Syllabus of B.Tech. in Computer Science and Engineering

Programme under Autonomous Framework

*1<sup>st</sup> to 8<sup>th</sup> Semester. September 2015 reprint following 5<sup>th</sup> BOS meeting dated 24.09.2015*

**Paper Name: Assigned Project (Cont.)**

**Code: CS 881**

**Contacts: 3P**

**Credits: 8**

1. Project Evaluation by Execution
2. End Semester Examination through report and project presentation

**Paper Name: Seminar-II**

**Code: CS 882**

**Contacts: 3P**

**Credits: 2**

1. Notification of Presentation
2. Group Submission
3. Evaluation
4. End Semester Examination and presentation

**Paper Name: Grand Viva**

**Code: CS 883**

**Contacts: 3P**

**Credits: 2**

1. Notification of Examination Date
2. End Semester Examination through report / presentation

# JIS College of Engineering

(An Autonomous Institution)

Department of Computer Science and Engineering

Full Curriculum and Syllabus of B.Tech. in Computer Science and Engineering

Programme under Autonomous Framework

1<sup>st</sup> to 8<sup>th</sup> Semester. September 2015 repint following 5<sup>th</sup> BOS meeting dated 24.09.2015

## Credit Details

	Subject	Credit Range								Total Credit
		1st	2nd	3rd	4th	5th	6th	7th	8th	
1.	Humanities And Social Science including Management (Hs)	4				2	3	3	4	16
2.	Basic Science Including Physics, Chemistry, Maths, Biology (Bs)	9	9	8	5					31
3.	Engineering Science Including Workshop, Drawing, Basics Of EE/ECE/ME/Computer (Es)	10	10	3	12					35
4.	Professional Subject Core (Pc)	5	8	12	9	26	24	12	0	96
5.	Elective Subjects							8	8	16
6.	Open Electives									
7.	Project Work, Seminar			2			2	8	12	24
8	NCC/NSS	1								1

# **JIS College of Engineering**

(An Autonomous Institution)

Department of Computer Science and Engineering

Full Curriculum and Syllabus of B.Tech. in Computer Science and Engineering

Programme under Autonomous Framework

*1<sup>st</sup> to 8<sup>th</sup> Semester. September 2015 reprint following 5<sup>th</sup> BOS meeting dated 24.09.2015*

<b>Total</b>	219
--------------	-----