

## **Energy conservation program**

Energy conservation refers to the methods of reduction in energy consumption by way of elimination of wastage and promotion of efficiency. We know that due to the vast gap between demand and supply, lot of efforts is being done to bridge the gap in terms of generation of more electricity which requires lot of capital investment and apart from it creates lot of environmental concerns. Energy conservation is the key element of energy management. We can reduce the energy consumption by adopting various ways of energy conservation which includes efficient use of technologies and avoiding energy wastages.

This is despite the fact that energy saving initiatives can reduce revenue expenditure over the whole organization with very low capital investment requirements and can continue to do so over a very long period. Among the reasons given for this has been shortage of capital to invest and short-term company policies and it has been difficult for energy managers to gain the necessary support for energy saving projects. The following are some of the initiatives in JISCE campus to save energy.

### **1. Solar power generation:**

20 nos. of solar panels are there in the campus which generate 0.8w<sub>p</sub>/ panel and the total generation of power per day is 5kwh.



## **Solar panels**

### **2. Solar Tree:**

There are 2 nos of solar trees are set at the entrance of the JISCE college where 18 solar panels are used generating the power of 2700wh per day.



**Solar tree**

### **3. Solar street light:**

7 nos. street lights are there around the campus using 1 solar panel for each lamp post. These panels are generating 500 wh power per day.



**Solar Street Light**

#### **4. ECONOMIC CLASS GENERALIZED HANDICAPPED VEHICLE FOR UPPER AND LOWER AMPUTEE PATIENTS:**

Economic Class Generalized Handicapped Vehicle (ECGHV) for Upper and Lower Amputee Patients is an innovatively designed low cost vehicle for handicapped, cerebral palsy patients and senior citizens. The handicapped vehicle emphasizes on the focal points by ensuring user-friendly distinctiveness for physically challenged people and affordable characteristics for availability to all strata of people in the society. The novelty of the designed vehicle lies in its effortless simplicity and indisputable intention, accentuating the underlying societal impact. The requisite for handicapped vehicle is indispensable for social, economic and operational emancipation of disabled personage.

A handicapped individual does not have to paddle the vehicle to traverse a protracted distance. Instead the ride would be an effortless and comfortable one, to say the least. Comfort echelon is optimum as there is a roof of the vehicle which would shield the individual from sunlight, rain and other natural predicament at bay.

Powered by an electric motor running on batteries, the modus operandi is posite for a handicapped individual to traverse en route. In apiece battery charge, the vehicle could run for 80 kilometres at a speed of 15–20 kilometre/hour. The vehicle could be employed to carry goods from one place to another, as well. The said vehicle is cheap, simple and low maintenance vehicle. Eight models are designed for diverse upper and lower amputee handicapped patients having skeletal impairments, arthritis, cerebral palsy (cp), spinal cord injury, head injury (cerebral trauma), stroke (cerebral vascular accident - cva), loss of limbs or digits (amputation or congenital), Parkinson's disease, multiple sclerosis (ms), ALS (Lou Gehrig's disease), muscular dystrophy (md).

**Current Status:** Ongoing Successfully, Marketable, Patent filing done. Order of about 25 pieces has been received from NGOs. Leading Battery Company "EXIDE" wants to tie-up to sponsor the tires of the vehicle.

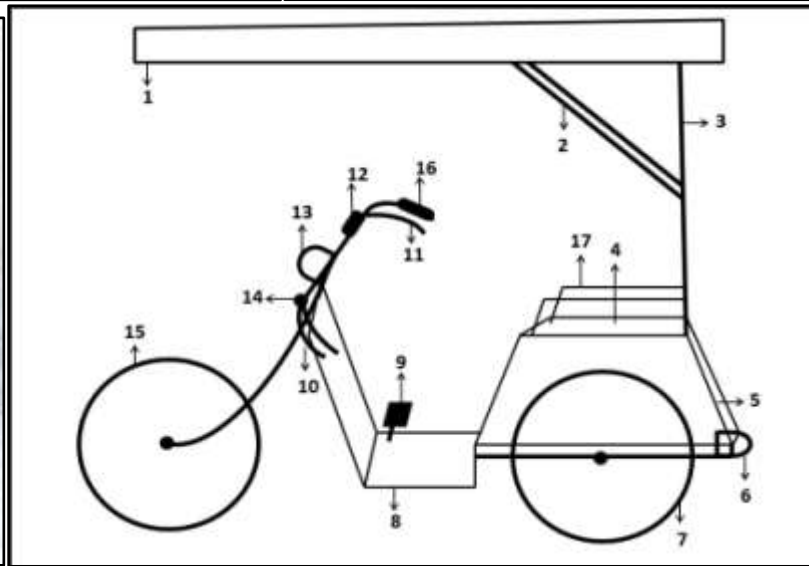

Eco friendly Van



# “Embrace the Green Revolution”

Report on Making JISCE, Kalyani Campus Green

We live today in an era of surplus in which consumer products flood the shelves, while the natural world around us is being depleted. Sustainable development refers to rational use of natural resources so as to preserve the planet as a life supporting habitat for future generations. Many complex environmental issues that relate to sustainability are at the center of the academic and social agenda.

Sustainability is a philosophy of life and a way of life that strives to enable everyone access to environmental, social and economic resources yet defends the rights of future generations as well. Every society has its special concept of sustainability linked to its traditions and environment. Therefore every group may enrich the ideas and activities of others. “Campus Greening“ is a concept which stands for the efforts to establish environmentally sustainable practices in educational institutions the world over. Its goal is to diminish the impact of ecological footprints by implementing the principles of sustainability at every level of institutional functioning.

**The Environment and Education Club, JISCE**, contributed, towards a green campus in its own unique way throughout the whole year.

World Environment Day is celebrated every year on 5<sup>th</sup> June to raise global awareness to take positive environmental action to protect nature and the planet Earth. It is run by the United Nations Environment Program (UNEP). On the World Environment Day, 5<sup>th</sup> June, 2017, the Environment & Educational Club successfully organized a tree plantation program in a very unique way by using waste plastic bottles called – Reduce, Reuse and Recycle. The plastic materials are Non-Biodegradable. They can not decompose in nature and thus they have detrimental effect on Environment. The aim of this campaign was to raise awareness about the importance of recycling the plastic materials

and the greenery to save our planet. The students collected the waste bottles and decorated the bottles with colors. On this World Environment Day, 18 trees were planted in the waste bottles in order to make hanging garden in the open terrace, in-front of B.C.Roy Auditorium to raise awareness. We were honored to have Dr. Malay R. Dave , Principal of this institution, HODs of different departments and Manager Admin. The program was started with the sharing of views of Principal sir, HODs and other faculties. Next the hanging garden was inaugurated by Principal sir. The program was started with the sharing of views of Principal sir, HODs and other faculties. Next the hanging garden was inaugurated by Principal sir. The voluntary, enthusiastic participation of faculties and staffs of JIS College of Engineering made the event successful. Students were deliberately kept out of this event due to the semester examinations.

Following are some of the pictures of the said event:



Our honorable Principal, Dr. Malay R. Dave, expresses his opinion.





Inauguration of Hanging Garden by respected Principal sir



The Hanging Garden in-front of B.C.Roy Auditorium Hall

On the celebration of Earth Day, 2016 a tree plantation program followed by a Seminar was organized to raise awareness about the importance of greenery to save our planet. In regard to this, trees were planted in the JISCE, Kalyani campus. We were honored to have Professor Debasish Das, HOD of Department of Environmental Science, Kalyani University as our chief guest in the seminar.



**Tree plantation in JISCE campus**

**Seminar on “Everyday is Earth Day”**

On the **World Environment Day, 2015** all the faculty members, staffs were requested to bring a sapling and donate to the Club. These saplings were planted at the college premises, as a part of our endeavour to make JIS College of Engineering a greener, better campus. The voluntary, enthusiastic participation of faculties and staffs of JIS College of Engineering made the event successful.



**Dr. Sabyasachi Sen, HOD, Dept. Of Physics**

Environment and Education club conducted Inter Departmental Eco Quiz Competition and Poster Competition on “Global Warming” in 2014. Since our club deals with environment concerns, the Quiz exclusively focused on environmental issues.





**1<sup>st</sup> position: Koustav Das (EIE-1B)**

**The Quiz Master Mr. Subhrangshu Ray conducti the quiz**

A campaign was to raise awareness about the importance of greenery to save our planet a tree plantation and distribution event called – Plant for the Planet organized by our club in 2014. Trees were planted in the college campus and distributed to the passerby in order to raise awareness. As a promise for a greener world, thumb prints were taken from all the participants, instead of a regular signature campaign. This was done in the form of a tree to keep with the spirit of the event.



**The entire team**





**Trees being planted by the GM, Corporate, Sila Singh Ghosh**