



JIS College of Engineering



R21

Curriculum & Syllabus for B.Tech Under Autonomy

Electronics and Communication Engineering

(Effective From 2021-22 admission Batch)

Electronics & Communication Engineering

Vision of the Institute (IV):

To develop a **sustainable ecosystem** of technical education while fostering **quality in teaching-learning** and research through **techno-pedagogical approach, capacity building**, inculcating **ethical values & leadership qualities** to create the **global citizen** for **serving the society**.

Mission of the Institute (IM):

IM1

World Class Education - Provide a **state-of-the-art educational infrastructure** and enriching **project-based learning** environment conducive to **higher learning** for students, **internships** in leading organizations, participation in **national and international community service** projects.

IM2

Cutting-edge Research - Maintain a **vibrant research environment** creating opportunities for **intellectual engagement** of students in cutting edge **interdisciplinary research** and **innovation** through **collaborative work** with **local, regional and international communities**.

IM3

Capacity Development - Conduct **capacity development programs** for **skilling, up-skilling and re-skilling** of faculties & students by involving practitioners from **governments, corporations, and civil society organizations** to enhance their **management & leadership qualities** as well as commitment to **professional ethics**.

IM4

Impactful People - Promote a culture of **excellence in curricular, co-curricular and extracurricular activities** of the Institute by implementing good practices aimed at **personal and professional development** of students, faculty members & non-academic staffs.

Vision of the Department (DV):

To excel in electronics & communication engineering in order to meet the challenges of **modern industrial society** through **quality technical education, research, innovation and teamwork**.

Mission of the Department (DM):

DM1

To educate students from the foundation to the **state-of-art knowledge** in the **development of electronic devices and communication systems** with **design optimizations**.

DM2

To nourish the mind of growing engineers through **qualitative evaluations, internal assessments, corporate trainings, efficient technical communication skills** and **creative project assignments**.

DM3

To motivate the engineers of the future through competition in **communication skill, seminar presentation, project, and group discussion**.

DM4

To encourage the intended engineers in **kind, humble and moral behavior** with ignition in mind to contribute for the **welfare of society**

State the Program Educational Objectives (PEOs)

PEO1

Graduates will have a strong foundation in engineering, science, and technology that will enable them to succeed as engineers and innovators in their respective fields.

PEO2

Graduates will comprehend, analyze, develop, & design unique products to address real-world challenges.

PEO3

Graduates will pursue their education beyond the undergraduate level, conduct diverse research, and advance their professional competencies.

PEO4

Graduates will recognize, formulate, and use professional skills and ethics to address industrial, societal, and environmental concerns.

PEO5

Graduates will communicate efficiently and maintain ethical guidelines as a member or leader in a group and as an entrepreneur.

PROGRAM OUTCOMES (POs)

Engineering Graduates will be able to:

1. **Engineering knowledge:** Apply the knowledge of mathematics, science, engineering fundamentals, and an engineering specialization to the solution of complex engineering problems.
2. **Problem analysis:** Identify, formulate, review research literature, and analyze complex engineering problems reaching substantiated conclusions using first principles of mathematics, natural sciences, and engineering sciences.
3. **Design/development of solutions:** Design solutions for complex engineering problems and design system components or processes that meet the specified needs with appropriate consideration for the public health and safety, and the cultural, societal, and environmental considerations.
4. **Conduct investigations of complex problems:** Use research-based knowledge and research methods including design of experiments, analysis and interpretation of data, and synthesis of the information to provide valid conclusions.
5. **Modern tool usage:** Create, select, and apply appropriate techniques, resources, and modern engineering and IT tools including prediction and modeling to complex engineering activities with an understanding of the limitations.
6. **The engineer and society:** Apply reasoning informed by the contextual knowledge to assess societal, health, safety, legal and cultural issues and the consequent responsibilities relevant to the professional engineering practice.
7. **Environment and sustainability:** Understand the impact of the professional engineering solutions in societal and environmental contexts, and demonstrate the knowledge of, and need for sustainable development.
8. **Ethics:** Apply ethical principles and commit to professional ethics and responsibilities and norms of engineering practice.
9. **Individual and teamwork:** Function effectively as an individual, and as a member or leader in diverse teams, and in multi-disciplinary settings.
10. **Communication:** Communicate effectively on complex engineering activities with the engineering community and with society at large, such as, being able to comprehend and write effective reports and design documentation, make effective presentations, and give and

receive clear instructions.

11. **Project management and finance:** Demonstrate knowledge and understanding of the engineering and management principles and apply these to one's own work, as a member and leader in a team, to manage projects and in multi-disciplinary environments.

12. **Life-long learning:** Recognize the need for and have the preparation and ability to engage in independent and life-long learning in the broadest context of technological change.

Program Specific Outcomes (PSOs)

1. **PSO1: Technical Knowledge and Analysis:** Ability to Identify, Formulate & Solve problems of Analog & Digital Circuits, Communication, Networking, Signal & Systems, Computer Programming, Embedded Systems and Semiconductor Technology by applying the knowledge of Basic Sciences, Engineering Mathematics and Engineering fundamentals.

2. **PSO2: Design & Implementation:** Ability to design the systems of Electronics & Communication Engineering using advanced hardware and software tools with analytical skills to achieve societal needs keeping environmental awareness intact.

1. **PSO3: Creation of Professional Engineers:** Ability to analyze and transfer knowledge of various areas, like Communication Systems, Signal Processing, SoC (System on a Chip), VLSI and Nanotechnology to achieve a successful career as Engineering Professional, Researcher, Academician and Entrepreneur who can who can direct to implement the real-world applications along with ethical responsibility.

**Curriculum for B.Tech
Electronics & Communication Engineering (Effective From
2021-22 admission Batch)**

L-Lecture; T-Tutorial; P-Practical [1L=1Cr,1T=1Cr,1P=0.5Cr]

First Year First Semester

I.N	Category	Course Code	Course Title	Hours per week				Credits
				L	T	P	Total	
A. THEORY								
1	Basic Science course	CH101	Chemistry-I	3	0	0	3	3
2	Basic Science course	M101	Mathematics-I	4	0	0	4	4
3	Engineering Science Courses	EE101	Basic Electrical Engineering	3	0	0	3	3
4	Humanities and Social Sciences including Management courses	HSMC101	Professional Communication	2	0	0	2	2
B. PRACTICAL								
5	Basic Science courses	CH191	Chemistry-I Lab	0	0	3	3	1.5
6	Engineering Science Courses	EE191	Basic Electrical Engineering Lab	0	0	3	3	1.5
7	Engineering Science Courses	ME 192	Engineering Graphics & Design Lab	0	0	3	3	1.5
8	PROJECT	PR191	Theme based Project I	0	0	1	1	0.5
9	PROJECT	PR192	Skill Development I:Soft Skill	0	0	1	1	0.5
C. MANDATORY ACTIVITIES/COURSES								
10	Mandatory Course	MC181	Induction Program	0	0	0	0	2Units
TOTAL CREDIT								17.5

First Year 2nd Semester

Sl. No.	Category	Course Code	Course Title	Hours per week				Credits
				L	T	P	Total	
A. THEORY								
1	Basic Science courses	PH201	Physics-I	3	0	0	3	3
2	Basic Science courses	M201	Mathematics–II	4	0	0	4	4
3	Engineering Science Courses	CS201	Programming for Problem Solving	3	0	0	3	3
B. PRACTICAL								
4	Basic Science course	PH291	Physics-I Lab	0	0	3	3	1.5
5	Humanities and Social Sciences including Management courses	HSMC291	Professional Communication LAB	0	0	3	3	1
6	Engineering Science Courses	ME291	Workshop & Manufacturing Practices Lab	0	0	3	3	1.5
7	Engineering Science Courses	CS291	Programming for Problem Solving Lab	0	0	3	3	1.5
8	PROJECT	PR291	Theme based Project II	0	0	1	1	0.5
9	PROJECT	PR292	Skill Development II: Life Skill	1	0	0	1	0.5
C. MANDATORY ACTIVITIES/COURSES								
10	Mandatory Course	MC281	NSS/ Physical Activities /Meditation & Yoga /Photography/Nature Club	0	0	3	3	3 Units
TOTAL CREDIT								16.5

**Curriculum for B.Tech
Electronics & Communication Engineering (Effective From
2021-22 admission Batch)**

**L-Lecture; T-Tutorial; P-Practical [1L=1Cr,1T=1Cr,1P=0.5Cr]
2ndYear1stSemester:3rdSemester**

Sl. No.	Category	Course Code	Course Title	Hours per week				Credits/ Unit
				L	T	P	Total	
A.THEORY								
1	BS	M 301	Mathematics III	3	0	0	3	3
2	ES	EC301	Data Structure	3	0	0	3	3
3	ES	EC302	Circuit Theory & Network	3	0	0	3	3
4	PC	EC303	Electronic Devices	3	0	0	3	3
5	PC	EC304	Signal & Systems	3	0	0	3	3
6	HSMC	HSMC303	Universal Human Values 2:UnderstandingHarmony	3	0	0	3	3
B.PRACTICAL								
7	ES	M(CS)391	Numerical Methods Lab	1	0	3	3	2.5
8	ES	EC391	Data Structure Lab	0	0	3	3	1.5
9	ES	EC392	Circuit Theory & Network Lab	0	0	3	3	1.5
10	PC	EC393	Electronic Devices Lab	0	0	3	3	1.5
11	PROJECT	PR391	Theme based Project III	0	0	1	1	0.5
12	PROJECT	PR392	Skill Development III: Technical Seminar Presentation	0	0	1	1	0.5
C.MANDATORYACTIVITIES/COURSES								
13	MC	MC301	Environmental Science	3	0	0	3	0
TOTALCREDITWITHOUTMOOCSCOURSES								26.0
D.MOOCSCOURSES**								
14	MOOCS COURSES	HM301	MOOCS COURSE-II	1	3	1	4	4
TOTALCREDITWITHMOOCSCOURSES								30

****MOOCS COURSES for HONOURS/MINOR Degree are Program specific and to be taken from MOOCS BASKET**

**Curriculum for B.Tech
Electronics & Communication Engineering (Effective From
2021-22 admission Batch)**

L-Lecture; T-Tutorial; P-Practical [1L=1Cr,1T=1Cr,1P=0.5Cr]

2nd Year 2nd Semester: 4th Semester

Sl. No.	Category	Course Code	Course Title	Hours per week				Credits/Unit
				L	T	P	Total	
A. THEORY								
1	PC	EC401	EM Theory & Antenna	3	0	0	3	3
2	PC	EC402	Analog Circuits	3	0	0	3	3
3	PC	EC403	Digital Electronics	3	0	0	3	3
4	PC	EC404	Analog & Digital Communication	3	0	0	3	3
5	PC	EC405	Digital Signal Processing	3	0	0	3	3
6	HSMC	HSMC402	Gender Culture and Development	2	0	0	2	2
B. PRACTICAL								
7	PC	EC491	EM Theory & Antenna Lab	0	0	3	3	1.5
8	PC	EC492	Analog Circuits Lab	0	0	3	3	1.5
9	PC	EC493	Digital Electronics Lab	0	0	3	3	1.5
10	PC	EC494	Analog & Digital Communication Lab	0	0	3	3	1.5
11	PC	EC495	Digital Signal Processing Lab	0	0	3	3	1.5
12	PROJECT	PR491	Theme based Project IV	0	0	1	1	0.5
13	PROJECT	PR492	Skill Development IV: SoftSkill & Aptitude	0	0	1	1	0.5
C. MANDATORY ACTIVITIES/ COURSES								
14	MC	MC481	Learning an Art Form [vocal or instrumental, dance, painting, clay modeling, etc.] OR Environmental Protection Initiatives	0	0	3	3	0
TOTAL CREDIT WITHOUT MOOCS COURSES								25.5
D. MOOCS COURSES								
14	MOOCS COURSES	HM401	MOOCS COURSE-III	3	1	0	4	4
TOTAL CREDIT WITH MOOCS COURSES (FOR CSE, ECE, EE, EIE)								29.5

****MOOCS COURSES for HONOURS/MINOR Degree are Program specific and to be taken from**

MOOCS BASKET

Curriculum for B.Tech Under Autonomy

Electronics & Communication Engineering (Effective From 2021-22 admission Batch)

L-Lecture;T-Tutorial;P-Practical[1L=1Cr,1T=1Cr,1P=0.5Cr]

3rd Year 1st Semester: 5thSemester

Sl. No.	Category	Course Code	Course Title	Hours per week				Credits/ Unit
				L	T	P	Total	
A. THEORY								
1	HSMC	HSMC505	Principles of Management	2	0	0	2	2
2	PC	EC501	Microprocessor & MicroController	3	0	0	3	3
3	PC	EC502	RF & Microwave Engineering	3	0	0	3	3
4	PC	EC503	Computer Network	3	0	0	3	3
5	PE	EC504	Professional Elective-I A:Mobile Communication & Network B:Fiber Optic Communication C: Electronics Measurement & Instrumentation D:Satellite Communication	3	0	0	3	3
6	PE	EC505	Professional Elective-II A:Computer Architecture B:Digital Image & Video Processing C:Embedded System D:Advanced Python Programming	3	0	0	3	3
B. PRACTICAL								
7	PC	EC591	Microprocessor & MicroController Lab	0	0	3	3	1.5
8	PC	EC592	RF & Microwave Engineering Lab	0	0	3	3	1.5
9	PE	EC594	Professional Elective-I Lab A: Mobile Communication & Network Lab B:Fiber Optic Communication Lab C: Electronics Measurement & Instrumentation Lab D:Satellite Communication Lab	0	0	3	3	1.5
10	PE	EC595	Professional Elective-II Lab A:Computer Architecture Lab B:Digital Image & Video Processing Lab C:Embedded System Lab D:Advanced Python Programming Lab	0	0	3	3	1.5
11	PROJECT	PR591	Minor Project I	0	0	3	2	1
12	PROJECT	PR592	Skill Development V:SoftSkill & Aptitude-II	0	0	1	1	0.5
C. MANDATORY ACTIVITIES/COURSES								
13	MC	MC501	Constitution of India	2	0	0	2	0
TOTAL CREDIT WITHOUT MOOCS COURSES								24.5
D.MOOCSCOURSES**[For Honors/Minor]								
14	MOOCS COURSES	HM501	MOOCS COURSE-IV	3	1	0	4	4
TOTAL CREDIT WITH MOOCS COURSES								28.5

****MOOCS COURSES for HONOURS/MINOR Degree are Program specific and to be taken from MOOCS BASKET**

Curriculum for B.Tech Under Autonomy

Electronics & Communication Engineering (Effective From 2021-22 admission Batch)

L-Lecture;T-Tutorial;P-Practical[1L=1Cr,1T=1Cr,1P=0.5Cr]

3rd Year 2nd Semester: 6th Semester

Sl. No.	Category	Course Code	Course Title	Hours per week				Credits /Unit
				L	T	P	Total	
A. THEORY								
1	HSMC	HSMC604	Economics for Engineers	2	0	0	2	2
2	PC	EC601	VLSI & Microelectronics	3	0	0	3	3
3	PC	EC602	Control System	3	0	0	3	3
4	PE	EC603	Professional Elective-III A:Information Theory & Coding B: Renewable Energy Sources & Applications C:NanoTechnology D:Remote Sensing & GIS	3	0	0	3	3
5	OE	EC604	Open Elective-I A: Object Oriented Programming using JAVA. B: Fundamentals of Sensors &Transducers C:Introduction to Quantum Computing D:Fundamentals of Operating System	3	0	0	3	3
6	OE	EC605	Open Elective-II A:Database Management System B:3DPrinting and Design C:Web Intelligence & Big Data D:Scientific Computing	3	0	0	3	3
B. PRACTICAL								
7	PC	EC691	VLSI& Microelectronics Lab	0	0	3	3	1.5
8	PC	EC692	Control System Lab	0	0	3	3	1.5
9	OE	EC694	Open Elective-I Lab A: Object Oriented Programming using JAVA Lab B:Fundamentals of Sensors & Transducers Lab C:Quantum Computing Lab D:Fundamentals of Operating System Lab	0	0	3	3	1.5
10	OE	EC695	Open Elective-II Lab A:Database Management System Lab B:3DPrinting and Design Lab C: Intelligent wave & Big Data Lab D:Scientific Computing Lab	0	0	3	3	1.5
11	PROJECT	PR691	Minor Project II	0	0	3	2	1
12	PROJECT	PR692	Skill Development VI: SoftSkill & Aptitude-III	0	0	1	1	0.5
C. MANDATORY ACTIVITIES/COURSES								
13	MC	MC601	Intellectual Property Right	2	0	0	2	0
TOTAL CREDIT WITHOUT MOOCS COURSES								24.5
D. MOOCS COURSES**								
14	MOOCS COURSES	HM601	MOOCS COURSE-V	3	1	0	4	4
TOTALCREDITWITHMOOCS COURSES								28.5

****MOOCS COURSES for HONOURS/MINOR Degree are Programs specific and to be taken from MOOCS BASKET**

Curriculum for B.Tech Under Autonomy

Electronics & Communication Engineering (Effective From 2021-22 admission Batch)

L-Lecture;T-Tutorial;P-Practical[1L=1Cr,1T=1Cr,1P=0.5Cr]

4th Year 1st Semester: 7th Semester

Sl. No	Course Code	Paper Code	Theory	Contact Hours /Week				Credits/ Unit
				L	T	P	Total	
A.THEORY								
1	PE	EC701	Professional Elective-IV A: Internet of Things B: Artificial Intelligence C:Digital Control System D:Cloud Computing (AWS)	3	0	0	3	3
2	PE	EC702	Professional Elective-V A:Biomedical Electronics & Imaging B:Introduction to EDA tool C: Radar & Missile Communication D:Introduction to MEMS	3	0	0	3	3
3	OE	EC703	Open Elective-III A:DataScience B:Machine Learning C:Cyber Security & Cryptography D:Advanced Bio Signal Processing E:Mixed signal Design	3	0	0	3	3
B.PRACTICAL								
4	PE	EC791	Professional Elective-IV lab A:Internet of Things Lab B: Artificial Intelligence Lab C:Digital Control System Lab D:Cloud Computing (AWS) Lab	0	0	0	3	1.5
5	OE	EC793	Open Elective-III Lab A:Data Science Lab B:MachineLearningLab C: Cyber Security & Cryptography Lab D:Advanced BioSignal Processing Lab E:Mixed signal Design Lab	0	0	3	3	1.5
6	PROJECT	PR791	Major Project-I	0	0	0	4	2
7	PROJECT	PR792	Skill Development VII: Seminar & Group Discussion	0	0	1	1	0.5
8	PROJECT	PR793	Industrial Training/Internship	0	0	0	0	1
C.MANDATORY ACTIVITIES/COURSES								
9	MC	MC701	Entrepreneurship & Innovation Skill	2	0	0	2	0
TOTAL CREDIT WITHOUT MOOCS COURSES								15.5
E. MOOCS COURSES**								
10	MOOCS COURSES	HM701	MOOCS COURSE-VI	3	1	0	4	4
TOTAL CREDIT WITH MOOCS COURSES								19.5

*Collective Data from 3rd to 6th Semester (Summer/Winter Training during Semester Break & Internship should be done after 5th semester or 6th Semester). All related **certificates to be collected by the**

Curriculum for B.Tech Under Autonomy**Electronics & Communication Engineering (Effective From 2021-22 admission Batch)****L-Lecture;T-Tutorial;P-Practical[1L=1Cr,1T=1Cr,1P=0.5Cr]**

training/internship coordinator(s).

****MOOCS COURSES for HONOURS/MINOR Degree are Program specific and to be taken from MOOCS BASKET****4th Year 2nd Semester: 8th Semester**

Sl.No	Course Code	Paper Code	Theory	Contact Hours /Week				Credits /Unit
				L	T	P	Total	
A. THEORY								
1	PE	EC801	Professional Elective-VI A:Industrial Automation & Robotics B:Electronic System Design C:Automotive Electronics D:Adaptive Signal Processing	3	0	0	3	3
2	OE	EC802	Open Elective-IV A:Block Chain B:Deep Learning C: Biology for Engineers D:Foreign Language E:Product Design & Manufacturing Processes F:Business Research Method	3	0	0	3	3
B. PRACTICAL								
3	PROJECT	PR891	Major Project-II	0	0	0	12	6
4	PROJECT	PR892	Grand Viva	0	0	0	0	1
C. MANDATORY ACTIVITIES/COURSES								
5	MC	MC801	Essence of Indian Knowledge Tradition	3	0	0	3	0
TOTAL CREDIT								13

R21(B.TechECE)

Curriculum for B.Tech Under Autonomy
Electronics & Communication Engineering (Effective From
2021-22 admission Batch)

Total FORECE		
Semester	Without MOOCS	WithMOOCS
I	13	13
II	21	21
III	26	30
IV	25.5	29.5
V	24.5	28.5
VI	24.5	28.5
VII	15.5	19.5
VIII	13.0	13
Total:	163	183(forHonors/minor)

R21(B.TechECE)

Curriculum for B.Tech Under Autonomy Electronics & Communication Engineering (Effective From 2021-22 admission Batch)

Credit Distribution

SubjectCategory	Subjects	CreditDis tributiona s perAICT E(%)	Suggeste dBreaku p ofCredits (Total160) asperAI CTE	As perR 21 Curr iculu m
Humanitiesand SocialSciencesincludingM anagementcourses(HSMC)	Humanities & SocialScience: (i)English(ii)Language/EnglishLab Management courses (i)Principle ofManagement,(ii)EconomicsforEngineers(iii) PrinciplesofManagement(iv)Values&Ethicsin Profession	5to10%	8-16	9 5.63 %
Basic Sciences(BS)	Physics (i)Introduction to Electromagnetic Theory (ii)Introduction to Mechanics (iii)Quantum Mechanics for Engineers (iv) Oscillation, Waves andOptics (v) SemiconductorOptoelectronics(vi) SemiconductorPhysics	15 to 20%		

R21(B.TechECE)

Curriculum for B.Tech Under Autonomy Electronics & Communication Engineering (Effective From 2021-22 admission Batch)

	<p>Chemistry & Biology(i)Chemistry – I (Concepts inchemistry for engineering)(ii)Chemistry LaboratoryElective Courses</p> <p>(i)Chemistry-II (ChemicalApplications) (ii)Polymer Chemistry(iii)Experiments in PolymerChemistry</p> <p>Biology</p>			
	<p>Mathematics</p> <p>(i)Mathematics(Option1)</p> <p>Mathematics1</p> <p>Mathematics2</p> <p>Mathematics3</p>			

R21(B.TechECE)

Curriculum for B.Tech Under Autonomy Electronics & Communication Engineering (Effective From 2021-22 admission Batch)

	(ii) Mathematics (Option 2) (for CSE students)			
Engineering Sciences and Skills (ES)	(i) Workshop/Manufacturing Practice (ii) Drawing / Engineering Graphics & Design, (iii) Basics of Electrical (iv) Computer / Programming for Problem Solving (v) Numerical Methods (vi) Circuit theory	15 to 20 %	24-32	23.5 14.6 9%
Professional core courses (PC)	Courses relevant to chosen branch	30 to 40 %	48-64	51 31.8 8%
Professional Elective	Elective courses relevant to chosen specialization/branch	10 to 15 %	16-24	22.5 14.0 6%
Open Elective	Elective Courses from other technical programs and/or emerging subjects: 1. Artificial Intelligence (AI) 2. Internet of Things (IoT) 3. BlockChain 4. Robotics 5. Quantum Computing 6. Data Sciences 7. CyberSecurity 8. 3D Printing and Design 9. Virtual Reality (VR)	5 to 10 %	8-16	16.5 10.3 1%

Curriculum for B.Tech Under Autonomy Electronics & Communication Engineering (Effective From 2021-22 admission Batch)

Projectwork,seminarandinternshipinindustryorelsewhere	(i) PROJECT(PR...91):Project work (ii)PROJECT(PR...92): (iii) PROJECT(PR...93): (iv) IndustrialTraining/Internship (iv)GrandViva-1	10to15 %	16-24	17.5 10.9 4 %
MandatoryCourses[Environmental Sciences,Inductiontraining,IndianConstitution, Essenceof	<p style="text-align: center;">MCCourses:</p> <p style="text-align: center;">(i)Environmental Science,(ii)Foreignlanguage,(iii)ConstitutionofIndia(iv)Behavioral&Interpersonalskills (v)Essence of IndianKnowledgeTradition</p> <p style="text-align: center;">&othersasmentionedin AICTEguidelines</p>	NoCred itCourse	Minimum2units persemester Max: 28Units/Program	e11of Pag

Indian Knowledge Tradition]	<p style="text-align: center;">MC</p> <p>Activities:(i) Induction Programmin g(ii)NSS/NCC/Yoga(iii) Technical Lecture Presentation</p> <p style="text-align: center;">& others as mentioned in AICTE guidelines</p>			
-----------------------------	--	--	--	--

Summary:

Sub	Credit	%	AICTE %
HSMC	9	5.63	5to10
BSHU	20	12.5	15to20
ES	23.5	14.69	15to20
PC	51	31.88	30to40
PE	22.5	14.06	10to15
OE	16.5	10.31	5to10
Project	17.5	10.94	10to15
	160	100.00	

Professional Electives (It is expected Options in a vertical column would lead to expertise in a specific/allied domain)				
	Option 1	Option 2	Option 3	Option 4
Professional Elective I (With Lab)	A: Mobile Communication & Network	B: Fibre Optic Communication	C: Electronics Measurement & Instrumentation	D: Satellite Communication
Professional Elective II (With Lab)	A: Advanced Microprocessor & Microcontroller	B: Digital Image & Video Processing	C: Embedded System	D: Python Programming
Professional Elective III (Without Lab)	A: Information Theory & Coding	B: Renewable Energy Sources & Applications	C: Nano Technology	D: Remote Sensing & GIS
Professional Elective IV (With Lab)	A: Internet of Things	B: Artificial Intelligence	C: Digital Control System	D: Cloud Computing (AWS)
Professional Elective V (Without Lab)	A: Biomedical Electronics & Imaging	B: Physical Design, Verification & Testing	C: Radar & Missile Communication	D: Introduction to MEMS
Professional Elective VI (Without Lab)	A: Industrial Automation & Robotics	B: Electronic System Design	C: Automotive Electronics	D: Adaptive Signal Processing

Open Electives (It is expected Options in a vertical column would lead to expertise in a specific/allied domain)				
	Option 1	Option 2	Option 3	Option 4
Open Elective I (With Lab)	A: Object Oriented Programming using JAVA.	B: Fundamentals of Sensors & Transducers	C: Quantum Computing	D: Fundamental of Operating System
Open Elective II (With Lab)	A: Database Management System	B: 3D Printing and Design	C: Intelligent wave & Big Data	D: Scientific Computing
Open Elective III (With Lab)	A: Data Science	B: Machine Learning	C: Cyber Security & Cryptography	D: Advanced Bio Signal Processing E: Computer Architecture
Open Elective IV (Without Lab)	A: Block Chain	B: Probability & Stochastic Process	C: Biology for Engineers	D: Foreign Language E: Project Design

					& ManufacturingPr ocesses F: BusinessResearc hMethod
--	--	--	--	--	---

MOOCs (It is expected Options in a vertical column would lead to expertise in a specific/allied domain)						
	Sem	Credit	Option1	Option2	Option3	Option4
MOOCS COURSE-I	II	2	CoursereLATEDtoMAR			
MOOCSCOU RSE-II	III	4	Related toMinor/Honors	Related toMinor/Honors	Related toMinor/Honors	RelatedtoMinor /H onors
MOOCSCOU RSE-III	IV	4	Related toMinor/Honors	Related toMinor/Honors	Related toMinor/Honors	RelatedtoMinor /Honors
MOOCSCOU RSE-IV	V	4	Related toMinor/Honors	Related toMinor/Honors	Related toMinor/Honors	RelatedtoMinor /H onors
MOOCSCOU RSE-V	VI	4	Related toMinor/Honors	Related toMinor/Honors	Related toMinor/Honors	RelatedtoMinor /H onors
MOOCSCOU RSE-VI	VII	4	Related toMinor/Honors	Related toMinor/Honors	Related toMinor/Honors	RelatedtoMinor /H onors

**Please define your Honors/Minor programme credit point of 20 to be earned by the student. Related BoS would endorse the selection of these courses followed by the necessary intimation at the Academic Council of the Institute.

***In2ndsemesterMOOCs course credit would be contributed to MARSCORE

Curriculum for B.Tech Under Autonomy

Electronics&CommunicationEngineering

(Effectivefrom2021-22admissionBatch)

L–Lecture; T-Tutorial;P-Practical[1L=1Cr,1T=1Cr, 1P=0.5Cr]

First Year First Semester

Sl.N	Category	CourseCode	CourseTitle	Hoursperweek				Credits
				L	T	P	Total	
A.THEORY								
1	BasicSciencecourse	CH101	Chemistry-I	3	0	0	3	3
2	BasicSciencecourse	M101	Mathematics–I	4	0	0	4	4
3	Engineering ScienceCourses	EE101	Basic ElectricalEngineering	3	0	0	3	3
4	Humanities andSocial SciencesincludingManagementcourses	HSMC101	ProfessionalCommunication	2	0	0	2	2
B.PRACTICAL								
5	BasicSciencecourse	CH191	Chemistry-ILab	0	0	3	3	1.5
6	Engineering ScienceCourses	EE191	Basic ElectricalEngineeringLab	0	0	3	3	1.5
7	Engineering ScienceCourses	ME 192	Engineering Graphics &DesignLab	0	0	3	3	1.5
8	PROJECT	PR191	Themebased ProjectI	0	0	1	1	0.5
9	PROJECT	PR192	Skill Development I:Soft Skill	0	0	1	1	0.5

	C.MANDATORYACTIVITIES/COURSES							
10	MandatoryCourse	MC181	InductionProgram	0	0	0	0	2Units
	TOTALCREDIT							17.5

First Year 2nd Semester

Sl. No.	Category	CourseCode	CourseTitle	Hoursperweek				Credits
				L	T	P	Total	
A.THEORY								
1	BasicSciencecourses	PH201	Physics-I	3	0	0	3	3
2	BasicSciencecourses	M 201	Mathematics–II	4	0	0	4	4
3	EngineeringScienceCourses	CS 201	Programming for ProblemSolving	3	0	0	3	3
B.PRACTICAL								
4	BasicSciencecourse	PH291	Physics-ILab	0	0	3	3	1.5
5	Humanities and SocialSciences includingManagementcourses	HSMC291	ProfessionalCommunicationLAB	0	0	3	3	1
6	Engineering ScienceCourses	ME 291	Workshop & ManufacturingPracticesLab	0	0	3	3	1.5
7	Engineering ScienceCourses	CS 291	Programming for ProblemSolving Lab	0	0	3	3	1.5
8	PROJECT	PR291	ThemebasedProjectII	0	0	1	1	0.5
9	PROJECT	PR292	Skill Development II:LifeSkill	1	0	0	1	0.5
C.MANDATORYACTIVITIES/COURSES								
10	MandatoryCourse	MC281	NSS/ Physical Activities /Meditation & Yoga /Photography/NatureClub	0	0	3	3	3 Units
TOTALCREDIT								16.5

COURSE NAME: CHEMISTRY

COURSE CODE: CH 101

CONTACT: 3:0:0

TOTAL CONTACT HOURS: 36

CREDITS: 3

Course Outcomes (COs):

After completion of this course students will be able to

CO1: Describe the fundamental properties of atoms & molecules, atomic structure and the periodicity of elements in the periodic table

CO2: Apply fundamental concepts of thermodynamics in different engineering applications.

CO3: Apply the knowledge of water quality parameters, corrosion control & polymers to different industries.

CO4: Determine the structure of organic molecules using different spectroscopic techniques.

CO5: Evaluate theoretical and practical aspects relating to the transfer of the production of chemical products from laboratories to the industrial scale, in accordance with environmental considerations.

CO-PO MAPPING

CO	PO1	PO2	PO3	PO4	PO5	PO6	PO7	PO8	PO9	PO10	PO11	PO12
CO1	1	2	2	2	2					1	2	2
CO2	2	2	2	2	1		2	1		1		2
CO3	2	2	2	2	2	1	1	1		1		2
CO4	2	2	2	2	2					1	1	2
CO5	2	2	2	2	1	1	1	1	1		2	2
AVG	2.4	3.0	2.8	2.6	2.0	1.0	1.3	1.0	1.0	1.0	1.7	2.4

COURSE NAME: MATHEMATICS-I

COURSE CODE: M 101

CONTACT: 4:0:0

TOTAL CONTACT HOURS: 48

CREDITS: 4

Course Outcomes (COs):

On successful completion of the learning sessions of the course, the learner will be able to

CO1: Recall the properties and formula related to matrix algebra, differential calculus, multivariable calculus, vector calculus and infinite series.

CO2: Determine the solutions of the problems related to matrix algebra, differential calculus, multivariable calculus, vector calculus and infinite series.

CO3: Apply the appropriate mathematical tools of matrix algebra, differential calculus, multivariable calculus, vector calculus and infinite series for the solutions of the problems.

CO4: Analyze different engineering problems linked with matrix algebra, differential calculus, multivariable calculus, vector calculus.

CO-PO MAPPING:

CO	PO											
	PO1	PO2	PO3	PO 4	PO5	PO6	PO7	PO8	PO9	PO10	PO11	PO12
CO 1	3	2	1	-	-	-	-	-	-	-	-	1
CO 2	3	3	2	-	-	-	-	-	-	-	-	-
CO 3	3	2	3	1	2	-	-	1	-	-	-	2
CO 4	3	3	2	3	-	-	-	1	-	1	1	
AVG	3	2.5	2	2	2			1		1	1	1.5

COURSE NAME: BASIC ELECTRICAL ENGINEERING

COURSE CODE: EE101

CONTACT: 3:0:0

TOTAL CONTACT HOURS: 36

CREDITS: 3

Course Outcomes (COs):

After attending the course students would be able to

CO1: understand and analyze basic electric circuits

CO2: study the working principles of electrical machines.

CO3: introduce the components of low voltage electrical installations

CO4: study the fundamentals of electrical Power systems and Control Systems

CO-PO MAPPING

CO	PO1	PO2	PO3	PO 4	PO5	PO6	PO7	PO8	PO9	PO10	PO11	PO12
CO1	3	1	-	-	2	2	-	-	-	2	2	1
CO2	2	3	-	-	-	-	-	1	-	1	1	1
CO3	2	3	1	-	1	-	-	-	-	1	1	1
CO4	1	2	3	1	2	-	-	-	-	1	-	1
AVG	2	2.25	2	1	1.67	2		1		1.25	1.3	1

COURSE NAME: PROFESSIONAL COMMUNICATION

COURSE CODE: HSMC 101

CONTACT: 2:0:0

TOTAL CONTACT HOURS: 24

CREDITS: 2

Course Outcomes (COs):

After attending the course students should be able to

CO1: apply the modalities and nuances of communication in a workplace context.

CO2: analyze communication across cultures and societies.

CO3: apply the basic formats, templates of business and official communication.

CO4: employ formal communication modes in meetings and reports.

CO5: justify importance of culturally neutral language in interpersonal and business communication.

CO-PO MAPPING

CO	PO1	PO2	PO3	PO4	PO5	PO6	PO7	PO8	PO9	PO10	PO11	PO12
CO1					1	2	-	2	3	3	2	3
CO2					1	2	-	-	3	3	2	3
CO3					2	2	2	2	3	3	2	3
CO4					1	2	-	-	3	3	2	3
CO5						2	2	2	3	3	2	3
AVG					1.25	2	2	2	3	3	2	3

COURSE NAME: CHEMISTRY LAB

COURSE CODE: CH 191

CONTACT: 0:0:3

CREDITS: 1.5

Course Outcomes (COs):

After attending this course, students would be

CO1:able to operate different types of instruments for estimation of small quantities chemicals used in industries and scientific and technical fields.

CO2:able to analyze and determine the composition of liquid and solid samples working as an individual and also as a team member.

CO3:able to analyze different parameters of water considering environmental issues.

CO4:able to synthesize drug and polymer materials.

CO5: Capable to design innovative experiments applying the fundamentals of chemistry.

CO-PO MAPPING

COs	PO1	PO2	PO3	PO4	PO5	PO6	PO7	PO8	PO9	PO10	PO11	PO12
CO1	1	3	2	2	2	-	-	-	-	1	2	2
CO2	3	3	3	2	1	-	2	1	-	1	-	3
CO3	3	3	3	3	3	1	1	1	-	1	-	2
CO4	2	3	3	3	3	-	-	-	-	1	1	2
CO5	3	3	3	3	1	1	1	-	1	-	2	3
AVG	2.4	3	2.8	2.6	2	1	1.3	1	1	1	1.67	2.4

COURSE NAME: BASIC ELECTRICAL ENGINEERING LABORATORY

COURSE CODE: EE191

CONTACT: 0:0:3

CREDITS: 1.5

Course Outcomes (COs):

After completion of this course students will be able to

- CO1.** Identify and use common electrical components.
- CO2.** Develop electrical networks by physical connection of various components and analyze the circuit behavior.
- CO3.** Apply and analyze the operational characteristics of electrical machines.
- CO4.** Apply and analyze the equivalent parameters, Losses, efficiency of transformers

CO-PO MAPPING

CO	PO1	PO2	PO3	PO4	PO5	PO6	PO7	PO8	PO9	PO10	PO11	PO1 2
CO1	3	-	-	-	-	2	-	-	-	-	-	1
CO2	3	3	-	2	1	-	-	-	1	-	1	1
CO3	3	-	-	1	3	-	-	2	3	1	1	1
CO4	3	3	3	3	3	-	-	2	3	1	-	-
AVG	3	3	3	2	2.33	2		2	2.33	1	1	1

COURSE NAME: ENGINEERING GRAPHICS & DESIGN

COURSE CODE: ME192

CONTACT: 0:0:3

CREDITS: 1.5

Course Outcomes (COs):

After attending the course students would

CO1: get introduced with Engineering Graphics and visual aspects of design.

CO2: know and use common drafting tools with the knowledge of drafting standards.

CO3: be able to apply computer aided drafting techniques to represent line, surface or solid models in different Engineering viewpoints.

CO4: be able to produce part models; carry out assembly operation and show working procedure of a designed project work using animation.

CO-PO MAPPING:

CO	PO1	PO2	PO3	PO4	PO5	PO6	PO7	PO8	PO9	PO10	PO11	PO12
CO1	1	-	1	-	1	1	-	1	2	1	-	-
CO2	2	1	2	-	1	1	-	2	1	2	1	1
CO3	2	1	3	2	3	-	-	2	2	2	1	1
CO4	2	1	3	3	3	1	1	2	2	2	2	2
AVG	1.8	1	2.3	2.5	2	1	1	1.8	1.8	1.8	1.3	1.3

PAPER NAME: PHYSICS –I

PAPER CODE: PH 201

CONTACT: 3:0:0

TOTAL CONTACT HOURS: 36

CREDIT:3

Course Outcomes (COs):

After attending the course students should be able to

CO1: describe various types of mechanical resonance and its electrical equivalence

CO2: explain basic principles of Laser, Optical fibers and Polarization of light

CO3: apply superposition principle to explain interference and diffraction

CO4: analyze different crystallographic structures according to their coordination number and packing factors

CO5: justify the need of quantum mechanics as a remedy to overcome limitations imposed by classical physics

CO-PO Mapping:

Weightage Values: 3=Strongly matched, 2=Moderately matched, 1=Weakly matched, (-)=Not matched

CO	PO1	PO2	PO3	PO4	PO5	PO6	PO7	PO8	PO9	PO10	PO11	PO12
CO1	3	2	-	-	-	-	-	-	-	-	-	2
CO2	3	-	2	1	-	-	1	-	1	-	1	2
CO3	3	2	-	1	2	-	-	1	-	-	-	1
CO4	2	3	-	3	1	-	-	1	1	-	-	1
CO5	1	3	2	1	-	1	-	1	1	1	-	1
AVG	2.4	2.5	2	1.67	1.5	1	1	1	1	1	1	1.4

COURSE NAME: MATHEMATICS-II

COURSE CODE: M 201

CONTACT: 4:0:0

TOTAL CONTACT HOURS: 48

CREDIT: 4

Course Outcomes (COs):

On successful completion of the learning sessions of the course, the learner will be able to

CO1: Recall the properties and formula related to ordinary differential equations, improper integral, Laplace transform and numerical techniques.

CO2: Determine the solutions of the problems related to ordinary differential equations, improper integral, Laplace transform and numerical techniques.

CO3: Apply appropriate mathematical tools of ordinary differential equations, improper integral, Laplace transform and numerical techniques for the solutions of the problems.

CO4: Analyze engineering problems by using differential equation, Laplace Transform and Numerical Methods.

CO-PO Mapping:

Weightage Values: 3=Strongly matched, 2=Moderately matched, 1=Weakly matched, (-)=Not matched

CO	PO1	PO2	PO3	PO4	PO5	PO6	PO7	PO8	PO9	P10	P11	P12
CO1	3	2	2	-	-	-	-	-	1	-	-	1
CO2	3	2	2	-	-	1	-	-	1	-	-	1
CO3	3	2	-	1	2	-	-	2	1	-	1	1
CO4	3	3	2	3	2	-	-	2	1	1	-	1
AVG	3	2.25	2	2	2	1		2	1	1	1	1

COURSE NAME: PROGRAMMING FOR PROBLEM SOLVING

COURSE CODE:CS 201

CONTACT: 3:0:0

TOTAL CONTACT HOURS: 36CREDITS:3

Course Outcomes(COs): After completion the course students will be able to

CO1: Understand the fundamental concept of Computer and mathematical knowledge and apply them in designing solution to engineering problem.

CO2: Understand the basic concept of C programming and use of data types/operators/input/output function for developing and implementing complete program leading to solution of mathematical and engineering problem.

CO3: Use conditional branching, iteration, recursion and formulate algorithms and programs in solving mathematical/scientific/engineering problem leading to lifelong learning.

CO4: Understand the concept of arrays, pointers, file and dynamic memory allocation and apply it for problem solving and also create new data types using structure, union and enum.

CO5: Understand how to decompose a problem into functions and assemble into a complete program by means of modular programming possibly as a team.

CO-PO Mapping:

Weightage Values:3=Strongly matched,2=Moderately matched,1=Weakly matched, (-)=Not matched

COs	PO1	PO2	PO3	PO4	PO5	PO6	PO7	PO8	PO9	PO10	PO11	PO12
CO1	3	2	1	1	-	-	1	-	3	3	1	1
CO2	2	2	3	1	2	2	-	-	3	3	3	3
CO3	2	2	2	3	2	1	-	-	3	3	1	3
CO4	3	2	2	3	2	3	-	-	3	3	2	3
CO5	3	3	3	3	2	3	-	-	3	3	3	3
AVG	2.6	2.2	2.2	2.2	2	2.25	1		3	3	2	2.6

PAPER NAME: PHYSICS I LAB

PAPER CODE: PH 291

CONTACT HOURS: 0:0:3

CREDIT:1.5

Course Outcomes (COs):

After attending the course students will be able to

CO1: demonstrate experiments allied their theoretical concepts

CO2: conduct experiments using LASER, Optical fiber, Torsional pendulum, Spectrometer

CO3: participate as an individual, and as a member or leader in groups in laboratory sessions actively

CO4: analyze experimental data from graphical representations, and to communicate effectively the same in Laboratory reports including innovative experiments

CO-PO MAPPING:

Weightage Values: 3=Strongly matched, 2=Moderately matched, 1=Weakly matched, (-)=Not matched

	PO1	PO2	PO3	PO4	PO5	PO6	PO7	PO8	PO9	PO10	PO11	PO12
CO1	1	-	-	-	2	2	-	1	2	1	2	3
CO2	3	3	3	-	-	-	-	-	2	-	-	2
CO3	2	2	2	2	2	-	-	-	2	-	-	3
CO4	1	2	2	2	2	-	-	-	2	-	-	2
	1.8	2.3	2.3	2	2	2		1	2	1	2	2.5

**COURSE NAME: WORKSHOP/MANUFACTURING
PRACTICES COURSE CODE: ME291**

CONTACT: 0:0:3

CREDITS: 1.5

Course Outcomes (COs):

After completion of this course students will be able to

CO1: Identify and operate various hand tools related to variety of manufacturing operations

CO2: Safely fabricates simple components with their own hands.

CO3: Get practical knowledge of the dimensional accuracies and tolerances applicable for different manufacturing processes.

CO4: Produces small devices of their interest in project or research purpose.

1.

CO-PO Mapping:

Weightage Values: 3=Strongly matched, 2=Moderately matched, 1=Weakly matched, (-)=Not matched

CO	PO1	PO2	PO3	PO4	PO5	PO6	PO7	PO8	PO9	PO10	PO11	PO12
CO1	3	1	2	1	1	-	-	-	2	1	-	2
CO2	3	3	2	2	1	-	-	-	2	1	-	2
CO3	3	2	2	2	1	1	-	1	2	2	3	2
CO4	1	2	1	2	1	1	-	1	2	2	3	2
AVG	2.5	2	1.75	1.75	1	1		1	2	1.5	3	2

COURSE NAME: PROFESSIONAL COMMUNICATION LAB

COURSE CODE: HSMC291

Contact: 0:0:2

CREDIT:1

Course Outcomes (COs):

After attending the course students' would be able to

CO1: explain advanced skills of Technical Communication in English through Language Laboratory.

CO2: apply listening, speaking, reading and writing skills in societal and professional life.

CO3: demonstrate the skills necessary to be a competent Interpersonal communicator.

CO4: analyze communication behaviours.

CO5: adapt to multifarious socio-economical and professional arenas with the help of effective communication and interpersonal skills.

CO-PO MAPPING

Weightage Values: 3=Strongly matched, 2=Moderately matched, 1=Weakly matched, (-)=Not matched

	PO1	PO2	PO3	PO4	PO5	PO6	PO7	PO8	PO9	PO10	PO11	PO12
					2	2	-	1	-	1	2	3
					2	-	-	-	-	-	-	2
					3	-	-	-	-	-	-	3
					3	-	-	-	-	-	-	2
					2	2	3	1	3	3	3	3
					2.4	2	3	1	3	2	2.5	2.6

COURSE NAME: PROGRAMMING FOR PROBLEM SOLVING LAB

COURSE CODE: CS 291

CONTACT: 0:0:3

CREDITS: 1.5

Course Outcomes (COs):

After completion of the course students will be able to

CO1: Understand and propose appropriate command or function in running system or developing program for engineering and mathematical problems depending on the platform used even in changed environment leading to their life long learning.

CO2: Identify and propose appropriate data type, arithmetic operators, input/output functions and also conditional statements in designing effective programs to solve complex engineering problem using modern tools.

CO3: Design and develop effective programs for engineering and mathematical problems using iterative statements as well as recursive functions using modular programming approach possibly as a team maintain in proper ethics of collaboration.

CO4: Explain and organize data in arrays, strings and structures and manipulate them through programs and also define pointers of different types and use them in defining self-referential structures and also to construct and use files for reading and writing to and from leading to solution of engineering and mathematical problem.

CO5: Prepare laboratory reports on interpretation of experimental results and analyze it for validating the same maintaining proper ethics of collaboration.

CO-PO MAPPING:

Weightage Values: 3=Strongly matched, 2=Moderately matched, 1=Weakly matched, (-)=Not matched

	PO1	PO2	PO3	PO4	PO5	PO6	PO7	PO8	PO9	PO10	PO11	PO12
	1	-	-	-	2	2	-	1	2	1	2	3
	3	3	3	-	-	-	-	-	2	-	-	2
	2	2	2	2	2	-	-	-	2	-	-	3
	1	2	2	2	2	-	-	-	2	-	-	2
	2	3	3	3	2	2	3	1	3	3	3	3
	1.8	2.5	2.5	2.3	2	2	3	1	2.2	2	2.5	2.6

Department of Electronics & Communication Engineering

of Electronics & Communication Engineering

R21 (B.Tech ECE)

Curriculum for B.Tech

Under Autonomy

Electronics & Communication Engineering

(Effective From 2021-22 admission Batch)

L–Lecture;T-Tutorial;P-Practical[1L=1Cr,1T=1Cr,1P=0.5Cr]

2ndYear 1stSemester: 3rd Semester

Sl. No.	Category	CourseCode	CourseTitle	Hoursper week				Credits/Unit
				L	T	P	Total	
A.THEORY								
1	BS	M 301	MathematicsIII	3	0	0	3	3
2	ES	EC301	Data Structure	3	0	0	3	3
3	ES	EC302	Circuit Theory &Network	3	0	0	3	3
4	PC	EC303	Electronic Devices	3	0	0	3	3
5	PC	EC304	Signal & Systems	3	0	0	3	3
6	HSMC	HSMC303	Universal Human Values 2:UnderstandingHarmony	3	0	0	3	3
B.PRACTICAL								
7	ES	M(CS)391	Numerical Methods Lab	1	0	3	3	2.5
8	ES	EC391	Data Structure Lab	0	0	3	3	1.5
9	ES	EC392	Circuit Theory & Network Lab	0	0	3	3	1.5
10	PC	EC393	Electronic Devices Lab	0	0	3	3	1.5
11	PROJECT	PR391	Theme based Project III	0	0	1	1	0.5

Department of Electronics & Communication Engineering

of Electronics & Communication Engineering

12	PROJECT	PR392	Skill Development III: Technical Seminar Presentation	0	0	1	1	0.5
C.MANDATORY ACTIVITIES / COURSES								
15	MC	MC301	Environmental Science	3	0	0	3	0
TOTAL CREDIT WITHOUT MOOCS COURSES								26.0
D. MOOCS COURSES**								
16	MOOCS COURSES	HM301	MOOCS COURSE-II	1	3	1	4	4
TOTAL CREDIT WITH MOOCS COURSES								30

****MOOCS COURSES for HONOURS/MINOR Degree are Program specific and to be taken from MOOCS BASKET**

CourseName: Mathematics-III

CourseCode:M301

Contact:3:0:0

Total Contact Hours: 36

Credits:3

Prerequisite:

The students to whom this course will be offered must have the concept of (10+2) standard calculus, basic probability and differential equations.

CourseOutcomes:

On successful completion of the learning sessions of the course, the learner will be able to:

CO1: Recall the underlying principle and properties of Fourier series, Fourier transform, probability distribution of a random variable, calculus of complex variable, and partial differential equation.

CO2: Exemplify the variables, functions, probability distribution and differential equations and find their distinctive measures using the underlying concept of Fourier series, Fourier transform, probability distribution of a random variable, calculus of complex variable, and partial differential equation.

CO3: Apply Cauchy's integral theorem and the residue theorem to find the value of complex integration, and compute the probability of real world uncertain phenomena by identifying probability distribution that fits the phenomena.

CO4: Solve partial differential equation using method of separation of variables

CO5: Find the Fourier series and Fourier transform of functions by organizing understandings of underlying principles and also evaluate the integral using Parseval's identity.

Course Content:**MODULE I: *Fourier series and Fourier Transform:* (9 L)**

Fourier series: Dirichlet's Conditions; Euler's Formula for Fourier Series; Fourier Series for functions of period 2π ; Sum of Fourier series (examples); Theorem for the convergence of Fourier series (statement only); Fourier series of a function with its periodic extension; Half range Fourier series: Construction of half range Sine series and half range Cosine Series; Parseval's identity (statement only) and related problems.

Fourier Transform: Fourier Transform, Fourier Cosine Transforms, Fourier Sine Transforms (problems only); Properties of Fourier Transform: Linearity, Shifting, Change of Scale, Modulation (problems only); Fourier Transform of Derivatives (problems only); Convolution Theorem (statement only), Inverse of Fourier Transform (problems only).

MODULE II: *Probability Distributions:* (9 L)

Random Variable: Discrete and Continuous (definition & examples); Probability Distribution (definition & examples); Probability Mass Function, Probability Density Function and Distribution Function for a single random variable only (definition, properties & related problems); Expectation, Variance and Standard Deviation for a single random variable only (definition, properties & related problems); Binomial Distribution, Poisson Distribution, Binomial Approximation to Poisson Distribution and Normal Distribution (problems only), Mean, Variance and Standard Deviation of Binomial, Poisson and Normal Distribution (problems only).

MODULE III: *Calculus of Complex Variable:* (13 L)

Functions of a Complex Variable (definition and examples); Concept of Limit, Continuity and Differentiability (problems only); Analytic Functions (definition and examples); Cauchy-Riemann Equations (statement only & related problems); Sufficient condition for a function to be analytic (statement only & related problems).

Concept of Simple Curve, Closed Curve, Smooth Curve & Contour; Some elementary properties of complex integrals (problems only); Cauchy's Theorem (statement only & related problems); Cauchy's Integral Formula (statement only & related problems); Cauchy's Integral Formula for the derivative of an analytic function (statement only & related problems); Cauchy's Integral Formula for the successive derivatives of an analytic function (statement only & related problems); Taylor's series and Laurent's series (problems only).

Zero of an Analytic Function and its order (definition & related problems); Singularities of an Analytic Function: Isolated Singularity and Non-isolated Singularity (definition & related problems); Essential Singularities, Poles (Simple Pole and Pole of Order m) and Removable Singularities (definition & related problems); Determination of singularities and their nature (problems only); Residue (definition & examples); Determination of the residue of a given function; Cauchy's Residue theorem (statement only & related problems). Application of Residue.

MODULE IV: Partial Differential Equation (PDE):

(5 L)

Solution of PDE: Method of Separation of Variables.

Solution of Initial Value & Boundary Value Problem: One Dimensional Wave Equation, One Dimensional Heat Equation, Two Dimensional Laplace Equation.

Project Domains:

1. Study of physical processes through PDE and ODE.
2. Application of calculus of complex variable in real world engineering problems.
3. Study of uncertainty in real world phenomena using probability distribution.
4. Application of Fourier series and Fourier transform in engineering problems.

Text Books:

1. Herman, R. L. *An Introduction to Fourier Analysis*, Chapman and Hall/CRC, 2016.
2. Grafakos, L. *Classical Fourier Analysis*, Springer, India, Private Ltd.
3. Das, N.G. *Probability and Statistics*; The McGraw Hill Companies.
4. Gupta, S. C. and Kapoor, V. K. *Fundamentals of Mathematical Statistics*, Sultan Chand & Sons.
5. Mathews, J. H. and Howell, R. W. *Complex Analysis for Mathematics & Engineering*, Jones & Bartlett Pub, 2006.
6. Chowdhury, B. *Elements of Complex Analysis*, New Age International, 1993.
7. Raisinghania, M .D. *Advanced Ordinary & Partial Differential. Equation*; S. Chand Publication.
8. Grewal, B. S. *Higher Engineering Mathematics*, Khanna Pub.
9. Kreyszig, E. *Advanced Engineering Mathematics*, John Wiley & Sons, 2006.

Reference Books:

1. Gray, R. M. and Goodman, J. *Fourier Transforms: An Introduction for Engineers*, Springer, US, 1995.
2. Lipschutz & Lipson, *Schaum's Outline in Probability (2ndEd)*, McGraw Hill Education.
3. Spiegel, M. R. *Theory and Problems of Probability and Statistics (Schaum's Outline Series)*, McGraw Hill Book Co.
4. Goon, A.M., Gupta M .K. and Dasgupta, B. *Fundamental of Statistics*, The World Press Pvt. Ltd.
5. Soong, T. T. *Fundamentals of Probability and Statistics for Engineers*, John Wiley & Sons Inc, 2004.
6. Delampady, M. *Probability & Statistics*, Universities Press.

7. Spiegel, M. R. *Theory and Problems of Complex Variables (Schaum's Outline Series)*, McGraw Hill Book Co.
8. Sneddon, I. N. *Elements of Partial Differential Equations*, McGraw Hill Book Co.

CO-PO-PSO MAPPING

CO	PO1	PO2	PO3	PO4	PO5	PO6	PO7	PO8	PO9	P10	P11	P12	PSO1	PSO2	PSO3
CO1	3	1	1	-	-	-	-	-	-	-	-	1	3	2	1
CO2	3	2	1	2	-	-	-	-	-	-	-	1	2	2	2
CO3	3	2	2	-	-	-	-	-	-	-	-	1	2	3	1
CO4	3	2	2	-	-	-	-	-	-	-	-	1	3	2	1
CO5	3	3	2	3	-	-	-	-	-	-	-	1	1	2	1
AVG	3	2	1.6	2.5								1	2.2	2.2	1.2

Course Name: Data Structure

Course Code:EC301

Contact:3:0:0

Total Contact Hours: 36

Credits:3

Prerequisite:Fundamentals of Computer & C Programming

Course Outcome:

CO1: Able to understand the concept of linear and non-linear data structures.

CO2: Able to evaluate the efficiency of algorithms.

CO3: Able to understand searching and sorting techniques

CO4: Able to illustrate the hashing technique.

Course Content:

Module I: Introduction

[2L]

Data and data structure (Linear & Non-linear), abstract Data Type. Algorithms and programs, basic idea of pseudo-code, Algorithm efficiency and analysis, time and space analysis of algorithms, Big-O notations.

Module-II: Arrays & Linked List

[6L]

Different representations - row major, column major, Sparse matrix - its implementation and usage, Array representation of polynomials, singly linked list - operations, doubly linked list - operations, Circular linked list - operations, Linked list representation of polynomial and applications.

Module III: Stack and Queue

[4L]

Stack and its implementations (using array and linked list), Applications (infix to Postfix, Postfix Evaluation), Queue, circular queue, deque, Implementation of queue - linear and circular (using array and linked list).

Module IV: Recursion

[2L]

Principles of recursion - use of stack, tail recursion, Applications - The Tower of Hanoi, Eight Queens Puzzle.

Module V:Trees

[8L]

Basic terminologies, forest, tree representation (using array and linked list), Binary trees - binary tree traversal(pre-,in-,post-order),Threadedbinarytree,Binarysearchtree-operations(creation,insertion,deletion,searching), Concept of Max-Heap and Min-Heap (creation, deletion), Height balanced binary tree - AVL tree(insertion with examples only), Height balanced binary tree - AVL tree (deletion with examples only), m -WaySearchTree, B+ Tree-operations(insertion,deletion).

ModuleVI:Graphs

[4L]

Graph theory review, Graph traversal and connectivity - Depth-first search (DFS), Breadth-first search (BFS) -concepts of edges used in DFS and BFS (tree-edge, back-edge, cross-edge, and forward-edge), Minimal spanningtree -Prim's algorithm,Kruskal'salgorithm(basicideaofgreedymethods).

Module VII: Searching&Sorting

[8L]

Bubble sort, Insertion sort, Selection sort- with notion of complexity, Quick sort, Merge sort - with complexity,Radixsort-withcomplexity,Sequentialsearch-withcomplexity,Binarysearch,InterpolationSearch-withcomplexity.

ModuleVIII:Hashing

[2L]

IntroductiontoHashingandHashingfunctions,Collisionresolutiontechniques.

Textbooks:

1. "Fundamentals of Data Structures of C" by Ellis Horowitz, Sartaj Sahni, Susan Anderson-freed.

Reference books:

1. "The Art of Computer Programming" by Donald Knuth.
2. "Data Structures, Algorithms, and Software Principles in C" by Thomas A. Standish.
3. "Data Structures" by S. Lipschutz.
4. "Data Structures and Program Design in C, 2nd Edition" by Robert L. Kruse, Bruce P. Leung.
5. "Data Structures in C" by Aaron M. Tenenbaum.

CO-PO-PSO MAPPING

Weightage Values: (3) Strongly matched, (2) Moderately matched, (1) Weakly matched, (-) Not matched.

	PO1	PO2	PO3	PO4	PO5	PO6	PO7	PO8	PO9	PO10	PO11	PO12	PSO1	PSO2	PSO3
CO1	3	3	3	3	2	1	2	1	1	1	2	3	2	3	3
CO2	2	2	3	2	3	-	3	1	1	1	-	3	2	2	3
CO3	2	3	2	2	2	-	1		1	1	-	3	2	3	2
CO4	3	2	2	2	3	-	1	1		1	-	2	2	2	2
CO5	2	2	2	2	1	1	2	1	1	2	2	3	3	3	3
AVG	2.4	2.4	2.4	2.2	2.2	1	1.8	1	1	1.2	2	2.8	2.2	2.6	2.6

Course Name: Circuit Theory & Network

Course Code:EC302

Contact:3:0:0

TotalContactHours:36

Credits:3

Prerequisites: Properties of series and parallel connections, concept of KCL, KVL, complex number,current-voltage phasor diagram, DC and AC, Charging and discharging of capacitor, Energizing anddecayingofinductor.

CourseOutcomes:GraduatesoftheECEprogramwillbeable to:

CO1: Determine current, voltage and power at different branch/node forDC and AC circuit havingindependent&dependentsourceswiththehelpofvariousnetworkstheoremsandmethodslikenodal&meshanalysisandstar-deltatransformation.

CO2:ExplainLaplacetransform ofstepfunction,gatefunction,impulse function,triangular&rectangular function, stain of pulses, initial & final value theorem and able to apply the concept ofLaplacetransformtodetermine thecircuitparametersinS-domain.

CO3:Determineandanalyzecircuitparameters ofRC,RL andRLC networkattransientconditionsintimedomain&S-domainwithDCexcitationsandabletodemonstratetransientbehaviorofRC,RLandRLCcircuitwithACexcitations

CO4: Construct and analyze performance of RLC series & parallel resonance circuit based on theparameters-resonancefrequency,bandwidth,upper & lower cut-off frequency, quality factor andimpedanceatprototypelevelfor audiofrequencyrange.

CO5:DetermineZ,Y,h&Tparameters,analyze&developtwoportequivalentcircuitforanunknownDCandACnetworkwiththe conceptofopen&shortcircuittest.

CO6: Able to determine equivalent inductance, current, voltage, power & energyin a magneticallycoupled

circuit based on the induced polarity of mutual inductance and able to write current & voltage equations from the graph of a circuit with the help of incidence, cut-set & tie-set matrix for a planar network.

Course Content:

Module I: Methods of Analysis and Network Theorems. [10L]

Node and Mesh analysis in DC and AC circuits with independent and dependent sources, supernode & supermesh; Star-Delta transformation technique in DC & AC circuits; Solving problems using network theorems - Superposition theorem, Thevenin's theorem, Norton's theorem, Maximum Power Transfer theorem, Reciprocity theorem in DC & AC circuits with independent and dependent sources; Sinusoidal steady state analysis, complex power.

Module II: Application of Laplace Transform in Circuit Analysis [4L]

Laplace transform: Step function, GATE function, Impulse function, Delta function, Periodic functions - Rectangular & Triangular wave, strain of pulses; initial & final value theorem; Circuit analysis & solution of numerical problems in S-domain.

Module III: Transient Analysis in RC, RL and RLC Circuit [5L]

Transient analysis in RC, RL, RLC circuit with DC excitations - determination of circuit parameters at time ($t=0$, $t=0+$, $t=0-$, $t > 0$) with numerical examples; RC, RL, RLC circuit with sinusoidal excitation (concept only).

Module IV: Resonance in RLC Circuit [4L]

RLC series and parallel resonance circuit - condition of resonance, resonance frequency, impedance & admittance characteristics, quality factor, half power points, bandwidth, phasor diagrams, properties of series and parallel resonance; Solution of problems.

MODULE V: Two Port Network [5L]

Two port network analysis - Z, Y, and ABCD parameters; condition of reciprocity and symmetry in terms of two port parameters; equivalent circuit in terms of Z, Y and h parameters

ers; Interrelation between different two port parameters (concept only); Solutions of circuit problems using two port parameters.

Module VI: Magnetically Coupled Circuit

[4L]

Self & Mutual inductance; Polarity of induced voltage in magnetically coupled circuit; Determination of equivalent inductance in series and parallel magnetically coupled network; Numerical examples for the determination of current, voltage and power of a magnetically coupled network.

Module VII: Graph of a Network

[4L]

Development of graph of a network - planner and non-planner graph, branch, tree, twigs; Incidence Matrix, Cut Set Matrix, Tie Set Matrix for a graph of circuit; Application of graph to solve problems in circuit.

Textbooks:

1. A. Chakrabarti - Circuit Theory: Analysis and Synthesis, Dhanpat Rai & Co.
2. Valkenburg M.E. Van, "Network Analysis", Prentice Hall / Pearson Education
3. Hayt "Engg Circuit Analysis" 6/e Tata McGraw-Hill
4. D. Roy Chowdhury - Networks and Systems, New Age International

Reference Books:

1. B.L. Thereja and A.K. Thereja - A Textbook of Electrical Technology: Basic Electrical Engineering in S. Units (Volume-1), S-Chand
2. Sudhakar: Circuits & Networks: Analysis & Synthesis 2/e TMH
3. D.A. Bell - Electrical Circuits - Oxford
4. P. Ramesh Babu - Electrical Circuit Analysis - Scitech
5. M.S. Sukhija & T.K. Nag Sarkar - Circuits and Networks - Oxford
6. Skilling H.H.: "Electrical Engineering Circuits", John Wiley & Sons.
7. Edminister J.A.: "Theory & Problems of Electric Circuits", McGraw-Hill Co.
8. Kuo F.F., "Network Analysis & Synthesis", John Wiley & Sons.
9. Sivandam - Electric Circuits and Analysis, Vikas

CO-PO-PSO MAPPING:

Weightage Values:3=Stronglymatched,2=Moderately matched,1= Weaklymatched,(-)=Notmatched.

COs	PO1	PO2	PO3	PO4	PO5	PO6	PO7	PO8	PO9	PO10	PO11	PO12	PSO1	PSO2	PSO3
CO1	3	2	2	1	2	1	-	1	2	-	-	2	1	2	-
CO2	3	3	3	2	2	-	1	-	-	2	1	1	2	2	-
CO3	3	3	3	2	1	-	2	-	1	-	-	3	3	3	-
CO4	3	3	2	3	2	-	-	2	-	-	1	3	3	1	-
AVG	3	2.75	2.5	2	1.75	1	1.5	1.5	1.5	2	1	2.25	2.25	2	-

CourseName:Electronic Devices

Course Code: EC303

Contact:3:0:0

TotalContactHours:36

Credits:3

Prerequisites: Electronic structure of atoms, crystalline and non-crystalline solids, unit cells, Miller index, conductors, semiconductors and insulators, electrical properties, basic concept of electronic devices.

CourseOutcomes:GraduatesoftheECEprogramwillbeable to:

CO1: Understand the Energy band diagram, charge carrier transport phenomenon, recombination generation process of different types of semiconductor materials.

CO2: Illustrate rectifying properties of different types of junction diode.

CO3: Understand the Characteristics & Current flow of semiconductor devices like BJT, JFET, MOSFET & Metal-Semiconductor Junction & Hetero Junction Devices.

CO4: Analyze the design parameters of MOSFET i.e. - Channel length & width, depletion width, surface field and potential, ON resistance, trans conductance, equivalent circuits, amplification factors, capacitances, noise margins, scaling & short channel effects MOSFET.

CO5: Study the concepts of both positive and negative feedback and the concept of OP-AMP in electronic circuits.

CO6: Understand the importance of reverse current in solar cells & LED.

Course Contents:**Module I: Charge Carriers in Semiconductors:****[6L]**

Introduction to semiconductor physics: review of quantum mechanics, electrons in periodic lattices, E-k diagrams. Energy bands in intrinsic and extrinsic silicon; intrinsic & extrinsic semiconductor. Effect of temperature and energy gap on intrinsic concentration, effect of temperature on extrinsic semiconductor, derivation of equilibrium electron and hole concentration in terms of effective density of states and intrinsic level, derivation of electron and hole concentration in a compensated semiconductor, basic concept on optical absorption, photoluminescence, carrier lifetime, carrier generation and recombination, continuity equation (expression and significance only). Degeneracy and non-degeneracy of semiconductors.

Non-equilibrium condition: Effect of temperature and doping concentration on mobility, Effective mobility due to scattering effect, drift & diffusion of carriers, high field effect on drift velocity, Hall effect and piezoelectric effect, generation and recombination, quasi-Fermi energy level (concept only).

Module II: P-N Junction Diode:**[8L]**

P-N junction formation and depletion region, energy band diagram of p-n junction at equilibrium and barrier energy, built-in potential at p-n junction, energy band diagram and current through p-n junction at forward and reverse bias, V-I characteristics and current expression of diode, temperature dependencies of V-I characteristics of diode, p-n junction breakdown – conditions, avalanche and Zener breakdown, Concept of Junction capacitance, Zener diode and characteristics.

Diode half wave and full wave rectifiers circuits and operation (IDC, Irms, VDC, Vrms, ripple factor without filter, efficiency, PIV, TUF; Reduction of ac ripples using filter circuit (Qualitative analysis); Design of diode clipper and clamper circuit - explanation with example, application of Zener diode in regulator circuit. Numerical problems

Module III: Device Physics of Bipolar Junction Transistor:**[6L]**

Physical mechanism, carrier distribution in forward active mode, terminal current equations, common base current gain (α), common emitter current gain (β), controlling parameters for β , punch-through and avalanche effect, expression for punch through voltage and avalanche breakdown voltage (no derivation), Solution of continuity equation and Poisson's equation for BJT, Eber's Moll model for Static behavior & Charge controlled model (without derivation) for dynamic behavior, equivalent circuits, origin of parameters in hybrid- π model, time delay factors in BJT, alpha and beta cut-off frequency, idea of phototransistor. Numerical Problems.

Module IV: Field Effect Transistors:**[6L]**

JunctionFieldEffectTransistor(JFET):

Construction,fieldcontrolactionandI-Vcharacteristics,JFETparameters,Schokleyequation,NumericalProblems.

MetalOxideFieldEffect Transistor(MOSFET):

Typesof MOSFET ,structure of E-MOSFET,MOSstructure under externalbias-accumulation,depletionandinversionphenomenonwithenergybanddiagram,thresholdvoltageandflatbandvoltage; working of E-MOSFET with characteristics ;drain current equation for linear and saturationregion with condition (expression only); channel length modulation ;derivation of threshold voltage ofidealandnon-idealMOSFETCapacitance-DifferenttypesofMOSFETCapacitances,MOScapacitancevariationwithgatetosourcevoltageunderlowfrequency&HighFrequency; largeandsmallsignalmodel of MOSFET(explanation withdiagram). BasicofMESFET,NumericalProblems.

ModuleV:FeedbackandOperationalAmplifier

[6L]

Conceptoffeedbackwithblockdiagram,positiveandnegativefeedback,gainwithfeedback.Feedbacktopologies,effectoffeedbackoninputandoutputimpedance,distortion,conceptofoscillationandBarkhausencriterion.

Operational amplifier – electrical equivalent circuit, ideal characteristics, non-ideal characteristics ofop-amp–offsetvoltages;biascurrent;offsetcurrent;Slewrate;CMRRandbandwidth,Configuration of inverting and non-inverting amplifier using Op-amp, closed loop voltage gain ofinverting and non- inverting amplifier, Concept of virtual ground, Applications op-amp – summingamplifier;differentialamplifier;voltage follower;basicdifferentiator andintegrator.

Problems on Characteristics of Op-amp, CMRR, slew rate, amplifier, and application of Op-amp to bediscussed.Anyotherrelevantproblemsrelatedtotopicmaybediscussedor assigned.

Module VI:**[4L]****Photo Devices:**

Solar cell – photo-voltaic effect, constructional features of solar cell, conversion efficiency and fill factor; LED; Basic idea about Photo Diode. Numerical Problems.

Hetero Junction

Energy band diagram, Classification of Heterojunction; 2D Electron Gas (Isotype Heterojunction), n-isotype Heterojunction, I-V Characteristics.

extbooks:

1. Streetman & Banerjee - Solid State Electronic Devices, PHI.
2. S.M. Sze, Physics of semiconductor devices, Wiley.

Reference Books:

1. Milman, Halkias – Integrated Electronics – TMH.
2. Sedra & Smith - Microelectronic Circuits - Oxford.
3. Neamen - Semiconductor Physics and Devices TMH.
4. S.M. Kang and Y. Leblebici. - CMOS Digital Integrated Circuits, Tata McGraw-Hill.

CO- PO Mapping:

COs	PO1	PO2	PO3	PO4	PO5	PO6	PO7	PO8	PO9	PO10	PO11	PO12	PSO1	PSO2	PSO3
CO1	3	2	2	1	2	2	-	-	-	-	2	2	-	-	-
CO2	3	3	3	2	2	2	-	-	-	-	1	2	2	-	-
CO3	3	3	3	2	1	2	-	-	-	-	2	3	-	-	-
CO4	3	3	2	3	2	2	-	-	-	-	1	3	1	-	-
CO5	3	3	3	2	1	2					2	3	-	-	-
CO6	3	2	2	1	2	2					1	3	-	-	-
AVG	3	2.7	2.5	1.8	1.7	2					1.5	2.7	1.5		

Weightage Values: 3 = Strongly matched, 2 = Moderately matched, 1 = Weakly matched, (-) = Not matched.

Course Name: Signals & Systems

Course Code: EC304

Contacts: 3:0:0

Total Contact Hours: 36

Credits: 3

Course Objectives:

To explain the basic properties of signal & systems and the various methods of classification. To define Fourier series, Fourier transform, and Z transform and their properties

To illustrate LTI systems and random process.

Course Outcome:

Graduates of the ECE program will be able to:

CO 1: Identify different signals and systems and state their properties both in Continuous and discrete time domain.

CO 2: Apply the concept of impulse response and perform convolution in both Continuous and discrete domain to analyze the LTI systems.

CO 3: Compute spectral analysis of signals using Fourier series, Fourier transform, and Z-transform techniques.

CO 4: Demonstrate the application of sampling theorem and concepts of random processes.

CO 5: The graduates should learn mathematics, basic knowledge of differential equations and difference equations.

Module-1:

[15L

]

Introduction to signals and systems:

[6L]

Continuous and discrete time signals: Definition and Classification of signals, Types of sampling, Sampling theorem, Reconstruction of a Signal from its samples, Definitions and Numerical on Unit step, Unit Impulse, Unit Ramp, Definitions of Exponential and Sinusoid both for continuous and discrete, Rectangular Pulse function, Triangular pulse function, Signum function, Sync function,

Gaussian function. Representation of signals using graphical, tabular, and sequential form, Operations on signals.

LTI systems:

Definition, Relationship between LTI system properties and Impulse Response.

[1L]

] Classification and convolution of Signals: Definitions and numerical of Periodic & Aperiodic signals, Even & Odd signals, Energy & Power signals, Deterministic & Random signals, Causal, Anti causal and non causal signals, convolution of two signals using graphical and matrix method.

[3L]

] Systems and its classifications: Definition of systems and its representation, Definition and numerical of Linear & Non-linear system, Causal & non causal system, Time variant & invariant system, Stability of the system, Systems with memory and without memory, Invertible and noninvertible Systems. Examples of discrete-time system model.

[3L]

]

Correlation of Two Sequences:

Cross-correlation, Auto-correlation, Computation of correlation, Correlation of power and periodic signals.

[2L]

]

Module-II:

Fourier series of Continuous-time and Discrete-time Signals

[6L]

Fourier series analysis & Derivation of Fourier Coefficients Equation (Exponential form only), Fourier Series Properties, Symmetry Properties of the Fourier Series, Diminishing of Fourier Coefficients, Dirichlet Conditions, Fourier Spectrum, Gibbs's Phenomena, Parseval's relation (statement only), Problems on Fourier series & Basic concept of Discrete time Fourier series.

[6L]

Module-III:

Signal Transformation

[6L]

Introduction to Continuous time Fourier Transform (CTFT):

Definition, Importance, Relation with Fourier series, Examples, Computation of Fourier transform of different signals. [2L]

Properties of Fourier Transform

Linearity, Time shifting, Conjugation, Differentiation, Integration, Time scaling, Parseval's theorem, Duality,

Convolution.[1L]

Discrete time Fourier Transform(DTFT):

Introduction, Definition, Computation of DTFT of different sequences.[1L]

Linear Phase systems, Ideal filters, Signal Bandwidth, Relationship between bandwidth and Rise Time.[2L]

Module IV Z-Transforms

[6L]

Introduction to Z-Transforms: Definition, Relationship between Fourier transform and Z- transform, Region of convergence (ROC), Properties of ROC, Properties of Z-transform, transfer function, concept of Poles and zeroes, Z-transform of different sequences.[4L]

Inverse Z-transform:

Inverse Z-transform using residue theorem, power series expansion and partial fraction method.[2L]

Module V

Introduction to Random Variables[3L]

Definition of Random Signal, Random Variables and Probability Distributions, Examples.[1L]

Statistical Properties of Random Signal: Independent and conditional random variables, Standard Deviation, mean, variance, Examples. [1L]

Independent and Dependent Random Variables, Arithmetic Mean. [1L]

Textbooks:

Linear Signals and Systems by B.P.Lathi-OXFORD University Press

Signals & Systems by A.V.Oppenheim, A.S.Willsky and S.H.Nawab - Pearson
Signals and Systems by P.Ramesh Babu & R.Anandanatarajan - Scitech
References:

Signals & Systems by A.AnandKumar-PHI

Signals and Systems by S.Haykin & B.V.Veen-John Wiley
Signals and Systems by A.Nagoor Kani-McGraw

Hill
Signals and Systems by S.Ghosh-Pearson

Digital Signal Processing by M.H.Hays-TMH
Signals and Systems by Salivahanan

Signals and Systems with MATLAB by Wön-yōng Yang-Springer

Signals and Systems by A.Nagoor Kani-McGraw Hill

Digital Signal Processing by P.Ramesh Babu & R.Anandanatarajan-Scitech

Mapping of CO with PO:

Weightage Values: 3 = Strongly matched, 2 = Moderately matched, 1 = Weakly matched, (-) = Not matched.

	PO1	PO2	PO3	PO4	PO5	PO6	PO7	PO8	PO9	PO10	PO11	PO12	PSO1	PSO2	PSO3
CO1	3	3	3	3	2		2		3			3	3	2	2
CO2	3	3	3	3	2	2	2		3		2	3	3	2	2
CO3	3	3	3	3	2		2		3	2		3	3	2	2
CO4	3	3	3	3	2		2	2	3			3	3	2	1
CO5	2	3	3	3	2		2		3			3	3	1	1
AVG	2.8	3	3	3	2	2	2	2	3	2	2	3	3	1.8	1.6

CourseName:UniversalHumanValues2:UnderstandingHarmony

Course Code:HSMC 303

Contacts:3:0:0

TotalContactHours:36

Credit:3

Prerequisite:None

Course Outcomes: On successful completion of the learning sessions of the course, the graduates of theECEprogramwillbe able to:

CO1:Develop holistic perspective based on self-exploration aboutthemselves (humanbeing), family,societyandnature/existence.

CO2:Cultivatetheharmonyinthehumanbeing,family,societyand nature/existence.

CO3:Strengthenself-reflection.

CO4:Buildcommitmentandcouragetact.

CourseContent:

Module-1: Course Introduction - Need, Basic Guidelines, Content and Process for ValueEducation

[8L]

Self-Exploration–whatisit?-Itscontentandprocess;‘NaturalAcceptance’andExperientialValidation- as the process for self-exploration. Continuous Happiness and Prosperity- A look at basicHuman Aspirations. Right understanding, Relationship and Physical Facility- the basic requirementsforfulfilmentofaspirationsofeveryhumanbeingwiththeircorrectpriority.UnderstandingHappiness and Prosperity correctly- A critical appraisal of the current scenario. Method to fulfil theabove human aspirations: understanding and living in harmony at various levels. Practice sessions todiscuss natural acceptance in human being as the innate acceptance for living with responsibility (living inrelationship,harmony,andco-existence)rather thanasarbitrarinessinchoicebasedonliking-disliking.

Module-2: Understanding Harmony in the Human Being - Harmony in Myself:

[

6L]

Understanding human being as a co-existence of the sentient 'I' and the material 'Body'. Understanding the needs of Self ('I') and 'Body' - happiness and physical facility. Understanding the Body as an instrument of 'I' (I am being the doer, seer, and enjoyer). Understanding the characteristics and activities of 'I' and harmony in 'I'. Understanding the harmony of I with the Body: Sanyam and Health; correct appraisal of Physical needs, meaning of Prosperity in detail.

Programs to ensure Sanyam and Health. Practice sessions to discuss the role others have played in making material goods available to me. Identifying from one's own life. Differentiate between prosperity and accumulation. Ensuring health vs dealing with disease discussion.

Module-3:**Understanding Harmony in the Family and Society - Harmony in Human Relationship:**

[

7L]

Understanding values in human-human relationship; meaning of Justice (nine universal values in relationships) and program for its fulfilment to ensure mutual happiness; Trust and Respect as the foundational values of relationship. Understanding the meaning of Trust; Difference between intention and competence. Understanding the meaning of Respect, Difference between respect and differentiation; the other salient values in relationship. Understanding the harmony in the society (society being an extension of family): Resolution, Prosperity, fearlessness (trust) and co-existence as comprehensive Human Goals. Visualizing a universal harmonious order in society - Undivided Society, Universal Order - from family to world family. Practice sessions to reflect on relationships in family, hostel and institute as extended family, real life examples, teacher-student relationship, goal of education etc. Gratitude as a universal value in relationships. Elicit examples from students' lives.

Module-4:**Understanding Harmony in the Nature and Existence -****Whole existence as Coexistence:**

[8

L]

Understanding the harmony in the Nature. Interconnectedness and mutual fulfilment among the four orders of nature- recyclability and self- regulation in nature. Understanding Existence as Co-existence of mutually interacting units in all-pervasive space. Holistic perception of harmony at all levels of existence. Practice sessions to discuss human being as cause of imbalance in nature (film “Home” can be used), pollution, depletion of resources and role of technology etc.

Module-5:

Implications of the above Holistic Understanding of Harmony on Professional Ethics:

[7

L] Natural acceptance of human values. Definitiveness of Ethical Human Conduct. Basis for Humanistic Education, Humanistic Constitution and Humanistic Universal Order.

Competence in professional ethics:

- a) Ability to utilize the professional competence for augmenting universal human order
- b) Ability to identify the scope and characteristics of people-friendly and eco-friendly production systems,
- c) Ability to identify and develop appropriate technologies and management patterns for above production systems.
- d) Case studies of typical holistic technologies, management models and production systems. Strategy for transition from the present state to Universal Human Order:
- e) At the level of individual: as socially and ecologically responsible engineers, technologists, and managers
- f) At the level of society: as mutually enriching institutions and organizations.
- g) Practice Exercises and Case Studies in Practice (tutorial) Session to discuss the conduct as an engineer or scientist etc.

Textbooks:

1. Human Values and Professional Ethics by RRGaur, RSangal, GPBagaria, Excel Books, New Delhi, 2010

Reference Books:

1. Jeevan Vidya: Ek Parichaya, ANagaraj, Jeevan Vidya Prakashan, Amarkantak, 1999.
2. Human Values, A.N. Tripathi, New Age Intl. Publishers, New Delhi, 2004.
3. The Story of Stuff (Book).

4. TheStoryofMyExperimentswithTruth-byMohandasKaramchand Gandhi
5. SmallisBeautiful-E.FSchumacher.
6. SlowisBeautiful-CecileAndrews
7. EconomyofPermanence- JCKumarappa
8. Bharat MeinAngrejiRaj-PanditSunderlal
9. RediscoveringIndia-byDharampal
10. HindSwarajor IndianHomeRule-byMohandasK.Gandhi
11. IndiaWinsFreedom-Maulana AbdulKalamAzad
12. Vivekananda-RomainRolland(English)
13. Gandhi-RomainRolland(English)

CO-POMapping:

CO	PO1	PO2	PO3	PO4	PO5	PO6	PO7	PO8	PO9	PO10	PO11	PO12	PSO1	PSO2	PSO3
CO1						1	-	-	-	2	3	3	1	-	
CO2						2	-	1	2	-	3	3	2	-	
CO3						3	1	-	2	1	3	3	1	1	
CO4						-	-	2	-	3	3	3	2	-	
AVG						2	1	1.5	2	2	3	3	1.5	1	

WeightageValues:3= Stronglymatched, 2=Moderatelymatched, 1 =Weaklymatched,(-)= Notmatched.

Course Name: Numerical Methods Lab

Course Code: M (CS)391

Contact: 1:0:3

Credits: 2.5

Prerequisites: Any introductory course on programming language (example C/Matlab).

Course Outcome(s):

On successful completion of the learning sessions of the course, the Graduates of the ECE program will be able to:

CO1: Understand the theoretical workings of numerical techniques with the help of C/Matlab

CO2: Execute basic commands and scripts in a mathematical programming language

CO3: Apply the programming skills to solve the problems using multiple numerical approaches.

CO4: Analyze if the results are reasonable, and then interpret and clearly communicate the results.

List of Experiment:

1. Assignments on Newton forward /backward, Lagrange's interpolation.
2. Assignments on numerical integration using Trapezoidal rule, Simpson's 1/3 rule.
3. Assignments on numerical solution of a system of linear equations using Gauss elimination, Tridiagonal matrix algorithm, Gauss-Seidel iterations. LU Factorization method.
4. Assignments on numerical solution of Algebraic Equation by Bisection method, Regula-Falsi method, Secant Method, Newton-Raphson method.
5. Assignments on ordinary differential equation: Euler's method, Euler's modified method, Runge-Kutta methods, Taylor series method and Predictor-Corrector method.

Implementation of numerical methods on computer through C/C++ and commercial Software

Packages: Matlab / Scilab / Labview / Mathematica/NAG (Numerical Algorithms Group)/Python.

CO-PO Mapping:

Weightage Values:(3)Stronglymatched,(2)Moderatelymatched,(1)Weaklymatched,(-)Not matched.

	PO1	PO2	PO3	PO4	PO5	PO6	PO7	PO8	PO9	PO10	PO11	PO12	PSO1	PSO2	PSO3
CO1	3	2	1	-	-	-	-	-	-	-	-	1	-	-	2
CO2	3	2	2	-	-	-	-	-	-	-	-	1	1	-	-
CO3	3	2	2	-	-	-	-	-	-	-	-	2	1	2	-
CO4	3	3	2	3	-	-	-	-	-	-	-	1	3	1	
AVG	3	2.25	1.75	3	-	-	-	-	-	-	-	1.25	1.67	1.5	2

Course Name: Data Structures Lab

CourseCode:EC391

Contacts:0:0:3

Credits:1.5

Prerequisites: Fundamentals of Computer & C Programming

Course Outcome:

Upon the completion of the course the students will be able to

CO1: Understand the theoretical workings of numerical techniques with the help of C/ Matlab.

CO2: Execute basic command and scripts in a mathematical programming language.

CO3: Able to apply searching, sorting algorithms.

CO4: Able to apply graph theory and hash function

CourseContent:

1. Write a C program that uses functions to perform the following:
 - a. Create a singly linked list of integers.
 - b. Delete a given integer from the above linked list.
 - c. Display the contents of the above list after deletion.

2. Write a C program that uses functions to perform the following:
 - a. Create a doubly linked list of integers.
 - b. Delete a given integer from the above doubly linked list.
 - c. Display the contents of the above list after deletion.

3. Write a C program to implement Polynomial addition and Polynomial multiplication using Linked List.

4. Write a C program that uses stack operations to convert a given infix expression into its postfix Equivalent, Implement the stack using an array.

5. Write C programs to implement a queue ADT using (i) array and (ii) doubly linked list respectively.

6. Write a C program that uses functions to perform the following:
 - a. Create a binary search tree of characters.
 - b. Traverse the above Binary search tree recursively in Post order.

7. Write a C program that uses functions to perform the following:
 - a. Create a binary search tree of integers.
 - b. Traverse the above Binary search tree non-recursively in order.

8. Write C programs for implementing the following sorting methods to arrange a list of integers in ascending order:
 - a. Insertion sort.
 - b. Merge sort.

9. Write C programs for implementing the following sorting methods to arrange a list of integers in ascending order:
 - a. Quick sort.
 - b. Selection sort.

10. Write C programs for implementing the following searching methods:
 - a. Linear Search.
 - b. Binary Search.

11. Write a C program to implement all the functions of a dictionary (ADT) using hashing.

12. Write C programs for implementing the following graph traversal algorithms:

- a. Depth first search.
- b. Breadth first search.

CO-PO-PSO Mapping:

Weightage Values: (3) Strongly matched, (2) Moderately matched, (1) Weakly matched, (-) Not matched.

	PO1	PO2	PO3	PO4	PO5	PO6	PO7	PO8	PO9	PO10	PO11	PO12	PSO1	PSO2	PSO3
CO1	3	1	3	3	-	-	-	-	3	-	-	3	3	2	1
CO2	3	2	3	1	-	-	-	-	3	-	-	-	1	-	2
CO3	1	3	3	2	-	-	-	-	3	-	-	2	1	2	3
CO4	2	1	3	1	-	-	-	-	3	-	-	-	1	-	1

Course Name: Circuit Theory and Networks Lab

Course Code: EC392

Contact: 0:0:3

Credit:1.5

Prerequisites: Concept of series and parallel connections, concept of KCL,KVL, circuit with electrical components,DC,and AC source

Course Outcomes:

Upon the completion of the course the students will be able to

CO1: Understand current, voltage and power in a DC and AC circuit with the help of network Theorems, Superposition theorem, Thevenin's & Norton's theorem, Maximum power transfer theorem, Compensation theorem and Millman's theorem.

CO2: Measure Z, Y, h & ABCD parameters of a two-port network following open circuit and short circuit test and conclude whether the network is symmetrical or reciprocal or both.

CO3: Construct RLC series & parallel resonance circuit and analyze its performance through the determination of resonance frequency, bandwidth, upper & lower cut-off frequency, quality factor and impedance at audio frequency range.

CO4: Estimate transient & steady state value of current & voltage in RC, RL & C circuit with DC excitations range upto 25 V from the transient response curve.

List of Experiments:

1. Verification of Superposition theorem, Thevenin's Theorem, Norton's Theorem. [6P]
2. Study of maximum power transfer theorem [3P]
3. Study of Compensation theorem and Millman's theorem. [3P]
4. Determination of Z & Y parameters of a two-port network. [3P]
5. Determination of h & ABCD parameters of two-port networks. [6P]
6. Study of series RLC resonance circuit. [3P]
7. Study of Parallel RLC resonance circuit. [3P]
8. Transient response in RC circuit. [3P]

8. TransientresponseinRLcircuit.[3P]
9. TransientresponseinRLCircuit.[3P]
10. Innovativeexperiment.

CO-PO-PSO Mapping:

	PO1	PO2	PO3	PO4	PO5	PO6	PO7	PO8	PO9	PO10	PO11	PO12	PSO1	PSO2	PSO3
CO1	3	3	3	2	3	-	-	-	3	2	-	3	3	-	-
CO2	3	3	2	2	3	-	-	-	3	2	-	3	1	-	-
CO3	3	3	3	2	3	-	-	-	3	2	-	3	3	2	-
CO4	3	3	3	3	3	-	-	-	3	2	-	3	3	1	-

Weightage Values: 3= Strongly matched, 2=Moderately matched, 1 =Weakly matched, (-) = Not matched.

Course Name: Electronics Devices Lab

Course Code: EC393

Contact: 0:0:3

Credits: 1.5

Course Outcome:

Upon the completion of the course the students will be able to

CO 1: Understand the working of different diodes, transistors, CRO probes and measuring instruments. Identifying the procedure of doing the experiment.

CO 2: Understand the characteristics of BJT and FET and how to determine different parameters for designing purpose.

CO 3: Verify properties of photoelectric devices

CO 4: Measure and record the experimental data, analyze the results, and prepare a formal laboratory report.

Course Contents:

1. Identifying and study of different components like resistor, capacitors, diodes, LED, Transistors, FET (JFET & MOSFET) etc.

2. Study of different instruments used in the laboratories like, power supply, Oscilloscope, Multi-meter etc.

3. **Characteristics Of PN Junction Diode:**

a) To Plot the Volt Ampere Characteristics of PN Junction Diode under Forward and Reverse Bias Conditions.

b) To find the Cut-in voltage, Static Resistance, Dynamic Resistance for Forward Bias & Reverse Bias.

4. **Characteristics Of Zener Diode & Load Regulation:**

a) To Obtain the Forward Bias and Reverse Bias characteristics of a Zener diode.

b) Find out the Zener Breakdown Voltage from the Characteristics.

c) To Obtain the Load Regulation Characteristics.

5. **Common Base Bipolar Transistor Characteristics:**

To plot the Input and Output characteristics of a transistor connected in Common Base Configuration and to find the parameters from the characteristics.

6. Common Emitter Bipolar Transistor Characteristics:

ToplottheInputandOutputcharacteristicsof atransistorconnectedinCommonEmitterConfigurationandtofind theh– parametersfromthecharacteristics

7. DesignSelfBias BJTCircuit.

8. J-FET Drain & Transfer Characteristics (Common Source):

a) Drain characteristics

b) Transfer Characteristics.

c) To find r_{ds} , g_m , and μ from the characteristics.

9. Study Characteristics of Phototransistor.

10. Study Characteristics of LED & LDR.

CO-PO-PSO Mapping:

	PO1	PO2	PO3	PO4	PO5	PO6	PO7	PO8	PO9	PO10	PO11	PO12	PSO1	PSO2	PSO3
CO1	3	3	3	3	-	-	-	-	3	2	-	1	3	-	-
CO2	3	3	2	3	-	-	-	-	3	2	-	2	3	1	-
CO3	3	3	2	3	-	-	-	-	3	2	-	1	3	-	-
CO4	3	3	3	3	-	-	-	-	3	2	-	2	3	-	-

Weightage Values: 3= Strongly matched, 2 =Moderately matched, 1 =Weakly matched, (-)= Not matched.

Stream: ECE
Subject Name: Theme based Project III
Subject Code: PR391
Contact hour: 1P
Total contact hour- 10

Credits: 0.5
Prerequisite: Course completed up to 2nd semester in UG ECE

Course Objective:

Prepare students with foundation knowledge in a project domain through surveying, designing, implementing, observing and reporting.

Methodology:

1. Thinking: Discussion on innovative idea.
2. Exploring: Survey of recent research.
3. Implementing: Project guidance to basic prototype implementation.
4. Documenting: Guidance on reporting and conference paper writing.
5. Each Theme based Project III group should submit the following under their semester project report submission with topics not limited to,

Title, certificates, declaration by student, acknowledgement, Table of Contents, abstract, keywords, Introduction, Literature Survey, System Analysis (if applicable), System Design (if applicable), Coding, Testing (if applicable), Conclusion, Future Scope of work), reference

Course outcome:

Sem. No.	Course Title (Code)	CO Codes	Course Outcomes
			On completion of the course students will be able to
3 rd	Theme based Project III (PR391)	CO.PR391.1	Apply the knowledge acquired through survey of recent research to set the project goal.
		CO.PR391.2	Distinguish the way of implementation of prototype
		CO.PR391.3	Identify the fault issue through various case study
		CO.PR391.4	Implement the prototype using modern tools

CO-PO-PSO MAPPING:

	PO1	PO2	PO3	PO4	PO5	PO6	PO7	PO8	PO9	PO10	PO11	PO12	PSO1	PSO2	PSO3
CO1	3	3	3	2	1	1	3		1	1		3	2	3	
CO2	3	3	3	3	3			3	3		2	3	3	3	2
CO3	2		3	3	2	2	3	3	2	2		3	3	2	1
CO4	1	3	3	2	3		3	2	3		2	3	3	3	3
AVG	2.25	3	3	2.5	2.25	1.5	3	2.67	2.25	1.5	2	3	2.75	2.75	2

Stream: ECE

Subject Name: Skill Development III: Technical Seminar Presentation

Subject Code: PR392

Contact hour: 1

Total contact hour- 10

Credits: 0.5

Prerequisite: Course completed up to 2nd semester in UG ECE

Objectives:

1. To show competence in identifying relevant information, defining and explaining topics under discussion. To build depth of understanding, using primary and secondary sources.
2. To use appropriate registers and vocabulary, demonstration command with voice modulation, voice projection, and pacing.
3. To use of visual, audio and audio-visual material to support presentation
4. To speak cogently with or without notes, present either in groups or as individuals.

Course outcome:

Sem. No.	Course Title (Code)	CO Codes	Course Outcomes
			On completion of the course students will be able to
3 rd	Skill Development III: Technical Seminar Presentation (PR392)	CO.PR392.1	Show competence in identifying relevant information, defining and explaining topics under discussion.
		CO.PR392.2	Demonstrate command of voice modulation, voice projection, and pacing.
		CO.PR392.3	Judge when to speak and how much to say, speak clearly and audibly in a manner appropriate to the subject
		CO.PR392.4	Ask appropriate questions, use evidence to support claims, respond to a range of questions,
		CO.PR392.5	Take part in meaningful discussion to reach a shared understanding
		CO.PR392.6	Speak cogently with or without notes and present either in groups or as individuals.

CO-PO-PSO MAPPING:

	PO1	PO2	PO3	PO4	PO5	PO6	PO7	PO8	PO9	PO10	PO11	PO12	PSO1	PSO2	PSO3
CO1	3	2	3		1	1	3		1	1		3	2	3	
CO2	3	3	3	2	3			3	3		2	3	3	3	2
CO3	3	3	2	1	2	2	3	3	2	2		3	3	2	1
CO4	3	3	3	3	3		3	2	3		2	3	3	3	3
CO5	3	3	3	2	3	2		3	3	2		3	3	3	2
AVG	3	2.8	2.8	2	2.4	1.67	3	2.75	2.4	1.67	2	3	2.8	2.8	2

Course Name: ENVIRONMENTAL SCIENCE

Course Code: MC301

Contacts: 3:0:0

Total Contact Hours: 36

Credits: 0

Course Outcomes:

Graduates of the ECE program will be able to:

CO1: Understand the natural environment and its relationships with human activities.

CO2: Apply the fundamental knowledge of science and engineering to assess environmental and health risk.

CO3: Develop guidelines and procedures for health and safety issues obeying the environmental laws and regulations.

CO4: Acquire skills for scientific problem-solving related to air, water, noise & land pollution.

Course Contents:

Module 1: General

[11L]

Natural Resources: Forest Resource, water resource, mineral resource, energy resources: alternative source of energy

Population Growth: Exponential Growth, logistic growth, Maximum sustainable yield, demography
Disaster Management: Types of disasters (Natural & Man-made), Floods, Earthquake, Tsunamis, Cyclones, landslides (cause, effect & control)

Ecology & Ecosystem: Elements of ecology, definition of ecosystem - component types and function, Food chain & Food web, Structure, and function of the following ecosystem: Forest ecosystem, Grassland ecosystem, Desert ecosystem, Aquatic ecosystems

Environmental Management: Environmental impact assessment, Environmental laws and protection act of India (The Environment protection Act, Air pollution Act, Water Act, Wildlife Protection Act), Hazardous waste (management and Handling) Rules.

Module 2: Air pollution and control

[10L]

Sources of Pollutants: point sources, non-point sources and man-made sources primary & secondary pollutant

Types of air pollutants: primary & secondary pollutant; Suspended particulate matter, oxides of carbon, oxides of nitrogen, oxides of Sulphur, particulate, PAN, Smog (Photochemical smog and London smog),

Effects on human health & climate: Greenhouse effect, Global Warming, Acid rain, Ozone Layer Depletion

Air pollution and meteorology: Ambient Lapse Rate, Adiabatic Lapse Rate, Atmospheric stability & Temperature inversion control of air pollution (ESP, cyclone separator, bag house, catalytic converter, scrubber (venturi)).

Module 3: Water Pollution

[9L]

Classification of water (Ground & surface water)

Pollutants of water, their origin and effects: Oxygen demanding wastes, pathogens, nutrients, Salts, heavy metals, pesticides, volatile organic compounds.

Surface water quality parameters: pH, DO, 5-day BOD test, BOD reaction rate constants, COD. Numerical related to BOD

Lake: Eutrophication [Definition, source and effect].

Groundwater: Aquifers, hydraulic gradient, groundwater flow (Definition only), groundwater pollution (Arsenic & Fluoride; sources, effects, control).

Quality of Boiler feed water: DO, hardness, alkalinity, TDS and Chloride.

Layout of wastewater treatment plant (scheme only). Module 4: Land Pollution

[3L]

Types of Solid Waste: Municipal, industrial, commercial, agricultural, domestic, hazardous solid wastes (bio-medical), E-waste

Solid waste disposal method: Open dumping, Land filling, incineration, composting, recycling (Advantages and disadvantages).

Waste management: waste classification, waste segregation, treatment & disposal

Module 5: Noise Pollution

[3L]

Definition of noise, effect of noise pollution on human health, Average Noise level of some common noise sources

Definition of noise frequency, noise pressure, noise intensity, noise threshold limit value, equivalent noise level, L_{10} (18 hr. Index). Noise pollution control.

Textbook:

A Textbook of Environmental Studies, Shashi Chawla. Tata McGraw Hill Education Private Limited
References Books:

Environmental Studies, Dr. J P Sharma, University Science
 Press.EnvironmentalEngineering,J.K.DasMohapatra,VikasPublication.

CO-PO Mapping:

COs	PO1	PO2	PO3	PO4	PO5	PO6	PO7	PO8	PO9	PO10	PO11	PO12	PSO1	PSO2	PSO3
CO1	2	2	-	-	-	3	3	-	-	-	-	-	-	-	-
CO2	1	2	-	-	-	3	3	-	-	-	-	1	-	-	-
CO3	2	2	3	1	-	3	3	-	-	-	-	-	-	-	-
CO4	3	1	3	1	3	3	3	-	-	-	-	-	-	-	-

Weightage Values: 3 = Strongly matched, 2 = Moderately matched, 1 = Weakly matched, (-) = Notmatched.

R21(B.TechECE)**CurriculumforB.Tech****UnderAutonomy****Electronics&CommunicationEngineering****(EffectiveFrom2021-22admissionBatch)****L–Lecture;T-Tutorial;P-Practical[1L=1Cr,1T=1Cr,1P=0.5Cr]****2ndYear2ndSemester:4thSemester**

Sl. No.	Category	CourseCode	CourseTitle	Hoursperweek				Credits/Unit
				L	T	P	Total	
A.THEORY								
1	PC	EC401	EMTheory& Antenna	3	0	0	3	3
2	PC	EC402	AnalogCircuits	3	0	0	3	3
3	PC	EC403	DigitalElectronics	3	0	0	3	3
4	PC	EC404	Analog& DigitalCommunication	3	0	0	3	3
5	PC	EC405	DigitalSignalProcessing	3	0	0	3	3
6	HSMC	HSMC 402	Gender Culture and Development	2	0	0	2	2
B.PRACTICAL								
6	PC	EC491	EMTheory& AntennaLab	0	0	3	3	1.5
7	PC	EC492	AnalogCircuitsLab	0	0	3	3	1.5
8	PC	EC493	DigitalElectronicsLab	0	0	3	3	1.5
9	PC	EC494	Analog& DigitalCommunicationLab	0	0	3	3	1.5
10	PC	EC495	DigitalSignalProcessingLab	0	0	3	3	1.5
11	PROJECT	PR491	Themebased ProjectIV	0	0	1	1	0.5

12	PROJECT	PR492	Skill Development IV:SoftSkill& Aptitude	0	0	1	1	0.5
C.MANDATORYACTIVITIES/COURSES								
13	MC	MC481	Learning an Art Form [vocal orinstrumental,dance,painting,claymodeling,etc.] OR EnvironmentalProtectionInitiatives	0	0	2	2	0
TOTALCREDITWITHOUTMOOCSCOURSES								25.5
D.MOOCSCOURSES								
14	MOOCS COURSES	HM401	MOOCSCOURSE-III	3	1	0	4	4
TOTALCREDITWITHMOOCSCOURSES(FORCSE,ECE,EE,EIE)								29.5

****MOOCSCOURSESforHONOURS/MINORDegreearereProgramspecificandtotobetakenfromMOOCBASKET**

Course Name: EM Theory & Antenna

Course Code: EC401

Contact: 3:0:0

Total Contact Hours: 36

Credits: 3

Prerequisites:

The candidates should learn basic knowledge of vector calculus, electrostatic, magnetostatics.

Course Outcome:

Graduates of the ECE program will be able to:

CO1: Understand the knowledge of static fields and time-varying electromagnetic fields as governed by Maxwell's equations.

CO2: To understand in-depth study of transmission lines which play an important role in high-speed digital design and signal integrity of PCBs.

CO3: To analyze the fundamentals of antenna theory.

CO4: Understand the different types of antennas and their radiation mechanism.

Course Content:

Module I: Electrodynamics

[12L]

Electric & magnetic boundary conditions between media interfaces, time varying Maxwell's equation, magnetic vector potential, Helmholtz's equation, plane wave in lossy dielectric, free-space, loss-less dielectric, conductor: skin depth, surface resistance.; Poynting theorem, reflection of plane waves at normal and oblique incidence; diffraction and scattering phenomena.

Module II: Transmission Line

[12L]

Concept of lumped parameters, transmission line equation & their solution, propagation constant,

characteristic impedance, wavelength, velocity of propagation for distortion less line and loss-less line; reflection and transmission coefficients, standing wave, VSWR, input impedance; Smith chart; some impedance techniques - quarter wave matching, matching with lumped elements (L-networks), T-line in time domain, lattice diagram calculation, pulse propagation on T-line.

Module III: Antenna & wave propagation

[12L]

1. Antenna characteristics: radiation pattern, beamwidth, radiation efficiency, directivity, gain, efficiency, input impedance, polarization, effective area; Friis transmission equation.
2. Radiation characteristics of Hertzian dipole antenna.
3. Properties and typical application: -half-wavedipole, monopole, loop antenna, parabolic & corner reflector antenna, helical antenna, pyramidal horn antenna, micro-strippatch antenna, array: Yagi-Uda, log-periodic.

Textbooks:

1. Principles of Electromagnetics, 6th Edition, Matthew O H Sadiku, Oxford University Press.
2. Antenna Theory: Analysis & Design, Constantine A. Balanis; Wiley, 4th Edition.
3. Electromagnetics with applications, 5th ed, J.D. Kraus and D. Fleisch, McGraw Hill, 1999.

ReferenceBooks:

1. EngineeringElectromagnetics,HaytandBuck,7thedition,McGrawHill.
2. Fields&WaveinCommunicationElectronics,S.Ramo,J.R. Whinnery&T. VanDuzer,JohnWiley.
3. Electromagnetics,2edEdition–JAEdminister,Tata-McGraw-Hill.
4. EngineeringElectromagnetics,2edEdition- NathanIda,SpringerIndia.

CO-POMapping:

	PO1	PO2	PO3	PO4	PO5	PO6	PO7	PO8	PO9	PO10	PO11	PO12	PSO1	PSO2	PSO3
CO1	3	2	1	1			2			2	2	1	1	2	
CO2	3	3	2	1	2	2	1			1	2	2	2	2	
CO3	2	2	1	3		3			2			2	1	2	
CO4	2	2		1		2	2			2	2	1	2	2	
CO5	3	3	3		3	3	0		3			2	2	1	
AVG	2.6	2.4	1.8	1.5	2.5	2.5	1.25		2.5	1.7	2	1.6	1.6	1.8	

WeightageValues:3 =Strongly matched,2= Moderatelymatched, 1=Weakly matched,(-)=Notmatched.

Course Name: Analog Circuits

Course Code:EC402

Contact:3:0:0

Total Contact Hours: 36

Credits:3

Prerequisites: Basic knowledge about components (R, L, C). Network Theorems (Kirchhoff's law, Thevenin's theorem, Norton's theorem, Miller theorem etc.). Basic knowledge about the operation of semiconductor devices (Diode, Transistor, JFET, MOSFET, etc.), Basic idea of integrated circuit, Voltage current equations. Basic knowledge of Differentiation, Integration, Differential equation, matrix etc.

Course Outcome:

Graduates of the ECE program will be able to:

CO1: Students will be able to design, construct and analyse transistor amplifier circuit in audio frequency range with the help of h-parameter model.

CO2: Students will be able to understand concept of feedback in amplifier and classify amplifiers based on feedback topology.

CO3: Students will be able to design, construct and analyse signal generator circuit in both audio frequency and radio frequency range using transistor.

CO4: Student will be able to design, construct and analyse power amplifier circuit in audio frequency range.

CO5: Students will be able to design, construct and analyse linear and nonlinear electronic circuits using OPAMP (I.C-741).

Course Content:

Module I:

[11L]

RECTIFIER AND SINGLE STAGE TRANSISTOR AMPLIFIER: Rectifier and filter (Basic idea),

Regulated power supply using Zener diode and IC

Transistor CE, CB, CC configuration, transistor static characteristics in CE, CB mode, junction biasing condition for active, saturation and cut-off modes, current gain α , β . Biasing techniques, Q-point & its Stability, Thermal Runaway, self-bias CE configuration, Bias Compensation techniques, h-parameter model of transistors. Expression for voltage gain, current gain, input and output impedance, power gain, Emitter follower circuit.

MULTISTAGE AMPLIFIER: Different coupling techniques, RC coupled amplifier, functions of all components, derivation of voltage gain, current gain, input impedance and output impedance, High frequency model of transistors (hybrid- π model), frequency response characteristics, bandwidth

Module II:

[6L]

FEEDBACK AMPLIFIERS: Feedback concept, negative & positive feedback, Gain calculation for positive and negative feedback condition, Feedback topology.

OSCILLATORS: Barkhausen criterion, RC Oscillators - Phase shift and Wien bridge oscillators, LC Oscillator - Colpitts, Hartley's, and crystal oscillators.

Module III:

[7L]

POWER AMPLIFIERS: Class A, B Conversion efficiency, Tuned amplifier.

FET AMPLIFIERS: Operating principle of JFET. drain and transfer characteristics of JFET (n-channel and p-channel), E-MOSFET (n-channel and p-channel), D-MOSFET (n-channel and

p-channel), Equivalent circuit of JFET and MOSFET, Common-source, Common gate amplifiers.

Module IV:

[10L]

OPERATIONAL AMPLIFIER & IT'S APPLICATIONS: Ideal & Non-Ideal OPAMP, configuration of inverting and non-inverting amplifier using Op-amp, closed loop voltage gains of inverting and non-inverting amplifier, Internal block diagram of Op-amp, integrator & differentiator circuit, Log & Anti-log amplifiers, Comparator & Schmitt Trigger, Low pass, high pass and band pass active filters.

Module V:
[2L]

MULTIVIBRATORS: Astable and Monostable operation using I.C-555 timer.

Textbooks:

1. Sedra & Smith - Microelectronic Circuits - Oxford UP
2. Millman & Halkais - Integrated Electronics, McGraw Hill.
3. Boylestad & Nashelsky - Electronic Devices and Circuit Theory - Pearson/PHI
4. Rashid - Microelectronic Circuits - Analysis and Design - Thomson (Cengage Learning).
5. Franco - design with Operational Amplifiers & Analog Integrated Circuits, 3/e, McGraw Hill.
6. Gayakwad R.A - Op Amps and Linear IC's, PHI

Reference Books:

1. Razavi - Fundamentals of Microelectronics - Wiley
2. J.B. Gupta - Electronic Devices and Circuits - S.K. Kataria & Sons
3. Malvino - Electronic Principles, 6/e, McGraw Hill

CO- PO Mapping:

	PO1	PO2	PO3	PO4	PO5	PO6	PO7	PO8	PO9	PO10	PO11	PO12	PSO1	PSO2	PSO3
CO1	3	3	3	3	2		2					3	3	2	
CO2	3	3	3	3	2	2	2					3	3	2	
CO3	3	3	3	3	2		2					3	3	2	
CO4	3	3	3	3	2		2					3	3	2	
CO5	2	3	3	3	2		2					3	3	1	
AVG	2.8	3	3	3	2	2	2					3	3	1.8	

Weightage Values: 3 = Strongly matched, 2 = Moderately matched, 1 = Weakly matched, (-) = Not matched.

Course Name: Digital Electronics

Course Code: EC403

Contact: 3:0:0

Total Contact Hours: 36

Credits: 3

Prerequisites: A basic course in Electronics and Communication Engineering

Progresses from the fundamentals of electricity, direct current (DC) devices and circuits, series and parallel circuits to the study of active and passive components, Ohm's Law, Kirchhoff's Law i.e. KVL, KCL, Ampere's Law etc.

Course Outcome:

Graduates of the ECE program will be able to:

CO1: Acquired knowledge about solving problems related to number systems conversions and Boolean algebra and design logic circuits using logic gates to their simplest forms using DeMorgan's Theorems; Karnaugh Maps.

CO2: Design of combinational circuits and application

CO3: Design of various synchronous and asynchronous sequential circuits using State Diagrams & Tables.

CO4: Understand DAC & ADC technique and corresponding circuits

CO5: Analyze logic family interfaces, switching circuits to Plan and execute projects.

Course Content:

Module I:

[8L]

Binary, Octal and Hexadecimal number system representation and their conversions; BCD, ASCII, EBCDIC, Graycodes and their conversions. Signed binary number representation with 1's, 2's, 9's and 10's complement methods, Binary arithmetic. Boolean algebra; Various Logic gates- their truth tables and circuits; Implementation of various logic Gates using Universal Logic Gate, Representation in SOP and POS forms; Minimization of logic expressions by algebraic method, K-map method, Quine-McCluskey minimization technique (Tabular Method).

ModuleII:**[9L]**

Combinationalcircuits-

HalfAdder,FullAdder,Serial&ParallelAdder,CarryLookAheadAdder,BCDAdder,HalfSubtractor, Full Subtractor circuits, Adder-Subtractor Circuit. Encoder, priorityencoder, Decoder, Multiplexer, DeMultiplexer, Adder & Subtractor Design using decoder & multiplexer, Boolean Function representation by MUX,Comparator and Parity Generator-Checker.

ModuleIII:**[11L]**

Sequential Circuits-latch&FlipFlops-S-R,J-K,D andT,Conversionof FlipFlops,Varioustypesof ShiftRegisters-SISO,PISO,SIPO,PIPO,Bidirectional&UniversalShift.ModulusCountersSynchronous,Asynchronous,Irregular , Self-Correcting Ring & Johnson Counter.Application of Counter (Stepper motor control), Finite statemachine,statetransitiondiagramsandstatetransition tables.

ModuleIV:**[8L]**

Parameters of D/A & A/D Converters. Different types of A/D -Flash Type, Successive Approximation and DualSlopeandD/A-R-2RLadder&BinaryWeighted ResistorType. Logicfamilies-TTL,CMOS,NMOS,PMOS&their operation and specifications. TTL EquivalentCircuit.

Textbooks:

1. A.AnandKumar,FundamentalsofDigitalCircuits-PHI
2. MorriesMano-DigitalLogic Design-PHI
3. S.Salivahanan&S.Arivazhagan,DigitalCircuit&Design-BikasPublishing
4. A.K.Maini-DigitalElectronics-Wiley-India

Reference:

1. Floyed&Jain- DigitalFundamentals-Pearson.
2. R.P.Jain—ModernDigitalElectronics,2/e ,McGrawHill
3. H.Taub&D.Shilling,DigitalIntegratedElectronics-McGrawHill.
4. D.RayChaudhuri-DigitalCircuits-Vol-I&II,2/e-PlatinumPublishers
5. Kharate-DigitalElectronics-Oxford
6. Tocci,Widmer,Moss- DigitalSystems,9/e-Pearso

CO-POMapping:

	PO1	PO2	PO3	PO4	PO5	PO6	PO7	PO8	PO9	PO10	PO11	PO12	PSO1	PSO2	PSO3
CO1	3	3	1	3	1	1	1					2	2	1	
CO2	3	3	1	3	1	1	1					1	2	2	
CO3	3	3	1	3	1	1	1					2	3	3	
CO4	3	3	1	3	1	1	1					1	3	2	
CO5	3	3	1	3	1	1	1					2	3	2	
AVG	3	3	1	3	1	1	1					1.6	2.6	2	

Weightage Values: 3 = Strongly matched, 2 = Moderately matched, 1 = Weakly matched, (-) =Notmatched.

CourseName:Analog&DigitalCommunication

Course Code: EC 404

Contact: 3:0:0

Total Contact Hours: 36

Credit:3

Prerequisite: Trigonometric Fourier series, Exponential Fourier series, Fourier transform and its properties, Energy and power signal, Probability & Statistics.

CourseOutcome:

Graduates of the ECE program will be able to:

CO1: Explain the importance, Signal to Noise ratio, efficiency, and Bandwidth, of Amplitude modulation and demodulation schemes.

CO2: Analyse signal vector representation of various digitally modulated signals by creating signal constellation.

CO3: Demonstrate the concepts of sampling, Pulse Modulation techniques and their comparison.

CO4: Design Optimum (Matched) filter, demonstrate the effects of Inter Symbol Interference (ISI)

CO5: Illustrate various types of coherent and non-coherent digital modulation techniques, analyse immunity parameters and calculate their error probabilities

Course Content:

MODULE I: Introduction to Analog Communication [6]:

Elements of communication system - Transmitters, Transmission channels & receivers, Concept of modulation, its needs.

Review of signals and systems, Frequency domain representation of signals, Principles of Amplitude Modulation and Demodulation, Modulation index, Power content and bandwidth requirement Systems - DSB (Balanced Modulator for DSB-SC, Phase Shift method for SSB-SC), SSB and VSB modulations. (AM demodulator: Synchronous detection for DSB-SC, Super Hetero Dyne receiver, Image frequency), Angle Modulation (reactance modulator) and Demodulation Systems (PLL or frequency discriminator) - Representation of FM and PM signals, Spectral characteristics of

anglemodulated signals.

MODULE-II: Random Processes:

[6L]

Review of probability and random process. Gaussian and white noise characteristics, Rayleigh's energy theorem, Parseval's theorem, Fourier transform pair Power spectral density vs Autocorrelation likelihood functions, Noise in amplitude modulation systems, Pre-emphasis, and De-emphasis.

MODULE-III: Pulse modulation:

[6L]

Basic block diagram of Digital Communication system, advantages of digital communication system over analog communication system, Sampling theorem. Quantization, quantization error Pulse modulation techniques PAM, PWM, PPM. Pulse code modulation (PCM), Line coding, Regenerative repeater, differential pulse code modulation. Delta modulation, Noise analysis, PCM-TDM, Time Division multiplexing.

MODULE-IV: Signal Vector Representation:

[8L]

Analogy between signal and vector, distinguishability of signal, orthogonality and orthonormality, basis function, orthogonal signal space, message point, signal constellation, geometric interpretation of signals, Schwartz inequality, Gram-Schmidt orthogonalization procedure, response of the noisy signal at the receiver, maximum likelihood decision rule, decision boundary, optimum correlation receiver; probability of error, error function, complementary error function, Optimum detection of signals in noise, matched Filter, Intersymbol Interference and Nyquist criterion.

MODULE-V: DIGITAL MODULATION TECHNIQUES:

[10L]

Types of Digital Modulation, coherent and non-coherent ASK, FSK and PSK, Coherent Binary Phase Shift Keying (BPSK), geometrical representation of BPSK signal; error probability of BPSK, generation and detection of BPSK signal, power spectrum of BPSK. DPSK and DEPSK, Concept of M-ary Communication, M-ary phase shift keying, the average probability of symbol error for coherent M-ary PSK, power spectrum of MPSK, Quadrature Phase Shift Keying (QPSK), error probability of QPSK signal, generation and detection of QPSK signals, power spectrum of QPSK signals, Offset (OQPSK) vs. Non-offset (NOQPSK) Quadrature Phase shift keying, Coherent Frequency Shift Keying (FSK), Binary FSK, error probability of BFSK signals, generation and detection of Coherent Binary FSK signals, power spectra of BFSK signal, QAM, Minimum Shift Keying (MSK), signal constellation of MSK waveforms, error probability of MSK signal, Gaussian Minimum Shift Keying (GMSK), basic concept of OFDM.

TEXTBOOKS:

1. HaykinS., "CommunicationsSystems", JohnWileyandSons,2001.
2. PrinciplesofCommunicationSystems, H. TaubandD.Schilling, TMH PublishingCo.
3. WirelessCommunicationand Networks:3Gand Beyond,I. AshaMisra,TMHEducation.
4. CommunicationSystems, A. BruceCarlson, PaulB. CrillyTMHEducation.

REFERENCEBOOKS:

1. DigitalCommunicationsFundamentalsandApplications,B.SklarandP.K.Ray,Pearson.
2. ModernDigitalandAnalogCommunicationSystems,B.P.LathiandZ.Ding,OxfordUniversityPress.
3. DigitalCommunication,A.Bhattacharya,TMHPublishingCo.
4. DigitalCommunicationsbyDr.SanjaySharma S KKataria andSons

CO-PO Mapping:

	PO1	PO2	PO3	PO4	PO5	PO6	PO7	PO8	PO9	PO10	PO11	PO12	PSO1	PSO2	PSO3
CO1	3	3	3	-	1	1	-	-	-	3	3	3	2	2	
CO2	3	-	-	3	3	-	2	-	1	3	3	3	3	2	
CO3	3	3	3	3	2	2	-	2	-	3	3	3	2	2	
CO4	3	-	3	2	3	-	2	-	2	3	3	3	3	3	
CO5	3	2	-	3	3	2	-	-	-	3	3	3	2	2	
AVG	3	2.7	3	2.75	2.4	1.7	2	2	1.5	3	3	3	2.4	2.2	

Weightage Values: 3 =Strongly matched, 2= Moderatelymatched, 1=Weakly matched, (-)=Notmatched.

Course Name: Digital Signal processing

Course Code: EC405

Contacts: 3:0:0

Contact Hours: 36

Credits: 3

Course outcomes:

Graduates of the ECE program will be able to:

- CO1:** Define discrete-time systems in the Frequency domain using DFT
- CO2:** Describe the process of finding system response using various method.
- CO3:** Discriminate the computation technique and speed of operation in FFT with respect to DFT.
- CO4:** Design digital filters for various applications.
- CO5:** Apply digital signal processing for the analysis of real-life signals for image processing Applications using classifiers

Prerequisite:

Prerequisites for Digital Signal Processing are required a thorough understanding of various signals, systems, and the methods to process a digital signal and also the knowledge of arithmetic of complex numbers and a good grasp of elementary calculus. The questions reflect the kinds of calculations that routinely appear in Signals. The candidates are expected to have a basic understanding of discrete mathematical structures. The candidates required the concept of Z-transform, Relation between Fourier transform and Z transform, Properties of ROC and properties of Z transform, Initial value theorem and final value theorem, stability considerations for LTI systems using Z-transform, Inverse Z-transform by Residue method, power series & partial-fraction expansions.

Course Content

Module –I: Discrete Fourier Transform and Fast Fourier Transform:

[12L]

Definition of DFT and IDFT, Twiddle factors and their properties, multiplication of DFTs, circular convolution, computation of circular convolution by graphical, DFT/IDFT and matrix methods, filtering of long data sequences using Overlap-Save and Overlap-Add methods. Parseval's Identity, Difference between DFT and FFT. Radix-2 algorithm, Decimation-In-Time, Decimation-In-Frequency algorithms, signal flow graphs Butterflies, Bit reversal.

Module –II: Filter Design:

[17L]

Basic concepts of IIR and FIR filters: Moving average system, Autoregressive system, Pole-zero system, Non-recursive and recursive structures, Low pass FIR digital filters, High pass FIR digital filters, Band pass FIR digital filters, Notch FIR digital filters, difference equations, Realization of Filters using Direct form –I, II, transposed structure, Cascade & Parallel Form, Factors influencing choice of structure, Design of IIR Filter using impulse invariant and bilinear transforms, approximation & Design of analog Butterworth Filter, Design of Analog Low pass Chebyshev filters, Comparison between Butterworth Filter and

Chebyshev filters, Design of linear phase FIR filters, Concept of Symmetric & anti-Symmetric FIR Filter, Various kinds

of Window: Rectangular, Triangular, Raised Cosine, Hanning, Hamming, Blackman and Kaiser windows.

MODULE–III: Finite word Length Effects in Digital Filters:

[4L]

Input Quantization error, Product Quantization error, Coefficient, Quantization error, Zero-input Limit cycle Oscillations, Dead band, limit cycle Oscillations.

MODULE–IV: Application of DSP:

[3L]

Introduction to DSP Hardware TMS320C5416/6713 processor. Concept of Sub-band coding, Speech analysis.

Application of DWT for image analysis

Textbooks:

1. Digital Signal Processing – Principles, Algorithms and Applications, J.G. Proakis & D.G. Manolakis, Pearson Ed.
2. Digital Signal Processing, S. Salivahanan, A. Vallabraj & C. Gnanapriya, TMH Publishing Co.
3. Digital Signal Processing, P. Rameshbabu, Scitech Publications (India).
4. Digital Signal processing – A Computer Based Approach, S.K. Mitra, TMH Publishing Co.

Referencebooks:

1. Digital Signal Processing; Spectral Computation and Filter Design Chi-Tsong Chen, Oxford University Press
2. Texas Instruments DSP Processor user manuals and application notes

Mapping of POs with COs:

	PO1	PO2	PO3	PO4	PO5	PO6	PO7	PO8	PO9	PO10	PO11	PO12	PSO1	PSO2	PSO3
CO1	3	3	1	1			2	1		2	2	3	3	2	2
CO2	3	2	2	1	2	1	1	2		1	2	3	3	2	2
CO3	3	2	1	3		3			2			3	3	2	2
CO4	2	2		1		2	2	1		2	2	1	3	2	1
CO5	2	3	3		3	3	0	1	3			2	3	1	1
AVG	2.6	2.4	1.8	1.5	2.5	2.3	1.3	1.3	2.5	1.7	2	2.4	3	1.8	1.6

Weightage Values: 3 = Strongly matched, 2 = Moderately matched, 1 = Weakly matched, (-) = Not matched

CourseName:Gender,CultureandDevelopment

CourseCode:HSMC402

Contacts: 2:0:0

Total Contact Hours: 24

Credit:2

Prerequisite:None

CourseOutcomes:

GraduatesoftheECEprogramwillbeable to:

CO1: Provide an analysis of the location of women in the processes of economic development.to understand what economic development is, the scales or levels at which it occurs, andthecentrality ofgenderat every level.

CO2: Examine theoreticalandconceptualframeworksforthatanalysis.

CO3: Reflect upon linkages between the global economy and the gendered macro andmicroprocessofdevelopmentandtransitionsfrom‘government’to‘governance.’

CO4: Explaintheusefulnessof arights-basedapproachtogender justice.

CO5: Provide basis for research, practical action, and policy formulation and or evaluatingforevaluatingdirectionsandstrategiesforsocialchange fromagender perspective.

Course Content

Module1:

4L

IntroductiontoGender,DefinitionofGender,BasicGenderConceptsandTerminology,ExploringAttitudestowards Gender,SocialConstruction ofGender

Module2:

6L

GenderRolesandRelations,TypesofGenderRoles,GenderRolesandRelationshipsMatrix,Gender-basedDivisionandValuation ofLabour

Module3:

5L

GenderDevelopmentIssues,IdentifyingGenderIssues,GenderSensitiveLanguage,Gender,GovernanceandSustai nableDevelopment,GenderandHuman Rights,Genderand Mainstreaming.

Module4:**5L**

Gender-based Violence, The concept of violence, Types of Gender-based violence, The relationship between gender, development and violence, Gender-based violence from a human rights perspective.

Module5:**4L**

Gender and Culture Gender and Film, Gender and Electronic Media, Gender and Advertisement, Gender and Popular Literature.

Textbooks:

1. Beneria, Lourdes. (2004). Gender, Development, and Globalization: Economics as if All People Mattered. Routledge Press. (GDGE)
2. Molyneux and Razavi. (2002). Gender Justice, Development and Rights. Oxford University Press (GJDR or WGD)
3. Visvanathan, Duggan, Wiegersma and Nisonoff. (2011). The Women, Gender and Development Reader. 2nd Edition. Zed Press (WGD)

CO-PO Mapping:

COs\POs	PO1	PO2	PO3	PO4	PO5	PO6	PO7	PO8	PO9	PO10	PO11	PO12	PSO1	PSO2	PSO3
CO1						2	-	-	-	2	3	1			
CO2						2	-	2	2	-	3	2	1	1	
CO3						3	2	-	2	3	3	1			
CO4						-	-	2	-	3	3	2			
CO5						2	2	-	2	-	3	1			
AVG						2.25	2	2	2	2.7	3	1.4	1	1	

Weightage Values: 3 = Strongly matched, 2 = Moderately matched, 1 = Weakly matched, (-) = Not matched.

Course Name: EM theory and Antenna Lab

Course Code: EC491

Contact: 0:0:3

Credit: 1.5

Prerequisite:

The candidates should learn basic knowledge of vector calculus, electrostatic magnetostatics.

Course Outcome:

Upon the completion of the course the students will be able to

CO1: Understand the basics of transmission lines in which EM wave propagate.

CO2: Define and identify different types of transmission line, its characteristics in various load conditions.

CO3: To realize the fundamentals of antenna theory.

CO4: Understand the different types of antennas and the radiation mechanism.

List of Experiments:

1. Familiarization of basic elements of the Transmission Line.
2. Plotting of Standing Wave Pattern along a transmission line when the line is open-circuited, short-circuited at the load end.
3. Plotting of Standing Wave Pattern along a transmission line when the line is terminated by different load at the load end.
4. Unknown load Impedance of a terminated transmission line using shift in minimum technique.
5. Study of parameter transmission line using Smith chart.
6. Study of electromagnetic phenomena of transmission lines in simulation software's.
7. Familiarization with antenna parameters measurement set-up and different antenna.
8. Radiation Pattern of dipole antenna and Monopole with ground plane.
9. Radiation Pattern of a folded-dipole antenna.
10. Radiation pattern of a Log-Periodic Antenna.
11. Beamwidth, gain and radiation pattern of a 3-element, 5-element, and 7-element.

12. Yagi-Udaantenna –Comparative study.
13. Radiationpattern,Gain,Directivityof a PyramidalHornAntenna.

CO-PO-PSO Mapping:

	PO1	PO2	PO3	PO4	PO5	PO6	PO7	PO8	PO9	PO10	PO11	PO12	PSO1	PSO2	PSO3
CO1	3	3	3	3	2	-	-	-	3	2	-	3	3	2	-
CO2	3	3	3	3	2	-	-	-	3	2	-	3	3	2	-
CO3	3	3	3	3	2	-	-	-	3	2	-	3	3	2	-
CO4	3	3	3	3	2	2	-	-	3	2	-	3	3	2	-

WeightageValues:3 =Strongly matched,2 =Moderatelymatched,1 =Weakly matched,(-)=Notmatched.

CourseName:Analog Circuits Lab

Course Code: EC492

Contact:0:0:3

Credit:1.5

Prerequisites:A basic course in Electronics and Communication engineering Progresses from the fundamentals of electricity, active and passive components, basic electronics laws like Ohm's law, Ampere's law.

CourseOutcome:

Graduates of the ECE program will be able to:

CO1: Students will be able to design transistor based single stage R-C coupled voltage amplifier, differential amplifier, and different classes of power amplifier circuit with given specification.

CO2: Students will be able to design transistor-based RC oscillator (Wien bridge and RC phase shift oscillator) circuit.

CO3: Students will be able to construct a stable and mono-stable mode timer circuit using IC 555.

CO4: Students will be able to design Integrator, differentiator, and low pass & high pass active filter circuit using Op-Amp (I.C-741)

List of Experiments:

1. Design of voltage regulator using IC.
2. Study of input and output characteristics of CE mode BJT
3. Design of RC coupled amplifier in CE mode & study of its frequency response using BJT.
4. Design of RC Phase shift oscillator using BJT and measurement of its output frequency.
5. Design of Wien bridge oscillator using BJT and measurement of its output frequency.
6. Design of class A & class B push-pull power amplifiers and measurement of its power conversion efficiency.
7. Study of drain and transfer characteristics of single stage voltage amplifier JFET.
8. Design of Integrator using OPAMP (IC-741) and study of its frequency response.
9. Design of Differentiator using OPAMP (IC-741) and study of its frequency response.

10. Design of low pass and high pass active filter using OPAMP (IC-741) and study of its frequency response.
11. Design of Schmitt trigger circuit using OPAMP (IC-741) and study of its voltage transfer characteristic.
12. Design of astable and monostable multivibrator using timer (IC-555) and measurement of its duty cycle.
13. Innovative Experiments

Textbooks:

1. Sedra & Smith - Microelectronic Circuits - Oxford UP
2. Millman & Halkais - Integrated Electronics, McGraw Hill.
3. Boylestad & Nashelsky - Electronic Devices and Circuit Theory - Pearson/PHI
4. Rashid - Microelectronic Circuits - Analysis and Design - Thomson (Cengage Learning).
5. Franco - design with Operational Amplifiers & Analog Integrated Circuits, 3/e, McGraw Hill.
6. Gayakwad R.A - Op Amps and Linear IC's, PHI

Reference Books:

1. Razavi - Fundamentals of Microelectronics - Wiley
2. J.B. Gupta - Electronic Devices and Circuits - S.K. Kataria & Sons
3. Malvino - Electronic Principles, 6/e, McGraw Hill

CO- PO Mapping:

CO	PO1	PO2	PO3	PO4	PO5	PO6	PO7	PO8	PO9	PO10	PO11	PO12	PSO1	PSO2	PSO3
CO1	3	3	3	3	2	-	2	-	3	-	-	3	2	1	
CO2	3	3	3	3	2	2	2	-	3	-	-	3	2	2	
CO3	3	3	3	3	2	-	2	-	3	-	-	3	2	1	
CO4	3	3	3	3	2	-	2	-	3	-	-	3	1	2	
AVG	3	3	3	3	2	2	2		3			3	1.75	1.5	

Weightage Values: 3=Strongly matched, 2=Moderately matched, 1=Weakly matched, (-)=Not matched.

Course Name: Digital Electronics Lab

Course Code: EC493

Contact: 0:0:3

Credit: 1.5

Prerequisites: A basic course in Electronics and Communication engineering Progresses from the fundamentals of electricity, active and passive components, basic electronics laws like Ohm's law, Ampere's law.

Course Outcome:

Graduates of the ECE program will be able to:

CO1: Able to understand the fundamental concepts and techniques used in digital electronics.

CO2: Able to understand and examine the structure of various number system De- Morgan's law, Boolean algebra, and its application in digital design.

CO3: Able to understand, analyse the timing properties (input setup and hold times, minimum clock period, output propagation delays) and design various combinational and sequential circuits using various metrics: switching speed, throughput/latency, gate count and area, energy dissipation and power.

CO4: Able to understand different TTL logic.

CO5: Able to design digital circuits by their own.

List of Experiments:

1. Realization of basic gates using Universal logic gates.
2. Design the circuit of Grey to Binary and vice versa.
3. Design a circuit for BCD to 7-segment display.
4. Four-bit parity generator and Two-bit comparator circuits.
5. Construction of simple Encoder & Decoder circuits using logic gates.
6. Construction of simple Multiplexer & De Multiplexer circuits using logic gates.
7. Design of Half Adder & Full Adder Circuit using Logic Gates.

8. Design Half Subtractor & Full Subtractor Circuit using Logic Gates.
9. Realization of RS, D, JK and T flip-flops using logic gates.
10. Realization of Register using flip-flops and logic gates.
11. Realization of Up/Down counters
12. Realization of logic gates using TTL.
13. One innovative design of Digital Circuits.

Textbooks:

1. A. Anand Kumar, Fundamentals of Digital Circuits - PHI
2. Morris Mano - Digital Logic Design - PHI
3. S. Salivahanan & S. Arivazhagan, Digital Circuit & Design - Bikas Publishing
4. A. K. Maini - Digital Electronics - Wiley - India

Reference:

1. Floyed & Jain - Digital Fundamentals - Pearson.
2. R. P. Jain — Modern Digital Electronics, 2/e, McGraw Hill
3. H. Taub & D. Shilling, Digital Integrated Electronics - McGraw Hill.
4. D. Ray Chaudhuri - Digital Circuits - Vol-I & II, 2/e - Platinum Publishers
5. Kharate - Digital Electronics - Oxford
6. Tocci, Widmer, Moss - Digital Systems, 9/e - Pearson

CO-PO Mapping:

	PO1	PO2	PO3	PO4	PO5	PO6	PO7	PO8	PO9	PO10	PO11	PO12	PSO1	PSO2	PSO3
CO1	3	3	3	1	3	1	1	1			1	3	3	2	
CO2	3	3	3	1	3	1	1		1	1	1	3	3	2	
CO3	3	3	3	3	3	2	2	1		1	2	3	3	2	
CO4	3	3	3	3	3	2	2	1		2	1	3	3	2	
CO5	3	3	3	3	3	1	2	1	2	2	2	3	3	1	
AVG	3	3	3	2.2	3	1.4	1.6	1	1.5	1.5	1.4	3	3	1.8	

Weightage Values: 3 = Strongly matched, 2 = Moderately matched, 1 = Weakly matched, (-) = Not matched.

Course Name: Analog & Digital Communication Systems Lab

Course Code: EC494

Contact: 0:0:3

Credit: 1.5

Prerequisites: Knowledge of signals and systems

Course Outcomes:

Upon the completion of the course the students will be able to

CO1: Understand the concept of analog and digital communication techniques and their applications.

CO2: Demonstrate to the practical methods of the use of generating communication signals.

CO3: Evaluate practical methods of the use of demodulation of communication signals.

CO4: Distinguish the significance of signal constellation and ~~peetral~~spectral width.

CO5: Develop ~~in-sight~~insight into the relations between the input and output signals in various stages of a

transmitter and a receiver.

List of Experiments:

1. Measurement of output power with varying modulation index in an AM signal (for both DSB- & SSB).
2. Measurement of the demodulated output with varying modulation index of an AM signal (for both DSB-SC & SSB).
3. Measurement of power of different frequency components of a frequency modulated signal & the measurement of the bandwidth.
4. Design a PLL using VCO & to measure the lock frequency.
5. Study of pulse amplitude modulation (PAM) and demodulation.
6. Study of PCM and demodulation.
7. Study of delta modulator and demodulator
8. Study of ASK modulator and demodulator
9. Study of BPSK modulator and demodulator
10. Study of BFSK modulator and demodulator.
11. Study of QPSK modulator and demodulator.
12. Innovative project: Breadboard realization of digital communication circuit for voice communication

Textbooks:

1. Haykin S., "Communications Systems", John Wiley and Sons, 2001.
2. Principles of Communication Systems, H. Taub and D. Schilling, TMH Publishing Co.
3. Wireless Communication and Networks: 3G and Beyond, I. Asha Misra, TMH Education.
4. Communication Systems, A. Bruce Carlson, Paul B. Crilly TMH Education.

Referencebooks:

1. DigitalCommunicationsFundamentalsandApplications,B.SklarandP.K.Ray,Pearson.
2. ModernDigitalandAnalogCommunicationSystems,B.P.LathiandZ.Ding,OxfordUniversityPress.
3. DigitalCommunication,A.Bhattacharya,TMHPublishingCo.
4. DigitalCommunicationsbyDr.SanjaySharma S K Kataria andSons
5. DigitalCommunications,J.G.Proakis,TMHPublishingCo.
6. DigitalCommunicationsFundamentalsandApplications,B.SklarandP.K.Ray,Pearson.
7. ModernDigitalandAnalogCommunicationSystems,B.P.LathiandZ.Ding,OxfordUniversityPress.
8. DigitalCommunication,A.Bhattacharya,TMHPublishingCo.
9. DigitalCommunicationsbyDr.SanjaySharma S K Kataria andSons
10. DigitalCommunications,J.G.Proakis,TMHPublishingCo.

CO-PO-PSO Mapping:

	PO1	PO2	PO3	PO4	PO5	PO6	PO7	PO8	PO9	PO10	PO11	PO12	PSO1	PSO2	PSO3
CO1	3	3	3	-	-	-	-	-	3	2	-	3	2	2	-
CO2	2	-	-	3	-	-	-	-	3	2	-	3	3	2	-
CO3	2	3	3	3	-	-	-	-	3	2	-	3	2	2	-
CO4	3	-	3	2	-	-	-	-	3	2	-	3	3	2	-
CO5	3	2	-	3		-	-	-	3	2		3	2	1	-

WeightageValues:3 =Strongly matched, 2 = Moderately matched, 1 =Weakly matched,(-)= Notmatched.

Course Name: Digital Signal Processing Lab

Course Code: EC495

Contacts: 0:0:3

Credits: 1.5

Prerequisite: Nil

Course Outcomes:

Upon the completion of the course the students will be able to

CO1: Compute the system output using convolution method with MATLAB Software package.

CO2: Verify the system characteristics.

CO3: Calculate DFT, FFT, IDFT using MATLAB.

CO4: Analyse Magnitude and phase characteristics (Frequency response Characteristics of digital IIR Butterworth).

CO5: Develop and Implement DSP algorithms in software using a computer language such as C with TMS320C6713 floating point Processor.

List of Experiments:

1. Convolution of two sequences using graphical methods and using commands- verification of the properties of convolution.
2. Systems (Causal and Non-causal, Time-Invariant and Time-variant etc.) verification using MATLAB.
3. Z-transform of various sequences – verification of the properties of Z-transform.
4. DFT using twiddle factors.
5. DFTs /IDFTs using matrix multiplication and also using commands.
6. Circular convolution of two sequences using graphical methods and using commands, differentiation between linear and circular convolutions.
7. Verification of the differential algorithms associated with filtering of long data sequences and overlap – add and Overlap-save methods.

8. Butterworth filter design with different set of parameters.
9. FIR filter design using rectangular, Hamming and Blackman windows.
10. Frequency responses of anti-imaging and anti-aliasing filters.
11. Develop and Implement DSP algorithms in software using a computer language such as C with TMS320C6713 floating point Processor, TMS5416 kit and ASM along with C.

Textbooks:

1. Digital Signal Processing – Principles, Algorithms and Applications, J.G. Proakis & D.G. Manolakis, Pearson Ed.
2. Digital Signal Processing, S. Salivahanan, A. Vallabraj & C. Gnanapriya, TMH Publishing Co.
3. Digital Signal Processing, P. Rameshbabu, Scitech Publications (India).
4. Digital Signal processing – A Computer Based Approach, S.K. Mitra, TMH Publishing Co.

Referencebooks:

1. Digital Signal Processing; Spectral Computation and Filter Design Chi-Tsong Chen, Oxford University Press
2. Texas Instruments DSPP Processor user manuals and application notes

CO-PO-PSO Mapping:

	PO 1	PO 2	PO 3	PO 4	PO 5	PO 6	PO 7	PO 8	PO 9	PO 10	PO 11	PO 12	PSO1	PSO2	PSO3
CO1	2	3	2	1	1	-	-	-	3	2	-	-	3	3	-
CO2	2	2	3	1	1	-	-	-	3	2	-	-	3	3	-
CO3	2	1	2	2	3	-	-	-	3	2	-	2	3	3	-
CO4	3	1	3	2	2	-	-	-	3	2	-	2	3	3	-
CO5	3	1	3	3	2	-	-	-	3	2	-	2	3	2	-

Weightage Values: 3 = Strongly matched, 2 = Moderately matched, 1 = Weakly matched, (-) = Not matched

Stream: ECE

Subject Name: Theme based Project IV

Subject Code: PR491

Contact hour: 1P

Total contact hour- 10

Credits: 0.5

Prerequisite: Course completed up to 3rd semester in UG ECE

Course Objective:

Prepare students with foundation knowledge in a project domain through surveying, designing, implementing, observing and reporting.

Methodology:

1. Thinking: Discussion on innovative idea.
2. Exploring: Survey of recent research.
3. Implementing: Project guidance to basic prototype implementation.
4. Documenting: Guidance on reporting and conference paper writing.
5. Each Theme based Project IV group should submit the following under their semester project report submission with topics not limited to,

Title, certificates, declaration by student, acknowledgement, Table of Contents, abstract, keywords, Introduction, Literature Survey, System Analysis (if applicable), System Design (if applicable), Coding, Testing (if applicable), Conclusion, Future Scope of work), reference

Course outcome:

Sem. No.	Course Title (Code)	CO Codes	Course Outcomes
			On completion of the course students will be able to
4 th	Theme based Project IV(PR491)	CO.PR491.1	Apply the knowledge acquired through survey of recent research to set the project goal.
		CO.PR491.2	Distinguish the way of implementation of prototype
		CO.PR491.3	Identify the fault issue through various case study
		CO.PR491.4	Implement the prototype using modern tools

CO-PO-PSO MAPPING:

COs\POs	PO1	PO2	PO3	PO4	PO5	PO6	PO7	PO8	PO9	PO10	PO11	PO12	PSO1	PSO2	PSO3
CO1	3	3	3	2	1	1	3		1	1		3	2	3	
CO2	3	3	3	3	3			3	3		2	3	3	3	2
CO3	2		3	3	2	2	3	3	2	2		3	3	2	1
CO4	1	3	3	2	3		3	2	3		2	3	3	3	3
AVG	2.25	3	3	2.5	2.25	1.5	3	2.67	2.25	1.5	2	3	2.75	2.75	2

Stream: ECE**Subject Name: Skill Development IV: Soft Skill & Aptitude-I****Subject Code: PR492****Contact hour:1P****Total contact hour- 10****Credits: 0.5****Prerequisite: Course completed up to 4th semester in UG ECE****Objective:**

Business Communication: To improve Communications skills, current English usage, debates, language games, situational dialogues, precis writing, essay writing, presentations.

Presentation Skills: To prepare for effective presentations, presentation for small groups and large groups, marketing and business presentations.

Business Correspondence: To explore the hidden potential of clear writing by identifying misused words, applications and requests, positive and negative responses to requests, routine messages, memos, report writing, organizing meetings, preparation of agenda and minutes, business etiquette, telephone etiquette, e-mail etiquette.

Benefits from the Training: To unveil the ability to communicate clearly and concisely as an advantage to a promising manager. The students will soon realize that fluency and command over speaking and writing gives them an edge while interacting with people at all levels.

Behavioral Skills: to identify an array of skills related to personal growth for efficient functioning constitutes the training. Students are made to realize their strengths and weaknesses so that they are able to grasp the true essence of development. They are made to take part in role plays, games, and puzzles that demonstrate the attributes needed for assertiveness, interpersonal relationships, negotiations, time and goal management, leadership skills, and conflict management.

Course outcome:

Sem. No.	Course Title (Code)	CO Codes	Course Outcomes
			On completion of the course students will be able to
4 th	Skill Development IV: Soft Skill & Aptitude-I (PR492)	CO1	Activate teamwork through learning to connect and work with others to achieve goal for a set task
		CO2	Build responsibility for one's self, learning self-reliance and independence.
		CO3	Communicate and demonstrate with clear briefing and listening skills, not being afraid to ask for help and support when necessary
		CO4	Construct emotional maturity and emotional health by learning to handle emotions including tolerance and behavioural responses, building positive friendships and bonding with peers and classmates, learning to show understanding and to demonstrate respect for the opinions, personal space and beliefs of others
		CO5	Explore Leadership quality by assessing the requirements of a task, identifying the strengths within the team, utilising the diverse skills of the group to achieve the set objective, awareness of risk/safety
		CO6	Grow confidence and enthusiasm for learning by developing self-motivation, raised aspirations and belief in one's own abilities, defining and committing to achieving one's goals

CO-PO-PSO MAPPING:

COs\POs	PO1	PO2	PO3	PO4	PO5	PO6	PO7	PO8	PO9	PO10	PO11	PO12	PSO1	PSO2	PSO3
CO1	3	3	3	2	1	1	3		1	1		3	2	3	
CO2	3	3	3	3	3			3	3		2	3	3	3	2
CO3	3		2	3	3	2		3	3	2		3	3	3	2
CO4	2		3	3	2	2	3	3	2	2		3	3	2	1
CO5	1	3	3	2	3		3	2	3		2	3	3	3	3
CO6		2	3	3	3	2	3	3	3			3	3		2
AVG	2.4	2.75	2.83	2.7	2.5	1.75	3	2.8	2.5	1.67	2	3	2.83	2.8	2

R21(B.TechECE)

Curriculum for B.Tech

UnderAutonomy

Electronics&CommunicationEngineering

(EffectiveFrom2021-22admissionBatch)

L–Lecture;T-Tutorial;P-Practical[1L=1Cr,1T=1Cr,1P=0.5Cr]

3rd Year 1st Semester: 5th Semester

Sl. No.	Category	CourseCode	CourseTitle	Hoursperweek				Credits/Unit
				L	T	P	Total	
A.THEORY								
1	HSMC	HSMC505	PrinciplesofManagement	2	0	0	2	2
2	PC	EC501	Microprocessor&MicroController	3	0	0	3	3
3	PC	EC502	RF&MicrowaveEngineering	3	0	0	3	3
4	PC	EC503	ComputerNetwork	3	0	0	3	3
5	PE	EC504	ProfessionalElective-I A:MobileCommunication&NetworkB:Fibre OpticCommunication C: Electronics Measurement & InstrumentationD:SatelliteCommunication	3	0	0	3	3
6	PE	EC505	ProfessionalElective-IIA:ComputerArchitecture B:DigitalImage&VideoProcessingC:EmbeddedSy stem D:Advanced PythonProgramming	3	0	0	3	3
B.PRACTICAL								
7	PC	EC591	Microprocessor&MicroControllerLab	0	0	3	3	1.5
8	PC	EC592	RF&MicrowaveEngineeringLab	0	0	3	3	1.5

9	PE	EC594	Professional Elective-I Lab A: Mobile Communication & Network Lab B: Fiber Optic Communication Lab C: Electronics Measurement & Instrumentation Lab D: Satellite Communication Lab	0	0	3	3	1.5
10	PE	EC595	Professional Elective-III Lab A: Computer Architecture Lab B: Digital Image & Video Processing Lab C: Embedded System Lab D: Advanced Python Programming Lab	0	0	3	3	1.5
11	PROJECT	PR591	Minor Project I	0	0	3	2	1
12	PROJECT	PR592	Skill Development V: Soft Skill & Aptitude-II	0	0	1	1	0.5
C. MANDATORY ACTIVITIES/COURSES								
13	MC	MC 501	Constitution of India	2	0	0	2	0
TOTAL CREDIT WITHOUT MOOC COURSES								24.5
D. MOOC COURSES** [For Honors/Minor]								
14	MOOC COURSES	HM501	MOOC COURSE-IV	3	1	0	4	4
TOTAL CREDIT WITH MOOC COURSES								28.5

****MOOC COURSES for HONOURS/MINOR Degree are Programs specific and to be taken from BASKET**

Course Name: Principles of Management

CourseCode: HSMC505

Contact:2:0:0

Total contact hour-24

Credits:2

Prerequisites:NIL

Courseoutcome:

On completion of the course students will be able to:

CO1: To recall and identify the relevance of management concepts.

CO2: To apply management techniques for meeting current and future management challenges faced by the organization

CO3: To compare the management theories and models critically to solve real life problems in an organization.

CO4: To apply principles of management in order to execute the role as a manager in an organization.

CourseContent:

Module-1:

Management Concepts: Definition, roles, functions and importance of Management, Evolution of Management thought - contribution made by Taylor, Fayol, Gilbreth, Elton Mayo, McGregor, Maslow (4L)

Module-2:

Planning and Control: Planning: Nature and importance of planning, -types of planning, Level of planning

-The Planning Process.-

MBO, SWOT Analysis, McKinsey's 7S Approach. Organizing for decision making: Nature of organizing, span of control, Organizational structure line and staff authority. Basic control process - control as a feedback system -

FeedForwardControl–Requirementsforeffectivecontrol–control (4L)

Module-3:

Groupdynamics:Typesofgroups,characteristics,objectivesofGroupDynamics.

Leadership:Definition,styles&functionsofleadership,qualitiesforgoodleadership,Theoriesofleadership (4L)

Module– 4:

Work Study and work measurement: Definition of work study, Method Study Steps, Tools and Techniques used intheMethodStudyandWorkMeasurementTimeStudy:Aim&Objectives,,Useofstopwatch procedure inmakingTimeStudy.Performancerating,allowancesanditstypes.CalculationofStandardTime.Worksampling

(4L)

Module-5:

MarketingManagement:FunctionsofMarketing,ProductPlanninganddevelopment,PromotionalStrategy(2L)

Module-6:

Quality management: Quality definition, Statistical quality control, acceptance sampling, Control Charts – Mean chart, range chart, c-chart, p-chart, np chart, Zero Defects, Quality circles, Kaizen & Six Sigma, ISO

-9000 Implementation steps, Total quality management

(6L)

Text Books:

Essentials of Management, by Harold Koontz & Heinz Weihrich Tata McGraw

Production and Operations Management - K. Aswathapa, K. Shridhara Bhat, Himalayan Publishing House

References: Organizational Behavior, by Stephen Robbins Pearson Education, New Delhi Newera

Management, Daft, 11th Edition, Cengage Learning

Principles of Marketing, Kotlar Philip and Armstrong Gary, Pearson publication **CO-CO-POMapping:**

COs	PO1	PO2	PO3	PO4	PO5	PO6	PO7	PO8	PO9	PO10	PO11	PO12	PSO1	PSO2	PSO3
CO1	-	-	-	-	-	-	-	-	3	-	3	-	2	2	-
CO2	-	-	-	-	-	2	-	3	3	-	3	3	2	2	-
CO3	-	-	-	-	-	-	-	-	2	-	3	3	2	2	-
CO4	-	-	-	-	-	2	-	-	3	-	3	-	1	2	-
AVG						2		3	2.8		3	3	1.8	2	

Weightage Values: 3 = Strongly matched, 2 = Moderately matched, 1 = Weakly matched, (-) = Not matched.

CourseName:MicroprocessorandMicrocontroller

CourseCode:EC 501

Contacts:3:0:0

Total Contact Hours: 36

Credit:3

Prerequisite: KnowledgeinDigitalElectronics.

CourseOutcomes:

GraduatesoftheECEprogramwillbeableto:

CO1:

Toexplainthearchitectureinstructions,timingdiagrams,addressingmodes,memoryinterfacing,interrupts,datacommunicationof8085,8086microprocessors and 8051microcontrollers.

CO2:

Able to interpret the 8086 microprocessor-Architecture, Pin details, memory segmentation, addressing modes,basicinstructions,interrupts.

CO3:

Recognize8051microcontrollerhardware,input/outputpins,ports,externalmemory,countersandtimers ,instructionset, addressing modes,serialdatai/o,interrupts.

CO4:

Applyinstructionsforassembly languageprogramsof8085, 8086and8051.

CO5:

Designperipheralinterfacing modelusing IC8255, 8253, 8251 with IC8085, 8086 and8051.

CourseContent:

Module1: 8085Microprocessor:

[6L]

IntroductiontoMicrocomputerbasedsystem,Evolutionof Microprocessor andmicrocontrollers and their advantages and disadvantages, Architecture of 8085Microprocessor,Address/DataBusMemoryinterfacing,IOinterfacing,ADC/DAC interfacing, Stack and Subroutine, Delay Calculation, Interrupts of8085processor,classification ofinterrupts.

Module 2: Assembly language programming with 8085:

[4L]

Addition,

Subtraction,

Multiplication,Block Transfer,ascendingorder,descendingorder,Findinglargest&smallest number,Look-uptableetc.Programmingusinginterrupts(programmingusingINTRisnotrequired). Instructionset,Addressing mode, TimingDiagram.

Module3: 8086Microprocessor: **[6L]**

8086 Architecture, Pin details, memory segmentation, addressing modes, Familiarization of basic Instructions, Interrupts&DirectMemoryAccess,Memoryinterfacing,ADC/DACinterfacing,PipelineArchitecture,MinimumandMaximummodeofaddressing, Queoperation.

Module4:Assemblylanguageprogrammingwith8086: **[3L]**

Addition, Subtraction, Multiplication, Block, Transfer, ascending order, descendingorder, Finding largest &smallestnumberetc.

Module5:8051Microcontroller: **[6L]**

Differencebetweenprocessorandcontroller,Featuresof8051microcontroller,8051architecture& Pin diagram, Memory organization, Direct and indirect Access of memory, SFR, PCON, SCON, TCON,TMOD, IE, IP, SBUFF serial data i/o, interrupts, Memory interfacing, ADC / DAC interfacing

Module 6: Assembly language Programming using 8051:**[5L]**

Moving data: External data moves, code memory read only datamoves, PUSH and POP opcodes, data exchanges; Logical operations: Byte-level, bit-level, rotate and swap operations;

Arithmetic operations: Flags, incrementing and decrementing, addition, subtraction, multiplication and

division, decimal arithmetic; Jump and call instructions: Jump and call program range, jumps, calls and subroutines, interrupts and returns, Instruction & addressing.

Module 7: Support IC chips:

[6L]

8255, 8253 and 8251: Block Diagram, Pin Details, Modes of operation, control word(s) format. Interfacing of support IC chips with 8085, 8086 and 8051.

Textbooks:

1. Microprocessor architecture, programming and application with 8085 – R. Gaonkar, Penram International
2. The 8051 microcontroller- K. Ayala, Thomson
3. Microprocessors & interfacing – D. V. Hall, Tata McGraw-hill
4. Ray & Bhurchandi, Advanced Microprocessors & Peripherals, TMH
5. The 8051 microcontroller and Embedded systems - Mazidi, Mazidi and McKinley, Pearson
6. An Introduction to Microprocessor and Applications – Krishna Kant, Macmillan

Reference Books:

1. Microprocessors and microcontrollers - N. Senthil Kumar, M. Saravanan and Jeevananthan, Oxford university press
2. 8086 Microprocessor – K. Ayala, Cengage learning
3. The 8051 microcontrollers – Uma Rao and Andhe Pallavi, Pearson

CO-PO Mapping:

	PO1	PO2	PO3	PO4	PO5	PO6	PO7	PO8	PO9	PO10	PO11	PO12	PSO1	PSO2	PSO3
CO1	3	3	3	3	3							3	3	3	2
CO2	3	2	3										3		3
CO3	2	3		3									3	1	2
CO4	3	1	3	2									2		1
CO5	1	3		3									1		3
AVG	2.4	2.4	3	2.75	3							3	2.4	2	2.2

Weightage Values: 3=Strongly matched, 2=Moderately matched, 1=Weakly matched, (-)=Not matched.

Course Name: RF & Microwave Engineering

Course Code: EC502

Contacts: 3:0:0

Total Contact Hours: 36

Credit: 3

Prerequisite: EM Theory & Antenna, Field theory, Analog Electronics

Course Outcomes:

Graduates of the ECE program will be able to:

CO1: Understand the Microwave Frequency range and their application.

CO2: Develop fundamental understanding of the Two-port RF network and matching techniques.

CO3: Learn the Scattering matrix for microwave passive components

CO4: Understand the Microwave tubes and devices along with their fundamental principle of Operation.

CO5: Learn the microwave measurement techniques.

Course Content:

Module 1: Introduction

[2L]

Introduction RF & Microwave Spectrum, Applications of Microwaves: Civil and Military, Medical, EMI/EMC, Safety considerations

Module 2: Microwave Waveguides

[10L]

Mathematical Model of Microwave Transmission in Parallel Plate Waveguide. Concept of Mode, Features of TEM, TE and TM Modes. Rectangular waveguide - TE₁₀ mode analysis, cut-off frequency, propagation constant, intrinsic wave impedance, phase and group velocity, power transmission, attenuation, waveguide

excitation, wall current. Concept of propagation constant, intrinsic wave impedance, phase and group velocity, power transmission, attenuation. Circular waveguide, Transmission line - Coaxial line, Planar Transmission line- Micro-strip lines, Coplanar waveguide, Slot line-design consideration, field patterns, propagation characteristics, Comparison for different characteristics of the above-mentioned lines.

Module 3: Microwave Network Analysis of Passive Components

[10L]

Realization of reactive elements as Waveguide and Planar Circuit components. Equivalent voltages and currents, Network parameters for microwave circuits, Scattering Parameters, Waveguide Passive Components and their S-matrix Representation N-port networks- Properties of S matrix, Transmission matrix & their relationships; Microwave passive components and their S matrix representation: Attenuators, Phase shifter, Directional coupler, Bethe-hole coupler, Magic tee, hybrid ring, Circulators, Isolators; Microwave filter

Module 4: Microwave Active Devices

[10L]

Microwave active components: Diodes, Transistors, Amplifiers, Oscillators, Mixers. Microwave Semiconductor Devices: Gunn Diodes, Transit Time diodes, Schottky Barrier diodes, PIN diodes. Microwave Tubes: Klystron, Reflex Klystron, Magnetron, TWT. Brief introduction to NBA, LNA

Module 5: Microwave Measurement

[4L]

Typical Microwave Test Bench & measurement VSWR meter, Tunable detector, Slotted line and Probe detector, Frequency meter, Network analyzer, Measurement of VSWR – low, medium and high, Measurement of power: low, medium and high, Frequency measurement.

Textbooks:

1. Samuel Y Liao, "Microwave Devices & Circuits", Prentice Hall of India, 2006.
2. Susrut Das, "Microwave Engineering", Oxford University Press, 2014.
3. Annapurna Das and Sisir Kumar Das, "Microwave Engineering", Tata Mc Graw Hill Inc., 3rd Edn. 2015.

Reference Books:

1. D.M.Pozar,“MicrowaveEngineering.”,JohnWiley&sons,Inc.,2006.
2. R.E.Collins,MicrowaveCircuits,McGrawHill
3. M.L.Sosodia,G.S.Raghuvanshi,“MicrowaveCircuitsandPassive Devices”,2010

CO-PO-PSO MAPPING:

	PO1	PO2	PO3	PO4	PO5	PO6	PO7	PO8	PO9	PO10	PO11	PO12	PSO1	PSO2	PSO3
CO1	3	2	1	1	-	-	2	-	-	2	2	1	1	2	-
CO2	3	3	2	1	2	2	1	-	-	1	2	2	2	2	-
CO3	2	2	1	3	-	3	-	-	2	-	-	2	1	2	-
CO4	2	2	-	1	-	2	2			2	2	1	2	2	-
CO5	3	3	3		3	3	0	-	3	-	-	2	2	1	-
AVG	2.6	2.4	1.8	1.5	2.5	2.5	1.25	-	2.5	1.7	2	1.6	1.6	1.8	-

Weightage Values:3=Stronglymatched,2=Moderatelymatched,1=Weaklymatched,(-)=Notmatched.

Course Name: Computer Network

Course Code: EC 503

Contacts: 3:0:0

Total Contact Hours: 36

Credit: 3

Prerequisite: Digital Communication

Course Outcomes:

CO1: Analyze various protocols in Data Communication

CO2: Analyze error control and flow control in Data Communication

CO3: Design Networking structure in Data communication

CO4: Analyze various encryption techniques, identify some of the factors driving the need for network Security.

Course Content:

Module 1:

Overview of Data Communication:

[3L]

Introduction; physical structure (type of connection, topology), categories of network (LAN, MAN, WAN); Internet: brief history, Protocols and standards; Reference models: OSI reference model, TCP/IP reference model, their comparative study.

Module 2:

Data Link Layers:

[7L]

Physical Level: Transmission media (guided & unguided); Circuit switching time division & space division switch, TDM bus

Data link Layer: Types of errors, framing(character and bit stuffing), error detection & correction methods; Flow control; Protocols: Stop & wait ARQ, Go-Back-N ARQ, Selective repeat ARQ, HDLC Medium Access sublayer: Point-to-Point Protocol, Token Ring; Multiple access protocols: Pure ALOHA, Slotted ALOHA, CSMA, CSMA/CD, CSMA/CA Traditional Ethernet, fast Ethernet (in brief)

Module 3:

Network Layers:

[10L]

Network layer: Internet networking & devices: Hubs, Bridges (Basic Idea), Switches, Router, Gateway; Addressing: IP addressing, subnetting; Routing: techniques, static vs. dynamic routing, Source and Hop-by-Hop routing (Dijkstra), Unicast Routing Protocols: RIP, OSPF, Other Protocols: ARP, IP, ICMP, IPV6

Transport layer: Process to Process delivery; UDP; TCP; Congestion Control: Open Loop, Closed Loop choke packets (Concept); Leaky bucket algorithm, Token bucket algorithm, WLAN (Basic Idea)

Module 4:

Application Layers:

[4L]

Application Layer: Introduction to DNS, SMTP, FTP, HTTP & WWW, Bluetooth (Basic Idea)

Module 5:

Security in Networking:

[12L]

Need for Security, Security Attack, Security Services, Information Security, Methods of Protection.

Symmetric Key Encryption: Data Encryption Standard (DES) Algorithm, Double and Triple DES, Security of the DES, Advanced Encryption Standard (AES) Algorithm, DES and AES Comparison. Public Key Encryption: Characteristics of Public Key System, RSA Technique, Cryptographic Hash Functions, Digital Signature Threats to E-Mail, Requirements and Solutions, Encryption for Secure E-Mail, Secure E-Mail System.

Firewalls – Types, Comparison of Firewall Types, Firewall Configurations.

TextBooks:

1. B.A.Forouzan –“Data CommunicationsandNetworking(3rdEd.)“–TMH
2. A.S.Tanenbaum–“ComputerNetworks(4thEd.)”–PearsonEducation/PHI
3. W.Stallings–“Data andComputerCommunications(5thEd.)”–PHI/PearsonEducation
4. Zheng&Akhtar, NetworkforComputerScientists&Engineers,OUP
5. Black,Data &ComputerCommunication,PHI
6. Shay,UnderstandingData Communication&Network,Vikas

ReferenceBooks:

1. KuroseandRose–“ComputerNetworking-Atopdownapproachfeaturingtheinternet”–PearsonEducation
2. Leon,Garica,Widjaja–“CommunicationNetworks”–TMH
3. Walrand–“CommunicationNetworks”–TMH.
4. WarwickFord,MichaelS.Baum,"SecureElectronicCommerce:BuildingtheInfrastructureforDigital

CO-PO Mapping:

COs	PO1	PO2	PO3	PO4	PO5	PO6	PO7	PO8	PO9	PO10	PO11	PO12	PSO1	PSO2	PSO3
CO1	3	2	1	1	-	-	1	-	3	3	1	1	2	2	2
CO2	2	2	3	3	2	2	-	-	3	3	3	3	2	2	2
CO3	2	2	2	2	2	1	-	-	3	3	1	3	3	1	2
CO4	3	2	2	2	2	3	-	-	3	3	2	3	1	2	1
AVG	2.5	2	2	2	2	2	1		3	3	1.75	2.5	2	1.75	1.75

Weightage Values: 3 = Strongly matched, 2 = Moderately matched, 1 = Weakly matched, (-) = Notmatched

Course Name: Mobile Communication and Network

Course Code:EC504A

Contacts:3:0:0

Total Contact hours: 36

Credits: 3

Prerequisite:Analog&DigitalCommunication

CourseOutcomes:

GraduatesoftheECEprogramwillbeable to:

CO1: DescribetheevolutionandHistoryofWirelessTechnology.

CO2: Explaincellularconceptformobilecommunication.

CO3: Learn radio signal propagation issues and different technological advancement of mobile communication,Wirelessand Radio channels.

CO4: Compare 3G Cellular telephone data transfer rates with those over Wireless LAN and core networks associatedwith3GCellularnetworks.

CO5: Describe mobile IP allocation and function of the station roaming. and describe the new key technologiesrelatedto 5G.

CourseContent:

ModuleI:INTRODUCTION[3L]

Evolution of mobile radio communications, mobile radio systems around the world, trends in cellular radio and personal communication, first generation (1G), second generation (2G), third generation (3G), Fourth Generation(4G) mobile cellular, 5G mobile cellular-Its use and underlying technologies to make up 5G, differences between the previous generations of mobile networks and 5G? How fast is 5G? Do I need a new phone if I want 5G?introduction to 6GKeyenablers

**ModuleII: CELLULARCONCEPT
[9L]**

Limitations of conventional mobile system, Introduction to mobile cellular communication, concept of frequency reuse, cluster size, cellular system architecture, channel assignment strategies, call handoff strategies - hard handoff and soft handoff, prioritizing handoff; interference and system capacity, improving capacity in cellular systems - cell splitting, sectoring, microcell zone concept, Co-channel interference, Propagation effects - scattering, ground reflection, fading

Module III: DIFFERENT MOBILE COMMUNICATIONS SYSTEMS

[6L]

GSM services and features, system architecture, GSM radio subsystem, GSM channel types, location updating and call setup, WAP, SCSD, GPRS, EDGE, 3G-W-CDMA; CDMA digital cellular standard

Module IV: WIRELESS NETWORKS

[8L]

Advantages and applications of Wireless LAN, WLAN technology - RF and IR wireless LAN, diffuse, quasi-diffuse and point-to-point IR wireless LAN, IEEE 802.11, IEEE 802.11 architecture, Introduction to WiFi,

HiPERLAN2, Bluetooth - Bluetooth architecture

Module V: MOBILE NETWORK

[6L]

Introduction to Mobile IP, requirements, IP packet delivery, Agent discovery, Registration, Tunneling and encapsulation, Optimization, Reverse tunneling; Mobile ad-hoc networks - Routing, Destination sequence distance vector, Dynamic source routing and Alternative metrics, 4G Introduction and vision, Multi antenna Technologies: MIMO; software defined radio, adaptive multiple antenna techniques, radio resource management, QoS requirements. ATM and SONET

Module VI: 5G-KEY TECHNOLOGIES:

[4L]

Small cells: Past, present, and future trends of cellular networks coverage and capacity of small cell networks Interference management, D2D architecture Towards IoT Spectrum sharing.

Massive MIMO: Point-to-point MIMO, Virtual MIMO (relaying), multiuser MIMO Massive MIMO

Textbooks:

1. Theodore S. Rappaport, Wireless communications: principles and practice, PHI/Pearson education.
2. J. Schiller, Mobile communications, Addison-Wesley.
3. William C. Y. Lee, Mobile cellular telecommunication – analog and digital systems, McGraw Hill, 2nd ed.

Reference Books:

1. Wang, Wireless communication System, Pearson Education
2. Talukdar, Mobile computing, TMH
3. J. W. Mark, W. Zhuang, Wireless Communication and Networking, PHI
4. A. Santamaria et al, Wireless LAN systems, Artech House
5. Stallings, Wireless Communication & Networks, Pearson Education.

CO-PO mapping:

	PO1	PO2	PO3	PO4	PO5	PO6	PO7	PO8	PO9	PO10	PO11	PO12	PSO1	PSO2	PSO3
CO1	3	2			1	3	2	2	2	3	2	1	3	2	2
CO2	2		2		3	2	2	2	3	2	3	2	3	2	2
CO3	2		3	3	3	2	1	2	3	1	3	1	2	2	2
CO4	2	2	3	3	3	3	2	2	3	2	3	1	3	2	1
CO5	2		2	3	3	2	2	2	3	2	3	2	2	1	2
AVG	2.6	2.4	1.8	1.5	2.5	2.5	1.25		2.5	1.7	2	1.6	1.6	1.8	1.8

Weightage Values: 3 = Strongly matched, 2 = Moderately matched, 1 = Weakly matched, (-) = Not matched.

Course Name: Fiber Optic Communication

Course Code: EC504B

Contacts: 3:0:0

Total Contact Hours: 36

Credit: 3

Pre-requisite:

Basic Concepts of communication, basic concepts of solid-state device and band theory (direct-indirect semiconductor, degenerate semiconductor), basics of Physics, Photodiode, LED etc.

Course Outcomes:

Graduates of the ECE program will be able to:

CO1: Recognize and classify the structures of Optical fiber and types.

CO2: Discuss the channel impairments like losses and dispersion.

CO3: Classify the Optical sources and detectors and to discuss their principle.

CO4: Familiar with Design considerations of fiber optic systems and to define the Wavelength Division Multiplexing (WDM) principles and concepts and to perform characteristics of optical fiber, sources and detectors.

CO5: To analyze optical fiber measurement systems.

Course Content:

Module 1:

[7L]

Introduction to communications systems: Principles, components

Different forms of communications in brief, advantages of optical fiber communication, Transmission Characteristics. Brief about current Industry trends in optical communications system.

Types of losses - Absorption losses, linear and nonlinear scattering losses, fiber bend losses, attenuation losses
Optical Fiber waveguide: Structure, Single and Multimode operation: basic concept with mathematical expression (no derivation is needed)

Attenuation, Material and wave guide dispersion.

Module2:

[8]

Components of Optical fiber communication systems- fiber connector and splicer, different types of fibers; Couplers-three and four port couplers-star couplers-optical fiber directional coupler; optical isolators, circulators, beam splitters and optical modulators.

Optical Sources: Light Emitting Diode; principle, structures, power and efficiency, coupling to fibers. Laser diodes: principle, double heterostructure, gain and index guiding, distributed lasers. Quantum Well Lasers; Modes and narrow linewidth lasers. Modulation; Bandwidth for modulation, Optical transmitters: component. Optical Detectors: Device types, optical detection principles, efficiency, responsivity, bandwidth. Preamplifiers; noise sources, signal to noise ratio.

Module3:

[11L]

Point-to-point link and Wavelength Division Multiplexing: Building blocks; Multiplexing; Intensity Modulation/Direct Detection system; Principle of Regeneration; WDM link, Optical amplifiers; EDFA, SOA, Raman amplifier.

Dispersion compensation and management.

Optical Network: LAN, MAN, WAN; Topologies: bus, star, ring; Ethernet; FDDI; Telecom networking: SDH/SONET. Different forms of access networks: Telephony; ISDN; Cable TV; Broadcast and Switched Networks; HFC networks; FTTC, FTTH and FTTN networks.

Module4:[9L]

Correlation of NA aperture measurements and mode field diameter. Measurements of distance using phase measurement, Displacement measurement, Optical disks, recording of audio & video signals on optical disks, mass replication by optical disk, direct read after write (DRAW), data readout, erasable optical disk, Holography, Attenuation measurements, Dispersion measurements, Refractive Index Profile Measurements, NA measurements, Polarization Depression Measurements, BER Measurements

Textbooks:

1. Optical Networks – Rajiv Ramaswami, K. N. Sivarajan, Galen H. Sasaki (Morgan-Kaufman)
2. Optical Fibre Communication : John M. Senior (Pearson)
3. Optical Communications: N. Bala Saraswathi, I. Ravi Kumar (Laxmi Publications)

Reference Books

1. Optical Communication Systems: John Gawarek (PHI)
2. Optical Fibre Communication: Gerd Kaiser (TMH)
3. Fiber Optics Communication by G. P. Agrawal.
4. Raman Amplifiers for Communications by M. N. Islam (Ed).

CO-PO Mapping:

COs/ POs	PO1	PO2	PO3	PO4	PO5	PO6	PO7	PO8	PO9	PO10	PO11	PO12	PSO1	PSO2	PSO3
CO1	3	3	2	2	2	1	-	-	-	-	-	-	-	-	2
CO2	3	2	3	1	2	-	-	-	-	-	-	1	-	-	-
CO3	3	3	2	1	1	-	-	1	-	1	-	-	-	-	1
CO4	3	3	2	1	2	1	1	-	1	-	1	-	-	-	-
CO5	3	2	3	1	2	1	-	1	-	1	2	1	-	-	1
AVG	3	2.6	2.4	1.2	1.8	1	1	1	1	1	1.5	1			1.3

Weightage Values: 3 = Strongly matched, 2 = Moderately matched, 1 = Weakly matched, (-) = Not matched.

CourseName: ELECTRONICS MEASUREMENT & INSTRUMENTATION

Course Code: EC504C

Contact:3:0:0

Total Contact Hours: 36

Credit:3

Prerequisites: Basic analog and digital electronic circuits and principles. Basic electronics engineering, Basic electrical engineering,

Course Outcomes:

Graduates of the ECE program will be able to:

CO1: Students able to explain the characteristics, construction and working principle analog instruments like PMMC, MI, Electro dynamometer type and Energy meter.

CO2: Students able to demonstrate the principle to measure resistance, capacitance, inductance with the help of Bridge balancing technique

CO3: Students able to describe the construction and working principle of electronic instrument like: DSO, DMM, spectrum analyzer, distortion meter

CO4: Student able to illustrate the functionality of sensor and transducer element

CO5: Student able to demonstrate the principle of working of Telemetry System Display device, Interface Standard, Data Acquisition system, Advanced Instruments Like OTDR, virtual instrument and PLC.

Module1:

[3L]

Characteristics of Instruments, Errors in Measurement, Units: Measurement Methods: Direct and Indirect Characteristics of Instrument & Measurement System: Static and dynamic, accuracy, precision, sensitivity, resolution, dynamic range, linearity, Hysteresis, repeatability, loading effect. Types of Error (concept): Gross Errors, Systematic Errors, Random Error Units and Standard in measurements – Concept of Calibration

Module2:

[6L]

Analog Instruments: Construction and operation of PMMC and Moving Iron type Instrument: Its application to measure current, voltage and resistance. Basic Construction and operation of Electro dynamometer type, rectifier type, thermocouple type instrument Construction and operation of Electro dynamometer type wattmeter and

single-phase induction type energy meter

Module3:[6L]

Measurement of resistance and AC Bridges: Wheatstone bridge, Kelvin double bridge, measurement of high resistance, Earth resistance measurement, localizing ground and short circuit fault. Potentiometer A.C. Bridges: Maxwell's Bridge – inductance, inductance – capacitance, Anderson's Bridge, DeSauty's Bridge, Schering Bridge, Wien's Bridge

Module4:[6L]

Electronic Instrument: Construction and operation of DMM, Function Generator, DSO, Frequency Counter, L-C-R. and Q-Meter, Distortion Meter, Spectrum Analyzer, resolution, sensitivity, and accuracy specification of digital meters.

Module5:[5L]

Sensing Element and Transducer: Components of transducer, Classification of electrical transducer with example, Working and application: Strain Gauges, Pirani Gauges, Semiconductor strain gauges, Thermistors, Thermocouple, IC temperature sensor, Inductive transducer, LVDT, Capacitive transducer, Piezo-electric transducer, LDR.

Module6:[5L]

Telemetry System, Display, Interface Standard: block diagram – land and R.F telemetry., Display Devices - Application of LED in display system, Fourteen Segment Display, Dot Matrix Display-3×5 dot, 27 dot, 5×7 dot, Application LCD in display system, Bus interface standard – GPIB interface bus (IEEE488)

Module7:[5L]

Data Acquisition and Advanced Instruments: Components of modern digital data acquisition system, Basic concept of PLC & Virtual Instrument, Fibre Optic Measurement – Splicing, OTDR, end to end loss measurement.

Textbook:

1. A.k.Sawhney, Electrical and Electronic Measurements and Measuring Instruments, Dhanpat Rai & Sons.

2. Helfrick, Cooper, Modern Electronic Instrumentation and Measurement Techniques, PHI Publication.

Reference Book:

1. J.B. Gupta, Electrical & Electronics Measurement and Instrumentation, SK Kataria Sons
Kalsi Electronic Instrumentation, Tatta McGraw-Hill

CO-PO Mapping:

COs\ POs	PO1	PO2	PO3	PO4	PO5	PO6	PO7	PO8	PO9	PO10	PO11	PO12	PSO1	PSO2	PSO3
CO1	3	1	2	2	2	-	-	-	1	1	1	2	1	-	-
CO2	3	2	1	2	1	-	-	-	1	2	1	2	1	2	-
CO3	3	3	3	2	3	-	-	-	1	2	2	3	-	-	-
CO4	3	3	3	3	3	2	2	2	2	2	1	3	1	-	-
CO5	3	2	2	2	3	2	2	2	3	2	3	3	-	2	-
	3	2.2	2.2	2.2	2.4	2	2	2	1.6	1.8	1.6	2.6	1	2	

Weightage Values: 3 = Strongly matched, 2 = Moderately matched, 1 = Weakly matched, (-) = Not matched.

Course Name: Satellite Communication

Course Code: EC504D

Contact: 3:0:0

Total Contact Hours: 36

Credit: 3

Course Outcomes:

Graduates of the ECE program will be able to:

CO1: Able to learn the orbital aspects of the satellite and the design of satellite links.

CO2: Able to understand the Satellite transponder and Earth Station Design

CO3: Able to understand Multiple Access Techniques used in satellite communication

CO4: Able to realize the various Propagation impairments on satellite communication

CO5: Able to comprehend satellite Navigation and the GPS, GIS and remote sensing

Course Content:

Module 1: Satellite Orbital Mechanics Launcher and Subsystems [8L]

Origin of Satellite communication, Current state of satellite communication. Orbital aspects of satellite communication: Orbital mechanism, equation of orbit, locating satellite in orbit, orbital elements, orbital perturbation, look angle, orbital period and velocity, azimuth and orbital inclination, coverage angle slant range, placement of satellite in geostationary orbit. Space craft subsystem: Attitude and orbit control system, Telemetry tracking and command system, power system, communication subsystem, antenna subsystems.

Module 2: Satellite Link Design [5L]

Basic link analysis, interference analysis, attenuation due to rain, link with and without frequency reuse. System noise temperature and G/T ratio, uplink design, downlink design, design of satellite link for specified C/N.

Module 3: Satellite Transponder and Earth Station Design [6L]

Transponder model, transponder channelization, frequency plans, processing transponders. Earth Station Technology: Earth Station design; Earth station antenna, gain, pointing loss, G/T variation and its measurement, antenna tracking, LNA, HPA, RF multiplexing, up converter, down converter, transponder hopping, polarization hopping, redundancy configuration, factors affecting orbit utilization, tracking, equipment for earth station.

Module 4: Multiple Access Techniques [6L]

Frequency Division Multiple Accesses: SPADE, FDM-FM-FDMA, Commanded FDM-FM-FDMA and SSB-AM-FDMA, inter modulation products in FDMA, optimized carrier-to-inter modulation plus noise ratio. Time division Multiple Access: Principle, TDMA frame structure, TDMA Burst structure, TDMA Super

frame structure, Frame acquisition and synchronization. TDMA timing. Demand Assignment Multiple Access

and Digital Speech interpolation. Type of demand assignment, DAMA characteristics, Real time frame reconfiguration, DAMA interfaces, SCPC-DAMA, CDMA, SDMA

Module 5: Propagation Effects on Satellite

[7L]

Earth's path – propagation effects, atmospheric absorption, Scintillation effects, Land and Sea multipath, Rain and ice effects, Rain drop distribution, calculation of attenuation. Rain effects on Antenna noise temperature. Encoding and forward error correction: Error detection and correction, channel capacity, error detecting codes - linear block codes, cyclic codes. Introduction to VSAT systems: Low earth orbit and non-geostationary satellite systems. Network error control using VSAT network. Mobile satellite network: Operating environment. MSAT network concept, CDMAMSAT relink. Worldwide timing by satellite relay. Direct broadcast Television DTH and Radio, Satellite Phone

Module 6: Satellite Navigation and Remote Sensing [4L]

Global Positioning System (GPS), Global Navigation Satellite Systems (GNSS), Basic concept of Geographic Information Systems (GIS), Idea of Remote Sensing

Text Books:

1. Timothy Pratt, Charles Bostian, Teremy Allnut, Satellite Communication, John Wiley & Sons.
2. "Satellite Communication", D.C. Agrawal, Khanna Publishers
3. "Satellite Communication", Dennis Roddy, 4th Edition, McGraw-Hill International edition, 2006
4. Monojit Mitra: Satellite communications, Prentice Hall of India

Reference Books:

1. "Satellite Communication", T.T. Hai., Mc. Graw Hill Publications
2. Satellite Communication Systems Engineering, W.L. Pitchand, H.L. Suyderhoud, R.A. Nelson, 2nd Ed., Pearson Education, 2007.
3. Satellite Communication, Mark R Chartrand, Cengage Learning
4. J.J. Spilker, Jr., Digital Communication by Satellite, Prentice Hall.
5. Bruce R. Elbert, Satellite Communication Applications Hand Book, Artech House.

CO-POMapping:

	PO1	PO2	PO3	PO4	PO5	PO6	PO7	PO8	PO9	PO10	PO11	PO12	PSO1	PSO2	PSO3
CO 1	-	1	1	1	1	1	2	--	-	2	2	1	3	2	-
CO 2	1	1	2	1	2	1	1	-	1	1	2	2	2	2	-
CO 3	-	-	-	1	1	2	1	-	2	1	1	2	2	2	-
CO 4	1	-	-	1	-	2	2	-	-	2	2	1	1	3	-
CO 5	1	1	2	1	2	1	1	-	1	1	2	2	3	2	-
AVG	1	1	1.7	1	1.5	1.4	1.4	-	1.3	1.4	1.8	1.6	2.2	2.2	-

Weightage Values: 3 =Strongly matched, 2= Moderatelymatched, 1=Weakly matched, (-)=Notmatched.

CourseName:ComputerArchitecture

CourseCode:EC505A

Contacts:3:0:0

TotalContactHours:36

Credit:3

Prerequisite: DigitalElectronics,AnalogElectronics,MicroprocessorandMicrocontroller,Sensors

CourseOutcomes:

GraduatesoftheECE programwillbeableto:

CO1:learnhowcomputerswork

CO2:know basicprinciplesofcomputer'sworking

CO3:analyzetheperformanceofcomputers

CO4:knowhowcomputersaredesignedandbuilt

CO5:understandissuesaffectingmodern processors(caches, pipelinesetc.)

CourseContent:

Module1:

Basic Structure of Computers, Functional units, software, performance issues software, machine instructions and programs, Types of instructions, Instruction sets: Instruction formats, Assembly language, Stacks, Ques, Subroutines.

[6L]

Module2: Processor organization, Information representation, number formats.

[4L]

Module3:

[10L]

Multiplication & division, ALU design, Floating Point arithmetic, IEEE 754 floating point formats, Control Design, Instruction sequencing, Interpretation, Hard wired control - Design methods, and CPU control unit. Microprogrammed Control - Basic concepts, minimizing microinstruction size, multiplier control unit. Microprogrammed computers - CPU control unit

Module4:[6L]

Memory organization, device characteristics, RAM, ROM, Memory management, Concept of Cache & associative memories, Virtual memory, System organization, Input-Output systems, Interrupt, DMA, Standard I/O interfaces

Module5: Concept of parallel processing, Pipelining, Forms of parallel processing, interconnect network [4L]

Module6:

VHDL basics programming concept, Structural, dataflow, behavioral & mixed style modeling techniques. [6L]

Text/Reference Books:

1. V. Carl Hamacher, "Computer Organisation", Fifth Edition.
2. A. S. Tanenbum, "Structured Computer Organisation", PHI, Third edition
3. Y. Chu, "Computer Organization and Microprogramming", II, Englewood Cliffs, N.J., Prentice Hall Edition
4. M. M. Mano, "Computer System Architecture", Edition
5. C. W. Gear, "Computer Organization and Programming", McGraw Hill, N. V. Edition
6. Hayes J. P., "Computer Architecture and Organization", PHI, Second edition

CO-PO Mapping:

Cos/POs	PO1	PO2	PO3	PO4	PO5	PO6	PO7	PO8	PO9	PO10	PO11	PO12	PSO1	PSO2	PSO3
CO1	3	-	1	2	-	2	-	-	-	-	-	3	1	-	-
CO2	-	2	-	3	-	1	-	-	-	-	-	3	-	-	-
CO3	2	-	-	-	2	-	3	-	-	-	-	3	-	-	-
CO4	3	-	1	-	-	-	2	-	-	-	-	3	1	-	-
CO5	3	-	2	-	-	2	1	-	-	-	-	3	-	-	-

Weightage Values: 3 = Strongly matched, 2 = Moderately matched, 1 = Weakly matched, (-) = Not matched.

Course Name: Digital Image & Video Processing

CourseCode:EC505B

Contact: 3:0:0

Total contact hour:36

Credits: 3

CourseOutcome:

GraduatesoftheECEprogramwillbeableto:

CO1: HaveaclearideaonDigitalImagingfundamentalsandImportanceofDigitalImageTransform.

CO2: UnderstandingtheimportanceofDigitalImageenhancementinspatialandfrequencydomainandfiltering techniques.

CO3: ExplainingtherequirementsandtypesofImageCompressionanditsstandards.

CO4: DemonstatethebasicconceptsofDigitalImageSegmentationandEdgedetectionofDigitalImages.

CO5: FamiliarizewithSecurityinDigitalImageProcessingandBasicStepsofVideoProcessingandits2Dmodeling.

Course Content:

Module1:[7L]

Digital Imaging Fundamentals: Basic idea of Digital image, Pixel, Mathematical operation of Digital Image, Sampling, Quantization, application of digital Image Processing Application of Artificial Intelligence/Machine Learning in Image and Video Processing[3]

Transform of Digital Images: Importance of Digital Image Transform, Fourier Transform of Digital Image (DFT), Inverse Fourier Transform (IDFT), Fast Fourier Transform, Inverse Fast Fourier Transform, Application of Digital Image Transform in different area[4]

Module2:[5L]

Digital Image Enhancement: Importance of Digital Image enhancement, enhancement in spatial and frequency domain, Bitplane slicing, Histogram, Histogram Equalization, Mean and Median filtering in Digital Images, Frequency domain filtering in Digital Images – LPF, HPF and BPF

Module3:[5L]

Digital Image Compression: Importance of Digital Image Compression, Types of Image Compression, example of lossless and lossy compression, Image compression standards, Compression in spatial domain, Wavelet based Digital image compression

Module4:[8L]

Segmentation of Digital Images: Importance and applications of Digital Image Segmentation, Detection of discontinuities, Segmentation based on Thresholding and Region Growing [4]

Edge detection in Digital Image

Processing: Importance of Edge detection in Digital Image Processing, Types of Edge Detection – sobel, canny and prewitt edge detection techniques and mathematical Equation of each operator. [4]

Module5:[4L]

Security in Digital Image Processing: Introduction to Digital Image Security and its application, Image encryption in spatial and frequency domain

Basic ideas on Cryptography, Steganography and Watermarking for digital image.

Module6:

[3L]

Introduction of Video Processing: Basic
 Steps of Video Processing: Analog video, Digital Video, Time varying Image Formation models,
 Geometric Image formation, filtering operations.

Module7:

[4L]

2-D Motion Estimation: Optical flow, general methodologies, pixel-based motion estimation, Mesh based motion estimation, global Motion Estimation, Region based motion estimation, multi resolution motion estimation. Waveform based coding, Application of motion estimation in video coding.

Textbooks:

1. Rafael C. Gonzales, Richard E. Woods, "Digital Image Processing", Third Edition, Pearson Education, 2010.
2. S. Annadurai, R. Shanmugalakshmi, "Fundamentals of Digital Image Processing", Pearson Education, 2006
3. Yao wang, Joem Ostarman and Ya-quin Zhang, "Video processing and communication", PHI

References:

1. Rafael C. Gonzalez, Richard E. Woods, Steven L. Eddins, "Digital Image Processing Using MATLAB", Third Edition Tata McGraw Hill Pvt. Ltd., 2011.
2. Anil Jain K. "Fundamentals of Digital Image Processing", PHI Learning Pvt. Ltd., 2011.
3. William K Pratt, "Digital Image Processing", John Wiley, 2002.
4. Malay K. Pakhira, "Digital Image Processing and Pattern Recognition", First Edition, PHI Learning Pvt. Ltd., 2011.
5. M. Tekalp, "Digital video Processing", Prentice Hall International

CO-PO-PSO MAPPING:

	PO1	PO2	PO3	PO4	PO5	PO6	PO7	PO8	PO9	PO10	PO11	PO12	PSO1	PSO2	PSO3
CO1	3	2		2			2		3	2	3		2	3	3
CO2	2	2	2			2		3	3	2	3	3	2	3	3
CO3	3	2		2	3	2	2		2		3	3	3	3	3
CO4	2	3	2	2		2			3	2	3		1	2	3
CO5	3	2		2				2	3		3		3	3	3
AVG	2.6	2.2	2	2	3	2	2	2.5	2.8	2	3	3	2.2	2.8	3

Weightage Values: 3 = Strongly matched, 2 = Moderately matched, 1 = Weakly matched, (-) = Not matched.

CourseName: EmbeddedSystem

Course Code: EC505C

Contacts:3:0:0

TotalContactHours:36

Credit:3

Prerequisite:DigitalElectronics,AnalogElectronics,MicroprocessorandMicrocontroller,Sensors, Actuators

CourseOutcomes:

GraduatesoftheECEprogramwillbeable to:

CO1:Know theoverviewofembeddedprocessors

CO2:Interfacethememorieswiththeembeddedprocessors

CO3:Interfasesensors andactuatorswiththeprocessors

CO4: Establish parallel and serial communication with the processors through highspeedwireless devices likeZigbee,Bluetooth,GSMmodulesetc.

CO5:Performrealtimeprojectswhichmaybebeneficialtothesociety

Course Content:

Module1:[5L]

Introductiontoembeddedsystems:concept,generalpurposeprocessors,MicroprocessorandMicrocontroller ,

RISCandCISCprocessors,ALU,Von-NeumannandHarvardarchitecture,watchdogtimer,realtimeclock

Module2: [10L]

OverviewofEmbeddedProcessorsandRTOS:Classification:GPP,SPP,MULTI-CORE,PopularMicrocontrollersusedinembeddedsystems-Atmega8/16/328Pprocessor,ARMCortex-

III processor, Microcontrollers Datasheet study, CPLD, FPGA, Embedded programming concepts in C, C++, JAVA, Hardware software co-design, Introduction to RTOS, Scheduling Techniques.

Module3:[5L]

Overview of Embedded Networking & Standards: RS232, RS485, SPI, I2C, U S B , PCI , CAN, Bluetooth, Zigbee

Module4:[6L]

Overview of Embedded Sensors and Transducers: Pressure, Temperature, Acceleration, Image, Rain, Proximity, Hall-effect, Ultra-sonic

Module5:[4L]

Overview of I/P-O/P devices & Interfacing: Keypad, TWS, JoyStick, SSL, LCD, VGA.

Module6:[6L]

Examples of Embedded System (Case Study): Mobile phones, IoT, RFID, WSN, Robotics, Biomedical Applications.

Textbooks:

1. Embedded Systems Architecture, Programming and Design, Ral Kamal, TMH, 2008.
2. Introduction to Embedded Systems: Shibu K. V. (TMH)
3. An Embedded Software Primer, D.E. Simon., Pearson Education, 1999.
4. Embedded Systems, Santanu Chattopadhyaya, Pearson
5. Embedded Systems: L.B. Das, Pearson

Reference Books:

1. Embedded Systems Design, Heath Steve, Second Edition-2003, Newnes,

2. Computers as Components; Principles of Embedded Computing System Design, Wayne Wolf Harcourt India, Morgan Kaufman Publishers, First Indian Reprint. 2001.
3. Embedded Systems Design – Unified Hardware/Software Introduction, Frank Vahid and Tony Givargis, John Wiley, 2002.
4. Design with PIC Microcontrollers, J.B. Peatman, Pearson Education, 1998

CO-PO Mapping:

	PO1	PO2	PO3	PO4	PO5	PO6	PO7	PO8	PO9	P10	P11	P12	PSO1	PSO2	PSO3
CO1	3	3	2	-	1	-	-	-	1	1	2	1	3	2	2
CO2	3	2	2	-	2	-	2	1	2	1	-	1	3	3	2
CO3	3	2	1	2	1	1	-	-	2	1	-	-	3	2	2
CO4	3	2	2	1	1	1	2	1	2	1	2	1	3	2	2
AVG	3	2.3	1.8	1.5	1.3	1	2	1	1.8	1	2	1	3	2.3	2

Weightage Values: 3 = Strongly matched, 2 = Moderately matched, 1 = Weakly matched, (-) = Not matched.

Course Name: Advanced Python Programming

Course Code: EC505D

Contacts: 3:0:0

Total Contact Hours: 36

Credit: 3

Prerequisite: Basic knowledge of Python.

Course outcome:

Graduates of the ECE program will be able to:

CO1: Able to understand Basic data types and variables, Basic operators, control statement, string operations, idea of list, tuples & dictionary, functions in Python.

CO2: Able to understand class, objects, Inheritance and Polymorphism using Python.

CO3: Able to illustrate exceptions, threads in Python.

CO4: Able to describe GUI using Python.

CO5: Able to understand networking and database handling using Python.

Course Content:

Module-1: Introduction to Python [4L]

Use IDLE to develop programs, Basic data types and variables, Basic operators, control statement, string operations, idea of list, tuples & dictionary, functions.

Module-2: Classes and objects: [4L]

Creating a class, self-variable, constructor, type of variables, namespace, instance method, class method, static method, passing member to one class to another class, inner class, descriptors and metaclasses.

Module-3: Inheritance and Polymorphism: [5L]

Department of Electronics & Communication Engineering

Constructors in inheritance, overriding superclass constructors and methods, the super() method, single and multiple inheritance, method resolution order, polymorphism, operator overloading, method overloading.

Module-4: Exceptions: [3L]

Errors in python, compile time, runtime error & logical error, exceptions, exception handling, types of exceptions, except block, assert statement, user defined exceptions, logging the exceptions.

Module-5: Files: [4L]

File descriptors, reading and writing files, working with text files, working with binary files, the "with" statement, pickle in python, seek() and tell() method, random accessing binary files using mmap, zipping and unzipping files, working with directories.

Module-6: Threads: [4L]

Single and multi-tasking, difference between process and thread, concurrent programming and GIL, uses of threads, creating a thread without using a class, creating a thread by creating a subclass to thread class, creating a thread without creating a subclass to thread class, thread class method, single tasking using a thread, thread synchronization, locks, semaphore, deadlock, communicating between threads.

Module-7: Graphical user interface: [4L]

Root window, fonts and colours, working with containers, canvas, frame, widgets, arranging widgets in the frame, label widget, message widget, text widget, scrollbar widget, checkbutton widget, entry widget, spinbox widget, listbox widget, menu widget.

Module-8: Networking: [4L]

TCP/IP protocol, user datagram protocol, sockets, knowing IP address, URL, reading the source code of a webpage, downloading a webpage from internet, downloading an image from internet, TCP/IP server, TCP/IP client, UDP server, File server, File client, two-way communication between server and client, sending mail.

Module-9:Database connectivity[4L]

Types of databases used in Python, Overview of MySQL , setting the path to MySQL server, InstallingMySQLconnector,retrieving all rowsfrom a table, insertingrows into table, deleting rowsfrom tableand updatingrows inatableusingPython,creatingdatabasetableusingPython.

TextBooks:

1. Python:TheCompleteReferencebyMartinCBrown
2. AdvancedPythonProgrammingbyLanaroDr.Gabriele
3. ExpertPythonProgrammingbyMichalJaworskiandTarekZiade.

Referencebooks:

1. Allen Downey, Jeff Elkner and Chris Meyers, (2017), How To Think Like A Computer Scientist:Learning WithPython,DreamTech
2. WesleyJChun,(2018),CorePythonProgramming,PrenticeHall

CO-POMapping:

CO	PO1	PO2	PO3	PO4	PO5	PO6	PO7	PO8	PO9	PO10	PO11	PO12	PSO1	PSO2	PSO3
CO1	2	2	3	1	1	-	-	1	2	1	1	1	3	2	2
CO2	3	3	3	3	1	-	-	1	2	1	1	3	3	3	2
CO3	3	3	3	2	1	-	-	1	2	1	1	3	3	2	2
CO4	3	3	3	1	1	-	-	1	2	1	1	3	3	2	2
CO5	3	3	3	2	1	-	-	1	2	1	1	2	2	2	2
AVG	2.8	2.8	3	1.8	1			1	2	1	1	2.4	2.8	2.2	2

WeightageValues:3 =Strongly matched,2 =Moderatelymatched,1 =Weaklymatched,(-)= Notmatched.

Course Name: Microprocessor and Microcontroller Lab

Course Code: EC591

Contact: 0:0:3

Credits: 1.5

Prerequisites: Knowledge in Digital Electronics

Course Outcome:

Upon the completion of the course the students will be able to

- CO1:** Solve small assignments using the 8085 basic instruction sets and memory mapping through trainer kit and simulator.
- CO2:** Write 8085 assembly language programs like Addition, Subtraction, Multiplication, Square, Complement, look up table, copying a block of memory, Shifting, Packing and unpacking of BCD numbers, Ascending order, Descending order etc. using trainer kit.
- CO3:** Validate the interfacing technique using 8255 trainer kits through subroutine calls and IN/OUT instructions like glowing LEDs accordingly, stepper motor rotation etc.
- CO4:** Test fundamental of 8051 programs using the trainer kit.

List of Experiments:

1. Familiarization with 8085 register level architecture, the basic instruction sets (data transfer, arithmetic, logical, branching) and the trainer kit components including the memory map.
2. Familiarization with the process of storing, executing, and viewing the contents of memory as well as registers in the trainer kit 8085 and simulator through small assignments.
3. Programming using 8085 kit and simulator for: Addition, Subtraction, Multiplication by repeated addition method, Square, Complement, look up table, Copying a block of memory, Shifting, Packing and unpacking of BCD numbers, Addition of BCD numbers, Binary to ASCII conversion, smallest and largest number from an array of numbers, Ascending order, Descending Order, String Matching, Multiplication using shift and add method.
4. Program using subroutine calls and IN/OUT instructions using 8255 PPI on the trainer kit e.g. subroutine for delay, reading switch state and glowing LEDs

Department of Electronics & Communication Engineering

accordingly, glowing of seven segment display.

5. Program for serial communication between two trainer kits.
6. Interfacing of 8255: Keyboard, Stepper motor rotation.
7. Study of 8051 Micro controller kit and writing programs.

Textbooks:

1. Microprocessor architecture, programming and application with 8085 – R. Gaonkar, Penram International
2. The 8051 microcontroller- K. Ayala, Thomson
3. Microprocessors & interfacing – D. V. Hall, Tata McGraw-hill
4. Ray & Bhurchandi, Advanced Microprocessors & Peripherals, TMH

5. The 8051 microcontroller and Embedded systems - Mazidi, Mazidi and McKinley, Pearson
6. An Introduction to Microprocessor and Applications – Krishna Kant, Macmillan.

Reference Books:

1. Microprocessors and microcontrollers - N. Senthil Kumar, M. Saravanan and Jeevananthan, Oxford university press
2. 8086 Microprocessor – K Ayala, Cengage learning
3. The 8051 microcontrollers – Uma Rao and Andhe Pallavi, Pearson

CO-PO-PSO Mapping:

	PO1	PO2	PO3	PO4	PO5	PO6	PO7	PO8	PO9	PO10	PO11	PO12	PSO1	PSO2	PSO3
CO1	3	3	3	1	-	-	-	-	3	2	-	-	3	1	-
CO2	3	3	3	1	-	-	-	-	3	2	-	-	1	3	-
CO3	3	3	3	3	-	-	-	-	3	2	-	-	3	1	-
CO4	3	3	3	3	-	-	-	-	3	2	-	3	3	3	1

Weightage Values: 3 = Strongly matched, 2 = Moderately matched, 1 = Weakly matched, (-) = Not matched.

Course Name: RF & Microwave Engineering Lab

Course Code: EC592

Contacts: 0:0:3

Credits: 1.5

Course Outcome:

Upon the completion of the course the students will be able to

CO1: Define, identify and list out special type transmission line, its characteristics in microwave frequencies and concept of load.

CO2: Recognize, memorize, categorize, arrange and implement suitably the various microwave passive devices with the utilization of engineering mathematics.

CO3: Analyses and use the various sources of microwave energy and the characters of its operation.

CO4: Use, compute, solve, demonstrate and apply various hardware, software tools and measuring instruments in the field of Radio Frequencies, for the betterment of communication engineering, medical science and various domestic and commercial engineering.

List of Experiments:

1. Determination of phase and group velocities in a waveguide carrying TE₁₀ Wave from Dispersion diagram [ω - β Plot].
2. Measurement of unknown impedance using shift in minima technique using a waveguide test bench/Measurement of the susceptance of an inductive and or a capacitive window using shift in minima technique using a waveguide test bench
3. Study of the characteristics of a Reflex Klystron oscillator
4. Study of Gunn-oscillator Characteristics using X-band waveguide test bench.
5. Measurement of coupling factor, Directivity, Insertion loss and Isolation of a Directional coupler using X-band waveguide test bench setup.
6. Scattering matrix of a magic tee/E-plane tee/H-plane tee using waveguide test bench at X-band.
7. Experimental/Simulation Study of filter (LPF, HPF, BPF) response.
8. Measuring of dielectric constant of a material using waveguide test bench at X-band.

Reference Books:

1. ML Sisodia & GS Raghuvanshi Basic Microwave Techniques and Laboratory Manual; Wiley Eastern Limited 1987
2. EL Gintzton Microwave Measurements, McGraw-Hill Book Co.
3. M Sucher and J Fox, Handbook of Microwave Measurements, Vol II, Wiley-Interscience Inc.

CO- PO-PSO Mapping:

	PO1	PO2	PO3	PO4	PO5	PO6	PO7	PO8	PO9	PO10	PO11	PO12	PSO1	PSO2	PSO3
CO1	3	3	3	1	-	-	-	-	3	2	-	3	3	1	-
CO2	3	3	3	1	-	1	-	-	3	2	-	3	-	-	-
CO3	3	3	3	3	-	-	-	-	3	2	-	3	3	1	-
CO4	3	3	3	3	3	-	-	1	3	2	-	3	3	3	-

Weightage Values: 3 =Strongly matched, 2 =Moderately matched, 1 =Weakly matched, (-)= Notmatched

CourseName: Mobile Communication and Network Lab

CourseCode: EC594A

Contacts: 0:0:3

Credits: 1.5

Course Outcome:

Graduates of the ECE program will be able to:

CO1: Understand the path Loss.

CO2: Analyze the Horizontal & vertical Beam Pattern of a Base station Antenna.

CO3: Understand the concept of co-channel interference and hence Signal to Interference and Noise Ratio.

CO4: Understand the impact of many different parameters influence the downlink C/I ratio like Cell radius, Tx power of B.S, Frequency reuse, Sectoring, Shadowing effect, B.S. height, Path loss exponent, Vertical beam tilt.

CO5: Study the effect of handover threshold and margin on SINR and call drop probability and handover probability.

List of experiments:

1. Calculation of received signal strength as a function of distance of separation, antenna height and carrier frequency.
2. To understand the impact of: - Transmitter Power, Path loss exponent, Carrier frequency, Receiver antenna height, Transmitter antenna height.
3. To calculate path loss exponent and variance of shadow fading from measurements and hence find the large-scale propagation's statistical characteristics.
4. To find the 3dB Bandwidth of a Base station Antenna.
5. To calculate the probability that the received signal level crosses a certain sensitivity level.
6. To understand the concept of co-channel interference and hence Signal to Interference and Noise Ratio: Downlink:

To calculate & plot SINR vs. distance at the MS for adaptation of the following parameters: Shadowing effect, Vertical Beam Pattern, Tilt Angle variation.

Uplink:

To calculate & plot SINR vs. distance at the MS for adaptation of the following parameters: Shadowing effect, Vertical Beam Pattern, Tilt Angle variation.

7. To understand the cellular frequency reuse concept fulfilling the following objectives: Finding the co-channel cells for a particular cell, Finding the cell clusters with in certain geographic area.
8. To study the effect of handover threshold and margin on SINR and call drop probability and handover probability
9. To study the outage probability, LCR & ADF in SISO for Selection Combining and MRC.
10. To study the effect of delay spread on frequency selectivity.
11. Evaluate (by computer simulations) and make analysis of the performance of various digital modulations as follows:
12. Design cellular FDMA/TDMA system to achieve a certain grade of service in terms of coverage and blocking probability.
13. Design cellular FDMA/TDMA system to achieve a certain grade of service in terms of coverage and blocking probability.
14. Characterization of radio Attenuation by means of propagation Models.

Textbooks:

1. Theodore S. Rappaport, Wireless communications: principles and practice, PHI/Pearson education.
2. J. Schiller, Mobile communications, Addison-Wesley.
3. William C. Y. Lee, Mobile cellular telecommunication – analog and digital systems, McGraw Hill, 2nd ed.

Reference Books:

1. Wang, Wireless communication System, Pearson Education
2. Talukdar, Mobile computing, TMH
3. J. W. Mark, W. Zhuang, Wireless Communication and Networking, PHI
4. A. Santamaria et al, Wireless LAN systems, Artech House.
5. Stallings, Wireless Communication & Networks, Pearson Education

CO-PO Mapping:

CO	PO1	PO2	PO3	PO4	PO5	PO6	PO7	PO8	PO9	PO10	PO11	PO12	PSO1	PSO2	PSO3
CO1	3	2	-	-	1	3	2	2	2	3	2	1	2	2	2
CO2	2	-	2	-	3	2	2	2	3	2	3	2	2	2	1
CO3	2	-	3	3	3	2	1	2	3	1	3	1	3	2	2
CO4	2	2	1	-	2	3	2	2	3	2	3	-	3	2	1
CO5	2	-	3	3	3	2	2	2	3	1	3	1	2	1	2
AVG	2.2	2	2.3	3	2.4	2.4	1.8	2	2.8	1.8	2.8	1.25	2.4	1.8	1.6

Weightage Values: 3 = Strongly matched, 2 = Moderately matched, 1 = Weakly matched, (-) = Not matched.

CourseName:FiberOpticCommunicationLab

CourseCode:EC594B

Contacts:0:0:3

Credits: 1.5

CourseOutcome:

GraduatesoftheECEprogramwillbeableto:

CO1: Basicknowledgeabouttheinputoutputcharacteristics.

CO2:Able to define and analyze the attenuation constant, bending loss.

CO3:Able to define, analyze and draw V-I characteristics of optical fiber.

CO4:Abletodefine,analyze anddrawP-Icharacteristicsofopticalfiber.

ListofExperiments:

1. Demonstrateandstudy ofdifferenttypes ofOpticalfibersandconnectors.
2. Toestablishandstudyofa 650nmfiber opticanaloglinkanddigital link.
3. Input-outputcharacteristicsusinglongopticalfiber.Calculationofattenuationperunitlengthofopticalfiber
4. Tocalculate attenuationconstant,bendingloss.
5. I-VcharacteristicsofLED(i)usingopticalfiber betweenLEDandpowermeterand(ii)withoutusing opticalfiber.
6. P-IcharacteristicsofLED(i)usingopticalfiberbetweenLEDandpowermeterand(ii)withoutusing opticalfiber.
7. Tomeasurepropagationlossinopticalfibreuseingopticalpowermeter.
8. Tomeasurethe NumericalAperture (NA)ofthefibre

Textbook

1. Optical Networks –Rajiv Ramaswami, K. N. Sivarajan, Galen H. Sasaki (Morgan-Kaufman)
2. Optical Fibre Communication :John M. Senior(Pearson)
3. Optical Communications: N.BalaSaraswathi, I.RaviKumar(LaxmiPublications)

Reference Books

1. Optical Communication Systems:JohnGawar(PHI)
2. Optical Fibre Communication :Gerd Kaiser(TM)
3. Fiber optics communication by G.PAgrawal.
4. Raman Amplifiers for communications by M.N.Islam(Ed).

CO-PO Mapping

COs\ POs	PO1	PO2	PO3	PO4	PO5	PO6	PO7	PO8	PO9	PO10	PO11	PO12	PSO1	PSO2	PSO3
CO1	3	3	2	2	2	1	-	-	-	-	-	-	1	-	-
CO2	3	2	3	1	2	-	-	-	-	-	-	1	-	-	-
CO3	3	3	2	1	1	-	-	1	-	1	-	-	1	-	-
CO4	3	3	2	1	2	1	1	-	1	-	1	-	-	-	-

Weightage Values: 3 =Strongly matched, 2 =Moderately matched, 1 =Weakly matched, (-)= Not matched.

Course Name: Measurement and Instrumentation Laboratory

Course Code: EC594C

Contact: 0:0:3

Credit: 1.5

Prerequisites: Concepts of different measuring system.

Course Outcome:

Graduates of the ECE program will be able to:

CO1: Conduct experiment to measure of Resistance, Inductance, Capacitance, Power and Energy.

CO2: Students able to demonstrate the principle to measure resistance, capacitance, inductance with the help of Bridge balancing technique

CO3: Students able to describe the construction and working principle of electronic instrument like: DSO, DMM, spectrum analyzer, distortion meter

CO4: Student able to illustrate the functionality of sensor and transducer element

CO5: Student able to demonstrate the principle of working of Telemetry System Display device, Interface

CO6: Standard, Data Acquisition system, Advanced Instruments Like OTDR, virtual instrument and PLC.

List of Experiment:

1. Measurement of power in polyphase circuit.
2. Measurement of power using instrument transformer.
3. Measurement of capacitance using Schering Bridge technique as well as LCR meter.
4. Calibration of Digital Energy Meter.
5. Testing of energy Meter
6. Measurement of capacitance using Anderson Bridge technique as well as LCR meter.

7. Measurement of low resistance using Kelvin Double bridge.
8. Measurement of high resistance and insulation resistance using Megger.
9. Usage of DSO to capture transient like step change in R-L-C circuit.
10. Current measurement using shunt, CT and Hall Sensor
11. Measurement of capacitance by Deauty bridge
12. Measurement of frequency by Wien Bridge.
13. Innovative Experiment

Text Book:

1. A.k.Sawhney, Electrical and Electronic Measurements and Measuring Instruments
, Dhanpat Rai & Sons.
2. Helfrick, Cooper, Modern Electronic Instrumentation and Measurement Techniques, PHI Publication.

Reference Book:

1. J.B. Gupta , Electrical & Electronics Measurement and Instrumentation , SK Kataria
Sons Kalsi
, Electronic Instrumentation, Tatta McGraw-Hill

CO-PO Mapping:

COs\ POs	PO1	PO2	PO3	PO4	PO5	PO6	PO7	PO8	PO9	PO1 0	PO1 1	PO1 2	PSO1	PSO2	PSO3
CO1	3	1	2	2	2	-	-	-	1	1	1	2	-	-	-
CO2	3	2	1	2	1	-	-	-	1	2	1	2	-	-	-
CO3	3	3	3	2	3	-	-	-	1	2	2	3	-	-	-
CO4	3	3	3	3	3	2	2	2	2	2	1	3	-	-	-
CO5	3	2	2	2	3	2	2	2	3	2	3	3	-	-	-
CO6	3	2	2	2	2	2	2	2	2	2	2	2	-	-	-

Weightage Values: 3 = Strongly matched, 2 = Moderately matched, 1 = Weakly matched, (-) = Not matched.

Course Name: Satellite Communication Laboratory

Course Code: EC594D

Contacts: 0:0:3

Credit: 1.5

Course Outcomes:

On completion of the course students will be:

CO1: Able to learn the orbital aspects of the satellite and the design of satellite links.

CO2: Able to understand the Satellite transponder and Earth Station Design.

CO3: Able to understand Multiple Access Techniques used in satellite communication.

CO4: Able to realize the various Propagation impairments on satellite communication.

CO5: Able to comprehend satellite Navigation and the GPS, GIS and remote sensing.

List of Experiments:

1. To Study Satellite Trainer kit.
2. To set up an active satellite link and demonstrate link fail operation.
3. To communicate voice signal through satellite link.
4. To establish analog /digital Communication link and transmit and receive three Signals (audio, video, tone) simultaneously using satellite communication trainer.
5. To transmit and receive PC data through satellite link.
6. To find the link C/N Ratio
7. Evaluation of SNR in Satellite Links
8. To observe effect of Fading margin of received signal in satellite link
9. To Study Analysis of Link Power Budget Equation.
10. To study any software simulation tool for satellite Navigation and remote sensing.

Textbooks:

1. Timothy Pratt, Charles Bastian, Tarmey All Nutt, Satellite Communication, John Wiley & Sons.
2. "Satellite Communication", D.C. Agrawal, Khanna Publishers
3. "Satellite Communication", Dennis Roddy, 4th Edition, McGraw-Hill International Edition, 2006
4. Monojet Mitra: Satellite Communications, Prentice Hall of India

Reference Books:

1. "Satellite Communication", T.T. Hai., McGraw Hill Publications
2. Satellite Communication Systems Engineering, W. L. Pitch and, H. L. Suyderhoud, R. A. Nelson, 2nd Ed., Pearson Education, 2007.
3. Satellite Communication, Mark R Chartrand, Cengage Learning
4. J.J. Spilker, Jr., Digital Communication by Satellite, Prentice Hall.
5. Bruce R. Elbert, Satellite Communication Applications Handbook, Artech House.

CO-PO Mapping:

	PO1	PO2	PO3	PO4	PO5	PO6	PO7	PO8	PO9	PO10	PO11	PO12	PSO1	PSO2	PSO3
CO 1	2	2	2	2	3	2	1		2	2	3	3	2	3	
CO 2	2	3	3	3	3	1	1		2	2	3	3	2	3	
CO 3	3	3	2	3	3	2	2		3	3	3	3	3	3	
CO 4	3	3	2	2	2	1	1		1	1	2	3	1	2	
CO 5	2	2	2	2	3	2	1		2	2	3	3	3	3	
AVG	2.4	2.6	2.2	2.4	2.8	1.6	1.2		2	2	2.8	3	2.2	2.8	

Weightage Values: 3 = Strongly matched, 2 = Moderately matched, 1 = Weakly matched, (-) = Not matched.

CourseName:ComputerArchitectureLab

CourseCode: EC595A

Contacts:0:0:3

Credit:1.5

Prerequisite:DigitalElectronics,AnalogElectronics,MicroprocessorandMicrocontroller,Sensors,C/C++programming,Python/JavaScriptprogramming

CourseOutcomes:

GraduatesoftheECEprogramwillbeableto:

CO1:learnVHDLprogramming

CO2:implementarithmetic circuitsusingVHDLprogramming

CO3:implementRAMandROMarchitectures

CO4: designregister,counterandcontrolunit

CO5:implementcomplexprojectsrelatedtocomputerarchitecture

CourseContent

1. IntroductiontoHDLprogramming(includesdifferentmodelingstylesandprogramming structure)
2. Programmingofbasicgates (AND, OR,NAND,NOR,XOR, XNOR)withHDL
3. Designofhalfadder,halbsubtractor,fulladderandfullsubtractor
4. 8-bitAdder(ParallelAdder),Subtraction(ParallelSubtractor/1's complement/2'scomplementtechnique)
5. Multiplication(Arraybaseddesign/ Radix-2Booth'salgorithm/ Karatsuba technique), Division(Restoring/Non-Restoring algorithm)
6. Designofflipflops (D,TandJK)

7. 8-bit Register design (with left and right shift feature)
8. 8-bit RAM design with op code fetching and data fetching
9. 8-bit simple ALU design
10. 8-bit simple CPU design

Text/Reference Books:

1. V. Carl Hamacher, "Computer Organisation", Fifth Edition.
2. A.S. Tanenbum, "Structured Computer Organisation", PHI, Third edition
3. Y. Chu, "Computer Organization and Microprogramming", II, Englewood Cliffs, N.J., Prentice Hall Edition
4. M.M. Mano, "Computer System Architecture", Edition
5. C.W. Gear, "Computer Organization and Programming", McGraw Hill, N.V. Edition
6. Hayes J.P., "Computer Architecture and Organization", PHI, Second edition

CO-PO Mapping:

	PO 1	PO 2	PO3	PO4	PO5	PO6	PO7	PO8	PO9	PO1 0	PO1 1	PO1 2	PSO1	PSO2	PSO3
CO1	2	-	1	-	-	3	-	2	-	1	-	3	1	-	-
CO2	-	3	-	2	-	1	-	-	2	-	2	3	1	-	-
CO3	3	-	-	-	1	-	3	1	-	1	-	3	-	-	-

CO4	2	-	1	-	3	-	2	-	2	-	2	3	-	-	-
CO5	3	-	1	-	-	3	2	-	-	-	-	3	-	-	-

Weightage Values: 3 =Strongly matched, 2 =Moderatelymatched, 1 =Weaklymatched, (-)= Notmatched.

CourseName:DigitalImage&VideoProcessingLab

Course Code: EC595B

Contacthour:0:0:3

Credits:1.5

CourseOutcome:

GraduatesoftheECEprogramwillbeableto:

- CO1:** Build knowledge on Digital Imaging fundamentals and Digital Image Transform.
- CO2:** Understanding Digital Image enhancement techniques in spatial and frequency domain
- CO3:** Explaining therequirementsandtypesofImageCompression andits standards.
- CO4:** DemonstratetheSegmentationandEdgedetectiontechniquesofDigitalImages
- CO5:** BuildideasonDigitalImagesecurityand BasicStepsofVideoProcessing

ListofExperiments:

1. ConvertRGBDigitalImagesintoGrayscaleImagesandshowresult.
2. Transformagrayscaleimageintofrequencydomainandshowitsmagnitudeandphaseangle.
3. Displayhistogramofadigitalimageandequalizedtheimage.
4. ApplyLPFandHPFinaGrayscaleDigitalImageanddisplayresult.
5. ApplyMeanandMedianfilteringinaGrayscaleDigitalImageanddisplayresult.
6. CompressandreconstructaGrayscaleDigitalImagesinspatialdomain.
7. CompressandreconstructaGrayscaleDigitalImageinfrequencydomain.
8. Applysegmentationtechnique (anyone)inaDigitalImageanddisplayresult.

9. Apply EdgedetectiontechniqueinaDigitalImageanddisplayresult.
10. Applyanycryptographyor watermarkingtechniqueforimageencryptionanddisplayresult.
11. Experimentofdivisionofavideointoframes
12. ExperimentonFrequencydomainmotionestimation
13. ExperimentonKernelbasedtracking
14. Experimentonvideoshortboundarydetection
15. Innovative experiment

Textbooks:

1. RafaelC.Gonzales, RichardE. Woods, “DigitalImageProcessing”, ThirdEdition, PearsonEducation, 2010.
2. S. Annadurai, R. Shanmugalakshmi, “Fundamentals of Digital Image Processing”, Pearson Education, 2006
3. Yao wang, Joem Ostarmann and Ya-quin Zhang, “Videoprocessing and communication”, PHI

References:

1. RafaelC. Gonzalez, RichardE. Woods, StevenL. Eddins, “DigitalImageProcessing Using MATLAB”, Third Edition Tata McGraw Hill Pvt. Ltd., 2011.
2. Anil Jain K. “Fundamentals of Digital Image Processing”, PHI Learning Pvt. Ltd., 2011.
3. William K Pratt, “Digital Image Processing”, John Willey, 2002.
4. Malay K. Pakhira, “Digital Image Processing and Pattern Recognition”, First Edition, PHI Learning Pvt. Ltd., 2011.
5. M. Tekalp, “Digital video Processing”, Prentice Hall International

CO-PO-PSO Mapping:

	PO 1	PO 2	PO 3	PO 4	PO 5	PO 6	PO 7	PO 8	PO 9	PO1 0	PO1 1	PO1 2	PSO 1	PSO 2	PSO 3
CO1	3	2	-	2	-	-	2	-	3	2	-	-	2	3	2
CO2	2	2	2	-	-	-	-	-	3	2	-	3	2	3	2
CO3	3	2	-	2	3	-	2	-	2	2	-	3	3	3	2
CO4	2	3	2	2	-	-	-	-	3	2	-	-	1	2	2
CO5	3	2	-	2	-	-	-	-	3	2	-	-	3	3	3

Weightage Values: 3 =Strongly matched, 2 =Moderatelymatched, 1 =Weaklymatched, (-)= Notmatched.

CourseName:EmbeddedSystemLab

CourseCode: EC595C

Contacts:0:0:3

Credit:1.5

Prerequisite:DigitalElectronics,AnalogElectronics,MicroprocessorandMicrocontroller,Sensors,C/C++programming,Python/JavaScriptprogramming

Course Outcomes:

Upon the completion of the course the students will be able to

CO1: Understand the Program embedded processors

CO2: Interface the memories with the embedded processors

CO3: Interface sensors and actuators with the processors

CO4: Establish parallel and serial communication with the processors through high speed wireless devices like Zigbee, Bluetooth, GSM modules etc.

CO5: Perform real time projects which may be beneficial to the society

Course Content

1. Programming withARMprocessor/RaspberryPi/Arduino:

- i) IntroductiontoRaspberryPiandArduinoprogramming
- ii) LEDinterfacingwithRaspberryPi/Arduino
- iii) ProximitysensorinterfacingwithRaspberry Pi/Arduino
- iv) UltrasonicsensorinterfacingwithRaspberryPi/Arduino
- v) ServomotorinterfacingwithRaspberry Pi/Arduino
- vi) SevensegmentdisplayinterfacingwithRaspberryPi/Arduino
- vii) ADCandDACinterfacingwithRaspberryPi/Arduino
- viii) TrafficlightmanagementwithRaspberryPi/Arduino
- ix) Anyinnovativeexperiments

2. Programming withAtmega8/16/328Pprocessor:

- i) LED interfacing with Atmega8/16/328P
- ii) Proximity sensor interfacing with Atmega8/16/328P
- iii) Ultrasonic sensor interfacing with Atmega8/16/328P
- iv) Temperature and Humidity sensor interfacing with Atmega8/16/328P
- v) Servomotor interfacing with Atmega8/16/328P
- vi) Seven segment display interfacing with Atmega8/16/328P
- vii) Serial communication with Atmega8/16/328P
- viii) Bluetooth interfacing with Atmega8/16/328P
- ix) GSM interfacing with Atmega8/16/328P

3. Any innovative experiments

4. Programming with FPGA:

- i) Introduction to VHDL programming
- ii) Data type and library declaration
- iii) Different styles of programming: Dataflow, Behavioral and Structural
- iv) Loop concepts and array declaration
- v) Combinational circuits design
- vi) Sequential circuits design
- vii) FSM implementation
- viii) Interfacing FPGA board with sensors

Textbooks:

1. An Embedded Software Primer, D.E. Simon., Pearson Education, 1999.
2. Design with PIC Microcontrollers, J.B. Peatman, Pearson Education, 1998
3. VHDL Primer, J. Bhaskar, Pearson Education, 3rd Edition

Reference Books:

1. DigitalSystemsDesignUsingVHDL,CharlesH.Roth,Jr.,PWSPublishingCompany
2. ComputersasComponents;PrinciplesofEmbeddedComputingSystemDesign,WayneWolfHarcourtIndia, Morgan KaufmanPublishers, FirstIndianReprint.2001.

CO-PO-PSO Mapping:

	PO1	PO2	PO3	PO4	PO5	PO6	PO7	PO8	PO9	PO10	PO11	PO12	PSO1	PSO2	PSO3
CO1	3	3	2	-	1	-	-	-	1	1	-	1	3	2	-
CO2	3	2	2	-	-	-	-	1	2	1	-	1	3	3	-
CO3	3	2	1	2	1	1	-	-	2	1	-	-	3	2	-
CO4	3	2	2	1	1	1	-	1	2	1	1	1	3	3	-

WeightageValues:3=Stronglymatched,2=Moderatelymatched,1=Weaklymatched,(-)=Notmatched.

Course Name: Advanced Python Programming Lab

Course Code:EC595D

Contact: 0:0:3

Credits: 1.5

Course outcome:

Upon the completion of the course the students will be able to

CO1: Understand class and objects

CO2: Analyze exceptions and threads

CO3: Evaluate polymorphism

CO4: Apply GUI using Python

CO5: Apply networking and database using Python

List of Experiments:

1. Write a Python program to import built-in array module and display the namespace of the said module.
2. Write a Python program to create a class and display the namespace of the said class.
3. Write a Python program to create an instance of a specified class and display the namespace of the said instance.
4. Using init method implement a constructor.
5. Write Python program to implement inheritance.
6. Create a Python class named Circle constructed by a radius and two methods which will compute the area and the perimeter of a circle.
7. Insert and delete data from a linked list using Insert and Delete class.
8. Write Python program to implement Polymorphism.
9. Write Python program to override Magic Methods.
10. Write Python program to create a simple calculator, where the user will enter a number in a text field, and either add it to or subtract it from a running total, which we will display. We will also allow the user to reset the total.
11. Implement thread-based parallelism using Python
12. Networking using socket module implementing a server and client.
13. Create MySQL database and retrieving all rows from a table, inserting rows into a table, deleting rows from a table and updating rows in a table using Python.

Textbooks:

1. Python: The Complete Reference by Martin C Brown
2. Advanced Python Programming by Lanaro Dr. Gabriele
3. Expert Python Programming by Michal Jaworski and Tarek Ziade.

Referencebooks:

1. Allen Downey, Jeff Elkner and Chris Meyers, (2017), How To Think Like A Computer Scientist: Learning With Python, DreamTech
2. Wesley J Chun, (2018), Core Python Programming, Prentice Hall

CO-PO-PSO Mapping:

COs	PO1	PO2	PO3	PO4	PO5	PO6	PO7	PO8	PO9	PO10	PO11	PO12	PSO1	PSO2	PSO3
CO1	3	3	3	3	3	2	-	-	3	2	-	2	1	2	3
CO2	3	3	3	3	3	2	2	-	3	2	-	2	2	2	3
CO3	3	3	3	3	3	2	-	-	3	2	-	2	1	3	3
CO4	3	3	3	3	3	2	1	-	3	2	-	2	3	2	3
CO5	3	3	3	3	3	2	-	-	3	2	-	2	2	1	3

Weightage Values: 3=Strongly matched, 2=Moderately matched, 1=Weakly matched, (-)=Not matched.

Stream: ECE

Subject Name: MinorProject-I

Subject Code: PR591

Contact hour: 2P

Total contact hour- 20

Credits: 1

Prerequisite: Course completed up to 4th semester in UG ECE

Course Objective:

Prepare students with foundation knowledge in a project domain through surveying, designing, implementing, observing and reporting.

Methodology:

1. Thinking: Discussion on innovative idea.
2. Exploring: Survey of recent research.
3. Implementing: Project guidance to basic prototype implementation.
4. Documenting: Guidance on reporting and conference paper writing.
5. Each Minor Project-I group should submit the following under their semester project report submission with items not limited to,

Title, certificates, declaration by student, acknowledgement, Table of Contents, abstract, keywords, Introduction, Literature Survey, System Analysis (if applicable), System Design (if applicable), Coding, Testing (if applicable), Conclusion, Future Scope of work), reference

Course outcome:

Sem. No.	Course Title (Code)	CO Codes	Course Outcomes
			On completion of the course students will be able to
5 th	Minor Project-I (PR591)	CO1	Apply the knowledge acquired through survey of recent research to set the project goal.
		CO2	Distinguish the way of implementation of prototype
		CO3	Identify the fault issue through various case study
		CO4	Implement the prototype using modern tools
		CO5	Demonstrate the project design to share the idea through conference/workshop/seminar etc.

CO-PO-PSO MAPPING:

COs\POs	PO1	PO2	PO3	PO4	PO5	PO6	PO7	PO8	PO9	PO10	PO11	PO12	PSO1	PSO2	PSO3
CO1	3	3	3	2	1	1	3		1	1		3	2	3	
CO2	3	3	3	3	3			3	3		2	3	3	3	2
CO3	2		3	3	2	2	3	3	2	2		3	3	2	1
CO4	1	3	3	2	3		3	2	3		2	3	3	3	3
CO5	3		2	3	3	2		3	3	2		3	3	3	2
AVG	2.4	3	2.8	2.6	2.4	1.67	3	2.75	2.4	1.67	2	3	2.8	2.8	2

Stream: ECE

Subject Name: Skill Development V: Soft Skill & Aptitude-II

Subject Code: PR592

Contact hour:1P

Total contact hour- 10

Credits: 0.5

Prerequisite: Course completed up to 4th semester in UG ECE

Objective:

Business Communication: To improve Communications skills, current English usage, debates, language games, situational dialogues, precis writing, essay writing, presentations.

Presentation Skills: To prepare for effective presentations, presentation for small groups and large groups, marketing and business presentations.

Business Correspondence: To explore the hidden potential of clear writing by identifying misused words, applications and requests, positive and negative responses to requests, routine messages, memos, report writing, organizing meetings, preparation of agenda and minutes, business etiquette, telephone etiquette, e-mail etiquette.

Benefits from the Training: To unveil the ability to communicate clearly and concisely as an advantage to a promising manager. The students will soon realize that fluency and command over speaking and writing gives them an edge while interacting with people at all levels.

Behavioral Skills: to identify an array of skills related to personal growth for efficient functioning constitutes the training. Students are made to realize their strengths and weaknesses so that they are able to grasp the true essence of development. They are made to take part in role plays, games, and puzzles that demonstrate the attributes needed for assertiveness, interpersonal relationships, negotiations, time and goal management, leadership skills, and conflict management.

Course outcome:

Sem. No.	Course Title (Code)	CO Codes	Course Outcomes
			On completion of the course students will be able to
5 th	Skill Development V: Soft Skill & Aptitude-II (PR592)	CO1	Activate teamwork through learning to connect and work with others to achieve goal for a set task
		CO2	Build responsibility for one's self, learning self-reliance and independence.
		CO3	Communicate and demonstrate with clear briefing and listening skills, not being afraid to ask for help and support when necessary
		CO4	Construct emotional maturity and emotional health by learning to handle emotions including tolerance and behavioural responses, building positive friendships and bonding with peers and classmates, learning to show understanding and to demonstrate respect for the opinions, personal space and beliefs of others
		CO5	Explore Leadership quality by assessing the requirements of a task, identifying the strengths within the team, utilising the diverse skills of the group to achieve the set objective, awareness of risk/safety
		CO6	Grow confidence and enthusiasm for learning by developing self-motivation, raised aspirations and belief in one's own abilities, defining and committing to achieving one's goals

CO-PO-PSO MAPPING:

COs/POs	PO1	PO2	PO3	PO4	PO5	PO6	PO7	PO8	PO9	PO10	PO11	PO12	PSO1	PSO2	PSO3
CO1	3	3	3	2	1	1	3		1	1		3	2	3	
CO2	3	3	3	3	3			3	3		2	3	3	3	2
CO3	3		2	3	3	2		3	3	2		3	3	3	2
CO4	2		3	3	2	2	3	3	2	2		3	3	2	1
CO5	1	3	3	2	3		3	2	3		2	3	3	3	3
CO6		2	3	3	3	2	3	3	3			3	3		2
AVG	2.4	2.75	2.83	2.67	2.5	1.75	3	2.8	2.5	1.67	2	3	2.8333	2.8	2

CourseName:ConstitutionofIndia

CourseCode:MC 501

Contacts:2:0:0

Total Contact Hours: 24

Credit:0

Prerequisite:None

CourseOutcomes:

GraduatesoftheECEprogramwillbeableto:

CO1:Identifyandexplore the basicfeaturesandmodalitiesofIndianconstitution.

CO2:DifferentiateandrelatethefunctioningofIndianparliamentarysystematthecentreandstatelevel.

CO3:Differentiatethe variousaspectsofIndianLegalSystemanditsrelatedbodies.

CO4: Understand the structure and composition of Indian constitution.

CourseContent

Module1:Introduction:

[4]

“Constitution”-

HistoricalBackgroundoftheConstituentAssembly,IndianConstitutionanditsSalientFeatures,thePreambleoftheConstitution.

Module2:FundamentalRights,FundamentalDuties,Directive PrinciplesofState Policy:

[8]

TheRighttoEquality

The RighttoFreedom:I(Article19)

The Right to Freedom: II (Articles 20, 21 and 22)TheRightagainstExploitation

The Right to freedom of ReligionCultural and Educational rightsTheRightto Property

TheRighttoConstitutionalRemediesTheDirectivePrinciplesFundamentalDuties

Module3: Union Government and its Administration

[6]Stru

State Relations, Amendment of the Constitutional Powers and Procedure, The historical perspectives of the constitutional amendments in India, Emergency Provisions: National Emergency, President Rule, Financial Emergency, and Local Self Government – Constitutional Scheme in India.

Module4: The Machinery of Government in the State

[6]Pow

–The Independence of the Supreme Court, Appointment of Judges

State Executives –

Powers and Functions of the Governor, Powers and Functions of the Chief Minister, Functions of State Cabinet, Functions of State Legislature, Functions of High Court and Subordinate Courts.

Text/Reference Books:

1. Indian Constitution by D.D. Basu, The Publisher, Lexis Nexis
2. Constitution of India by Subhas Chandra Bose, Vitasta Publishing
3. The Constitution of India, P.M Bakshi, Universal Law Publishing Co. Ltd, New Delhi, 2003.
4. Indian Constitution Text Book - Avasthi, Avasthi, Publisher: LAKSHMINARAINAGARWAL

CO-POMapping:

COs\POs	PO1	PO2	PO3	PO4	PO5	PO6	PO7	PO8	PO9	PO10	PO11	PO12
CO1	3	-	2	2	-	2	-	3	-	1	3	3
CO2	3	2	-	1	-	1	-	2	2	3	3	3
CO3	3	-	1	-	-	3	-	2	-	1	3	3
CO4	2	2	-	1	-	1	-	2	2	3	3	3

Weightage Values: 3 =Strongly matched, 2 =Moderatelymatched, 1 =Weaklymatched, (-)= Notmatched.

R21(B.TechECE)**CurriculumforB.Tech****UnderAutonomy****Electronics&CommunicationEngineering****(EffectiveFrom2021-22admissionBatch)****L–Lecture;T-Tutorial;P-Practical[1L=1Cr,1T=1Cr,1P=0.5Cr]****3rdYear2ndSemester:6thSemester**

Sl. No.	Category	CourseCode	CourseTitle	Hoursperweek				Credits /Unit
				L	T	P	Total	
A.THEORY								
1	HSMC	HSMC604	EconomicsforEngineers	2	0	0	2	2
2	PC	EC601	VLSI& Microelectronics	3	0	0	3	3
3	PC	EC602	ControlSystem	3	0	0	3	3
4	PE	EC603	ProfessionalElective-III A:InformationTheory&Coding B: Renewable Energy Sources & Applications C:NanoTechnology D:RemoteSensing& GIS	3	0	0	3	3
5	OE	EC604	Open Elective-I A:ObjectOrientedProgrammingusingJAVA. B: Fundamentals of Sensors & Transducers C:IntroductiontoQuantumComputing D:FundamentalsofOperatingSystem	3	0	0	3	3
6	OE	EC605	Open Elective-II A:DatabaseManagementSystem	3	0	0	3	3

			B: 3D Printing and Design C: Web Intelligence & Big Data D: Scientific Computing					
B.PRACTICAL								
7	PC	EC691	VLSI & Microelectronics Lab	0	0	3	3	1.5
8	PC	EC692	Control System Lab	0	0	3	3	1.5
9	OE	EC694	Open Elective-I Lab A: Object Oriented Programming using JAVA Lab B: Fundamentals of Sensors & Transducers Lab C: Quantum Computing Lab D: Fundamentals of Operating System Lab	0	0	3	3	1.5
10	OE	EC695	Open Elective-III Lab A: Database Management System Lab B: 3D Printing and Design Lab C: Web Intelligence & Big Data Lab D: Scientific Computing Lab	0	0	3	3	1.5
11	PROJECT	PR691	Minor Project II	0	0	3	2	1
12	PROJECT	PR692	Skill Development VI: Soft Skill & Aptitude-III	0	0	1	1	0.5
C.MANDATORY ACTIVITIES/COURSES								
13	MC	MC601	Intellectual Property Right	2	0	0	2	0
TOTAL CREDIT WITHOUT MOOC COURSES								24.5
D.MOOC COURSES**								
14	MOOC COURSES	HM601	MOOC COURSE-V	3	1	0	4	4
TOTAL CREDIT WITH MOOC COURSES								28.5

****MOOC COURSES for HONOURS/MINOR Degree are Programs specific and to be taken from MOOCS BASKET**

Course Name: Economics for Engineers

Course Code: HSMC604

Contact: 2:0:0

Total Contact Hours: 24

Credits: 2

Prerequisites: NIL

Course Outcome:

Graduates of the ECE program will be able to:

- CO1:** To identify various uses for scarce resources
- CO2:** To understand key economic concepts and implement in real world problems
- CO3:** To apply critical thinking skills to analyze financial data and their impacts.
- CO4:** To evaluate business performance through cost accounting principles

Course contents:

Module-1. Introduction to Economics: [2L]

Meaning, Nature and Scope of Economics

Module- 2. Theory of Demand and Supply: [4L]

Concept of demand, Determinants of demand, Individual and Market Demand, Exception to the law of demand. Concept of Supply, Shift in Demand and Supply Curve, Movement along the demand and supply curve, Determinants of equilibrium price and quantity, Elasticity of Demand and Supply.

Module -3. Theory of Production and Costs: [6L]

concept of Production function, types of Production function, Laws of return to scale and variable Proportion, Cost Function, Types of Cost Function, Different Cost curves, Relation between Average and marginal cost, Relationship between

Short Run costs and Long Run costs, Profit maximization

Module-4.MacroeconomicAggregatesandConcepts: [3L]

GDP,GNP.ConceptsofNationalIncome.ConceptofBusinessCycle.

Module-5.Inflation [2L]

Concept,CausesandRemediesofInflation.

Module-6.Accounting: [4L]

BasicconceptofJournal,PreparationofIncomeStatement,andBalanceSheet.

Module–7.CostVolumeProfitAnalysis: [3L]

Contribution, P/V Ratio, Break-Even Point, Margin of Safety, Short term decision making: Makeor Buy, Shut-down point,ExportPricing, Opportunityand Sunk cost.

ReferenceBooks:

1. EconomicsbyLipseyandChrystal
2. ModernEconomicTheorybyK.K.Dewett.
3. PrincipleofEconomics byH.L.Ahuja
4. EngineeringEconomicsbyR.PaneerSeelvan:
5. ModernAccountancybyHanif&Mukherjee

CO-POmapping

COs	PO1	PO2	PO3	PO4	PO5	PO6	PO7	PO8	PO9	PO10	PO11	PO12	PSO 1	PSO 2	PSO 3
CO1	-	3	-	1	-	-	-	2	1	-	2	-		1	
CO2		-		-	-	-	3	-	-	-	2	-		1	
CO3	-	1	-	2	2	3	-	-	-	1	2	2		1	
CO4	1	-	-	3		-	-	2	-	-	3	2		1	
AVG	1	2		2	2	3	3	2	1	1	2.25	2		1	

Weightage Values:3=Stronglymatched,2=Moderatelymatched,1=Weaklymatched,(-)=
Notmatched.

Course Name: VLSI & Microelectronics

Course Code: EC601

Contact: 3:0:0

Total Contact Hours: 36

Credits: 3

Prerequisite: Basic concept of Electronic Devices, Analog & Digital Electronic Circuits

Course Outcomes

CO1: Able to illustrate scale of integration – SSI, MSI, LSI, VLSI, Moor's Law, scaling, short channel effect, VLSI design flow, FPGA architecture, classify Standard IC & ASIC, and construct gate level circuit with the help of PAL & PLA architecture.

CO2: Able to analyze CMOS inverter voltage transfer characteristics with the parameters – V_{IL} , V_{IH} , V_{OL} , V_{OH} , V_{th} and based on the knowledge of digital circuit design methodology like – CMOS, Pass transistor, TG, DCVSL, dynamic logic, NORA, able to construct schematic of simple and complex combinational circuit, sequential circuit (SR flip-flop, JK flip-flop, D flip flop), 6T - SRAM Cell, 3T- DRAM cell using MOSFET.

CO3: Able to estimate the value of resistance of current source/sink, MOS diode, current of current mirror circuit, voltage of reference circuits (voltage divider, threshold voltage references and band gap reference), value of parameters to design CMOS differential amplifier, resistance of switch capacitor circuit, gain of switch capacitor integrator and 1st order switch capacitor filter based on the concept of small signal model & switching characteristics of MOSFET.

CO4: Able to describe the fabrication steps of ICs and construct the stick diagram & layout of CMOS inverter & basic gates based on lambda and micron design rules.

CO5: Able to estimate the gate delay, dynamic power, short circuit power and leakage power and total power consumption across CMOS inverter circuit with the help of switching activity, saturation & linear region current equations of MOSFETs and principle of charging & discharging of capacitor.

CourseContent

Module1:IntroductiontoIC

[5L]

Integrated Circuits – Advantages, disadvantages, limitations; Scale of Integration – SSI, MSI, LSI, VLSI, ULSI; Moor's Law; Scaling of MOSFET-Constant field scaling and constant voltage scaling, Short Channel Effects; VLSI design flow, Y- Chart, IC Classification –Standard IC and ASIC, PAL, PLA, FPGA Architecture.

Module2: DigitalVLSICircuitDesign[11L]Inverter Characteristics [2L]

Resistive load inverter – Voltage transfer characteristics (VTC, significance of parameters (only expression, no derivation) –VIL, VIH, VOL, VOH, Vth; CMOS inverter - VTC, Noise margin and aspect ratio of symmetric CMOS inverter.

CombinationalLogicCircuitDesign

[6L]

Circuit design using Static CMOS style – basic gates, design of circuit for product of sum (POS) and sum of product (SOP) expression, Complex logic circuit, full adder; Circuit design using pseudo NMOS logic, DCVSL Logic, TG Logic, Pass Transistor Logic, Complementary pass transistor logic, Dynamic logic, domino logic, NORA logic.

Sequential Circuit and Semiconductor Memory Design

[3L]

Bistable Circuit -Design of CMOS S-R & J-K Latch, CMOS Clocked SR & JK Latch /Master –slave JK Flip-flop, CMOS D Flip-flop; 6T SRAM cell and 3T DRAM cell design.

Module 3: Analog VLSI Circuit Design

[9L]

Small Signal model of MOSFET; Analog sub-circuits -MOS Switch, Active resistors/MOS Diode , Current source and Sink ,Current Mirror ; Current and voltage references-voltage divider , MOS equivalent of P-N junction Voltage reference , Threshold voltage reference , Band gap reference (Basic Principle) ; Switch-Capacitor Circuit – resistance emulation of series , parallel and series-parallel circuit , Switch capacitor integrator and filter (1st order only) ;CMOS differential amplifier – design parameters ;Output amplifier (basic circuit) ; Block diagram of two-stage CMOS OP-AMP (description only)

Module4:LayoutDesignRules andFabricationStepsofICs

[6L]

Micron and lambda design rules; Stick diagram and Layout - CMOS Inverter, NAND and NOR gate; Fabrications steps of IC – Wafer preparation, Oxidation, photolithography, etching, diffusion, ion-implantation, metallization, and packaging. CMOS N-Well Process, overview of P-well and twin-tub

process.

Module 5: Introduction to Low Power and High-Speed VLSI Circuit Design[5L]

Dynamic power, short circuit power and leakage power in CMOS Inverter; Switching activity & Logical effort of basic gates; Timing parameters (concept only) –Critical path, arrival time, slack, skew, set-up time, hold time, gate delay and path delay, delay time expression of CMOS inverter (expression only), Adiabatic logic (basic concept)

Text Books:

1. Digital Integrated Circuit , J.M.Rabaey, Chandrakasan, Nicolic, Pearson Education.
2. CMOS Digital Integrated Circuits Analysis and Design , S.M.Kang & Y.Leblebici, TMH.
3. CMOS Analog Circuit Design , Allen & Holberg , Oxford
4. Design of Analog CMOS Integrated Circuits, Behzad Razavi , TMH .

Reference Books:

1. Microelectronic Circuits, Sedra & Smith, Oxford
2. Introduction to VLSI Circuits and System, Uyemura , Wiley
3. VLSI Design, Debaprasad Das, Oxford
4. VLSI Design and EDA Tools , Angsuman Sarkar , Swapnadip De , C.K. Sarkar , Scitech
5. VLSI Design Techniques for Analog and Digital Circuits , Geiger , Allen , Strader , TMH

CO-POmapping:

	PO1	PO2	PO3	PO4	PO5	PO6	PO7	PO8	PO9	PO10	PO11	PO12	PSO1	PSO2	PSO3
CO1	2	2	3	1	1	-	1	1	2	1	1	1	3	2	
CO2	3	3	3	3	1	2	-	1	2	1		3	3	3	
CO3	3	3	3	2	1	-	2	1	2	1		3		2	
CO4	3	3		1	1	-	-	1	2	1		3		2	
CO5	3	3		1	1	2	2	1	2	1		3		2	
AVG	2.8	2.8	3	1.6	1	2	1.7	1	2	1	1	2.6	3	2.2	

CourseName: ControlSystems

Course Code: EC602

Contact: 3:0:0

Total Contact Hours: 36

Credits:3

Pre requisite: Concepts in electrical circuits (Studied in Basic Electrical), Fundamental concepts on Laplace Transformation (studied in Mathematics)

CourseOutcome:

After completing the course the student will be able to:

CO1: Apply modelling techniques to represent physical systems and distinguish between open loop and closed loop control systems.

CO2: Determine the time responses of different type of systems and compute time domain specifications.

CO3: Analyze the stability of control systems using root-locus.

CO4: Examine the relative stability of control systems using frequency domain analysis

.CO5: Design controllers according to desired performance specifications.

Module I INTRODUCTION TO CONTROL SYSTEMS & MODELLING [7L]

Basic Elements of Control System, Linear, Non-Linear and Discrete Time System (Introduction & Concept)
) Open loop and Closed loop systems – Differential equation on control system – About transfer function and its generation technique, Modelling of Electrical and mechanical systems - Block diagram reduction techniques - Signal flow graph, Mason's gain formula.

Module II TIME RESPONSE ANALYSIS [5L]

Time response analysis – Different input deterministic test response – Order and Type of the systems incorporation with time response - First Order Systems - Impulse and Step Response analysis

of second order systems - Steady state errors and error constants.

Module III STABILITY ANALYSIS

[6L]

Routh -Hurwitz Criterion, Root Locus Algorithm, Construction of Root Locus, Effect of addition of pole and zero on the root locus, Application of Root Locus Diagram.

Module IV FREQUENCY RESPONSE ANALYSIS

[6L]

Concept of Frequency Response of a system, Bode Plot Computational Algorithm, Construction of Bode diagram, Polar Plot, Phase and gain margin Nyquist Plot, Interpretation of Bode and Nyquist plot, Stability analysis using frequency domain specifications. Correlation between time & frequency response in control system.

Module V CLASSICAL CONTROL DESIGN TECHNIQUES

[4L]

Introduction to PI, PD and PID Controllers, Tuning of PID controller using Ziegler-Nichols methods, Introduction to lead, lag and lead-lag compensator.

Module VI STATE SPACE ANALYSIS OF CONTINUOUS TIME SYSTEMS

[6L]

Concepts of state, state variables and state model, derivation of state models from block diagrams, Diagonalization - Solving the Time invariant state Equations - State Transition Matrix and its Properties - Concepts of Controllability and Observability. Concept of state feedback.

Module VII ADVANCED CONTROL SYSTEM AND ITS APPLICATION

[2L]

Concept of Robust Control, Adaptive Control and Model Predictive Control. Application of advanced control system (Robotics, Traffic system and radar tracking) in different fields.

Text Books:

1. Automatic Control Systems 8th edition - by B.C. Kuo 2003 - John Wiley and son's,
2. Control Systems Engineering - by I.J. Nagrath and M. Gopal, New Age International (P) Limited, Publishers, 2nd edition.
3. Control Systems - by Ramesh Babu

ReferenceBooks:

1. Modern Control Engineering – by Katsuhiko Ogata – Prentice Hall of India Pvt. Ltd., 3rd edition, 1998.

CO-POmapping:

	PO1	PO2	PO3	PO4	PO5	PO6	PO7	PO8	PO9	PO10	PO11	PO12	PSO1	PSO2	PSO3
CO1	3	3	2						1	1		1	3	2	
CO2	3	2	2						2	1		1	3	2	
CO3	3	2	1	2					2	1			3	2	
CO4	3	1							2	1		1	3	2	
CO5	1	1	3	2					2	1		1	3	1	
AVG	2.6	1.8	2	2					1.8	1		1	3	1.8	

CourseName:Information Theory&Coding

Course Code: EC603A

Contact:3:0:0

Total Contact Hours: 36

Credits: 3

Prerequisite:DigitalEelctronics,probability

CourseOutcomes:

CO1:Understandthe conceptsofinformation,mutualinformationandentropyandvarioussourcecodingtechniques.

CO2:Analysetheneedforerrorcontroltechniquesinadigitalcommunicationsystemchannelmodels,channelcapacity andchannelcoding techniques.

CO3:Applylinearalgebra,conceptofGaloisfield,conjugateroots,minimalpolynomialinchannelcodingtechniques forerrorcontrol.

CO4:Generatedifferenterrorcontrolcodeslikelinearblockcodes,cycliccodes,BCHcodes,andperformerror detection and correction.

CO5:Designthecircuitfor differenterrorcontrolcodingtechniques.

CourseContent

Module1:Source Coding

[6L]

Uncertaintyandinformation,averagemutualinformationandentropy,informationmeasuresforcontinuou
srandomvariables,sourcecodingtheorem,Huffmancodes.Shannon-FanoCoding.

Module2: Channel CapacityandCoding

[4L]

Channelmodels,channelcapacity,channelcoding,informationcapacitytheorem,TheShannonlimit.

Module3:LinearandBlockCodesforErrorCorrection

[6L]

Matrixdescriptionoflinearblockcodes,equivalentcodes,paritycheckmatrix,decodingofalinearblock,Standardarrayandsyndromedetectioncode,perfectcodes,Hammingcodes.

Module4:CyclicCodes

[6L]

Polynomials,divisionalgorithmforpolynomials,amethodforgeneratingcycliccodes,matrixdescriptionofcycliccodes,decodingcycliccodes,EncodingandDecodingcircuit

Module5:BCH Codes

[6L]

Set,group,fields,GaloisfieldPrimitiveelements,minimalpolynomials,generatorpolynomialsinterms ofminimalpolynomials, examples of BCHcodes.

Module6: OtherCodes:

[8L]

ConvolutionalCodes:Encoding,statediagram,

Tree codes, trellis codes, polynomial description of convolutional codes, distance notions forconvolutionalcodes,thegeneratingfunction,matrixrepresentationofconvolutionalcodes,decodingofconvolutionalcodes,Viterbidecoding,examplesofconvolutionalcodes,Turbocodes,Turbodecoding.

ApplicationofInformationTheoryandCodinginCyberSecurity,SignalProcessingApplicationofInformationTheoryandCodingin MachineLearning

TextBooks:

- 1.Information theory, coding and cryptography - Ranjan Bose; TMH.2.IntroductiontoErrorControlCodes - Salvatore Gravano,Oxford
- 3.Information theory, coding andcryptography–A Saha, SMondal;Pearson

ReferenceBooks:

- 1.Information and Coding - N Abramson; McGraw Hill.2.Introduction to Information Theory - M Mansurpur; McGraw Hill.3.InformationTheory-RBAsh;PrenticeHall.

4. ErrorControlCoding - ShuLinandDJCostelloJr;PrenticeHall.
5. ToddKMoon,-ErrorCorrectionCoding:MathematicalMethodsandAlgorithms,JohnWiley&Sons

CO-POMapping:

	PO1	PO2	PO3	PO4	PO5	PO6	PO7	PO8	PO9	PO10	PO11	PO12	PSO1	PSO2	PSO3
CO1	3	3	3	1	3	1	1	1	1	1	1	3	3	2	2
CO2	3	3	3	1	3	1	1	1	1	1	1	3	3	2	2
CO3	3	3	3	3	3	2	2	1	1	1	2	3	3	2	2
CO4	3	3	3	3	3	2	2	1	1	2	1	3	3	2	1
CO5	3	3	3	3	3	1	2	1	2	2	2	3	3	1	1
AVG	3	3	3	2.2	3	1.4	1.6	1	1.2	1.4	1.4	3	3	1.8	1.6

CourseName:RenewableEnergySources&Applications

CourseCode:EC603B

Contact:3:0:0

Total Contact Hours:36

Credit:3

Prerequisite:Renewable EnergySources&Applications

CourseOutcomes:

CO1:ExplaintheimportanceofRenewableenergyoverconventionalprocess

CO2: Describe different methods of Power generation from the Non- conventional sources likeSolar, Wind Energy, Biomass, Geothermal energy, OTEC, Tidal energy, MHD Power generationschemes.

CO3:Analyzehedifferenttechniques ofgridintegrationofthepowergeneratedfromrenewableenergysourceswiththeinitiationof powerelectronicconvertersanddrives.

CO4:Designdifferenthybridenergysystems andenergystoragesystems.

CourseContent

Module1: [2L]

Renewable and non-renewable energy sources, energy consumption as a measure of Nation'sdevelopment&economic growth; strategy formeeting the futureenergy requirementsGlobaland National scenarios, Prospects of renewable energy sources. Impact of renewable energygenerationon environment, KyotoProtocol.

Module2: [9L]

SOLAR ENERGY: Solar radiation - beam and diffuse radiation, solar constant, earth sun angles,attenuation and measurement of solar radiation, local solar time, derived solar angles, sunrise,sunsetand day length.

SOLAR THERMAL COLLECTORS & HEATING: Flat plate collectors, Concentrating collectors, Solar air heaters-types, storage of solar energy-thermal storage, solar water heaters,solar distillation, solar cooker, solar heating & cooling of buildings.

SOLAR PHOTOVOLTAIC SYSTEMS: Theory of solar cells, different types of PV Cells, Mono-poly Crystalline and amorphous Silicon solar cells. Concept of module, array. Classification of PV systems, Advantages and disadvantages. Efficiency and cost of PV systems & its applications.

Module 3: [5L]

Principle of wind energy conversion; Basic components of wind energy conversion systems; wind mill components, various types and their constructional features; design considerations of horizontal and vertical axis wind machines: analysis of aerodynamic forces acting on wind mill blades and estimation of power output from wind turbine; wind data and importance of site selection, characteristics of different types of wind, generators used with wind turbines. Merits & demerits.

Module 4: [2L]

HYDEL ENERGY

Electricity generation from micro hydro plants, location, auxiliaries and associated problems. Advantages & disadvantages.

Module 5: [6L]

BIOMASS ENERGY

Characteristics and Properties of Biomass, Structural components of Biomass, Biomass conversion technologies - Biomass conversion routes, Biochemical and Thermo-chemical routes, Industrial Biogas generation plants - Transformation of Biomass to Biogas, classification, advantages and disadvantages, constructional details, site selection, digester design consideration, filling a digester for starting, maintaining biogas production, Fuel properties of biogas, utilization of biogas, Biodiesel.

Module6:**[2L]****GEOHERMALENERGY**

Estimation and nature of geothermal energy, geothermal sources and resources like hydrothermal, geopressured hot dry rock, magma. Advantages, disadvantages and application of geothermal energy, prospects of geothermal energy in India.

Module7:**[2L]****ENERGY FROM OCEAN**

Ocean Thermal Electric Conversion (OTEC) systems like open cycle, closed cycle, Hybrid cycle, prospects of OTEC in India. Ocean Energy from tides, basic principle of tidal power, single basin and double basin tidal power plants, advantages, limitation and scope of tidal energy. Wave energy and power from wave, wave energy conversion devices, advantages and disadvantages of wave energy.

Module8: MAGNETO HYDRO DYNAMIC POWER GENERATION:**[2L]**

Principle of MHD power generation, Classification of MHD system, Design problems and developments, gap conductivity, materials for MHD generators and future prospects.

Module9: HYDROGEN ENERGY:**[2L]**

Introduction, Hydrogen Production methods, Hydrogen storage, hydrogen transportation, utilization of hydrogen gas, hydrogen as an alternative fuel for vehicles.

Module10: FUEL CELL:**[2L]**

Introduction, principle of operation of fuel cell. Types of fuel cells, efficiency of fuel cell, application of fuel cells, limitations.

Module11:HYBRID SYSTEMS:**[2L]**

Introductiontohybridsystems,NeedforHybridSystems,DifferenttypeofHybridsystemslikeDiesel-PV, Wind-PV, Microhydel-PV, Biomass-Dieselsystems.

TextBooks:

1. NonConventionalEnergyResources,ShobhNathSingh,PEARSON.
2. NonConventionalEnergyResourcesbySHasanSaeed,DKSharma,S.k.Kataria&Sons
3. NONCONVENTIONALRESOURCESOFENERGY,G.S.SAWHNEY,EasternEconomyEdition
4. NonConventionalEnergyResources,B.HKhan,McGrawHill Education(Chennai)

ReferenceBooks:

1. NonConventionalEnergyResources,N.K.Bansal,Vikas.
2. NonConventional EnergyResourcesAndUtilisation.ErR.KRajput,SChandPublishers.
3. RaiG.D.,“Non–ConventionalEnergySources”,KhannaPublishers, 1993.
4. RaiG.D.,“SolarEnergyUtilisation”,KhannaPublishers, 1993.

CO-POMapping:

COs	PO1	PO2	PO3	PO4	PO5	PO6	PO7	PO8	PO9	PO10	PO11	PO12	PSO1	PSO2	PSO3
CO1	3	3	1	1	-	2	-		2	2	2	3	3	2	
CO2	3	2	2	1	2	3	-		2	1	2	3	3	2	
CO3	3	2	1	3	-	3	1		1	1	1	3	3	2	
CO4	2	2	1	1	-	3	1		1	1	1	3	3	2	
AVG	2.8	2.3	1.3	1.5	2	2.8	1		1.5	1.3	1.5	3	3	2	

CourseName:NanoElectronics

CourseCode:EC603C

Contact:3:0:0

Total Contact Hours:36

Credit:3

CourseOutcome:

After successful completion of this course, students should be able to:

CO1: Explain the fundamental science and quantum mechanics.

CO2: comprehend the basics of nano-electronics and the phenomena involved in the operation of nano-devices.

CO3: explain the fabrication details and analytical techniques of nanomaterials.

CO4: realize the advantages of the nano-materials and its appropriate use in solving practical problems.

Prerequisite:

The candidates should have the basic knowledge of materials physics and charge transport phenomena in electronic devices.

CourseContent:

Module I: Introduction and Background

[8L]

Introduction to nano-electronics, Limitations of conventional microelectronics, Trends in microelectronics and optoelectronics. Mesoscopic physics, characteristic lengths in mesoscopic systems. Basics of Quantum Mechanics: Schrodinger equation, Density of States. Particle in a box concepts, Degeneracy. Band theory of solids, Kronig-Penney Model, Brillouin zones, Quantum mechanical coherence

Module II: Fabrication

[10L]

Introduction to methods for fabrication of nano-layers, different approaches, physical vapour deposition, chemical vapour deposition. Molecular Beam Epitaxy, Ion Implantation, Formation of Silicon Dioxide- dry and wet oxidation methods. Fabrication of nanoparticles- grinding with iron balls, laser ablation, reduction methods, sol-gel, self-assembly, precipitation of quantum dots. MEMS/NEMS design, processing, Oxidation, Sputter deposition, Evaporation, Chemical vapor deposition etc.

Module III : Nano Devices

[10L]

Classification of Nanostructures, Low dimensional structures: Quantum wells, wires and dots, Density of states and dimensionality. Basic properties of two dimensional semiconductor nanostructures, carbon nanotube and graphene

Introduction to scaling – Scaling of physical systems – Geometric scaling & Electrical system scaling, The Single-Electron Transistor: Single-Electron Transistor Logic, Other SET and FET Structures, Carbon Nanotube Transistors (FETs and SETs), Semiconductor Nanowire FETs and SETs, Coulomb Blockade in a Nanocapacitor, Hot electrotransistors, Molecular SETs and Molecular Electronics. Resonant Tunneling Diode, Coulomb dots, Quantum blockade

Module IV: Characterization

[8L]

Introduction to characterization, characterization tools used for nanomaterials, Microscope and its types- optical and electron microscope. Principle of operation of Scanning Tunneling Microscope, Atomic Force Microscope, Scanning Electron microscope, Specimen interaction. Transmission Electron Microscope, X-Ray Diffraction analysis, UV-Vis spectroscopy, Particle size analyzer

Text Books

1. David J. Griffiths, Introduction to Quantum Mechanics, Cambridge India
2. V.V. Mitin, V.A. Kochelap & M. Strosio, Introduction to Nanoelectronics, Cambridge India
2. K.K. Chattopadhyay, Introduction to Nanoscience and Nanotechnology, PHI

3. S.Krishnamoorthy,Nanomaterials:A GuidetoFabricationandApplications,CRCPress

ReferenceBooks

1. NanoTechnologyandNanoElectronics–
Materials,devicesandmeasurementTechniquesbyWRFahrner– Springer
2. Nano:The Essentials–UnderstandingNanoScienceandNanotechnology
byT.Pradeep,TataMcGraw Hill.
3. IntroductiontoNano–BasicstoNanoscienceandNanotechnologybySengupta&Sarkar–Springer

CO-POMapping:

CO	PO1	PO2	PO3	PO4	PO5	PO6	PO7	PO8	PO9	PO10	PO11	PO12	PSO1	PSO2	PSO3
CO1	3	1	1	2	1	1	-	-	-	1	2	1	2	2	2
CO2	3	2	2	1	1	-	2	1	1	1	1	2	3	2	1
CO3	2	3	1	2	1	1	1	2	-	-	1	1	2	2	2
CO2	3	2	2	1	1	-	2	1	1	1	1	2	3	2	1
AVG	2.8	2	1.5	1.5	1	1	1.7	1.3	1	1	1.3	1.5	2.5	2	1.5

Course Name: Remote Sensing & GIS

Course Code: EC603D

Contact: 3:0:0

Total Contact Hours: 36

Credits:3

Pre-Requisite: Analog & Digital Communication, EM Theory & Antenna

Course Outcomes:

At the end of this course, students will be able to

CO1: Interpret the basic concept of remote sensing and GIS.

CO2: Recognize the principles of aerial and satellite remote sensing.

CO3: Describe different types of sensors in remote sensing and data representation in GIS.

CO4: Explain the about the different kinds of radar for atmospheric remote sensing.

CO5: Apply knowledge of GIS software and able to work with GIS software in various application fields.

CO6: Apply basic procedures of digital image processing for RS image enhancement analysis.

Course Content:

Module I: Introduction [2L]

Concept of Remote Sensing: Remote Sensing, Data, Sources of Energy, Interaction with Atmosphere and Target, Recording of Energy, Concept of GIS, types of GIS data: Civilian & Military, commercial GIS softwares

Module II: Radio Wave Propagation [10L]

Basic Radiopropagation mechanism: Short distance & long distance propagation cases. Free space Propagation models. Diffraction, Reflection and Scattering. Variation of the earth's reflectivity with angle of incidence, wavelength and geographical location; Seasonal variation of reflectivity; Effects of Solar radiation, Earth's thermal radiation, atmospheric radiation, cosmic background noise & atmospheric variation.

Module III: Remote Sensing

[12L]

Sensors and Cameras: optical and infrared detectors and filters, optical and infrared cameras; microwave and millimeter wave radiometers; scanning systems, mechanical and electronics systems; scatterometer; altimeter. Radar Imaging GPS: Calibration, Requirement of Ground Truth Data, Parameters of Ground Truthing Atmospheric Condition, Surface Water, Factors of Special Measurement—Sun Angle, Aerosol, Haze, Water Vapor. Remote Sensing of Atmosphere and Sea State: Passive and active remote sensing; Side Looking Airborne Radar (SLAR); Synthetic Aperture Radar (SAR); Along Track Scanning Radiometer (ATSR), Laboratory measurements of remote sensing parameters.

Module IV: Geographic Interpretation System

[12L]

Interpretation of Sensing Data: Photo-interpretation, image and pattern recognition; Spectral interpretation of remote sensing imagery; Interpretation of thermal maps; Color coding and enhancement; Computer interpretation of images. Tropical rainfall measurements; Microwave sensing of sea surface. GIS Software features, user-based updation of information system

Text Books:

1. R.P. Gupta, "Remote Sensing Geology", 2nd Edition. 2003, Springer
2. J.R. Jensen, 2014, "Remote Sensing of the Environment: An Earth Resource Perspective", 2nd Edition. 2014, Pearson Education Limited.
3. Anji Reddy, M., "Geoinformatics for Environmental Management", 2004. B.S. Publications.

Reference Books:

1. N.A. Armand, V.M. Polyakov, "Radio Propagation and Remote Sensing of the Environment", 2005. CRC Press.
2. Joseph George, 2003: Fundamentals of Remote Sensing. Universities Press.
3. Satellite Communication, D.C. Agarwal, and Khanna publisher.

CO-PO-PSO MAPPING:

	PO1	PO2	PO3	PO4	PO5	PO6	PO7	PO8	PO9	PO10	PO11	PO12	PSO1	PSO2	PSO3
CO1			2						3		3		2	2	2
CO2				2		2		3	3	1	3	3	2	3	1
CO3	3		2						2		3	3	2	2	2
CO4						2			3	1	3		2	2	2
CO5		2		2				2	3		3		1	2	1
CO6	3					3				2			2	2	2
AVG	3	2	2	2		2.3		2.5	2.8	1.3	3	3	1.8	2.2	1.7

Course Name: OBJECT ORIENTED PROGRAMMING USING JAVA

Course Code: EC604A

Contact: 3:0:0

Total Contact Hours: 36

Credits: 3

Prerequisite:

Basicknowledgeofcomputers,basicknowledgeofprogramming.

CourseOutcomes:

AftersuccessfullycompletingthecoursetheUndergraduatestudents willbeableto:

CO1: Understand the key concepts of object-oriented programming and have an ability to designObjectOrientedprogramsandappreciatethetechniquesofgooddesign.

CO2:UnderstandadvancedfeaturesofJava.

CO3:Analyzecomplexprogrammingproblemsandoptimizethesolutions.

CO4:ApplyanunderstandingofethicalprinciplestoproblemswhichcommonlyariseintheInformationTechnologyIndustry.

CourseContent:

MODULEI:Objectoriented design [2L]

Conceptsofobject-orientedprogramminglanguage,Object,Class,relationshipsamongobjects,aggregation,links,relationshipsamongclasses-association,aggregation.

MODULEII:Objectorientedconcepts [2L]

Class,object,messagepassing,inheritance,encapsulation,polymorphism,DifferencebetweenOOPandotherconventionalprogramming–advantagesanddisadvantages.

MODULEIII: Understanding Javaprogramming language [2L]

History of Java Programming languages, Purpose of invention of Java. Structure of a basic JavaProgram,

Component of Java Development Kit-API, JRE, Understanding the steps to run a completeJavaProgram.

MODULEIV:Basic ComponentsofJavaProgram [2L]

JavaTokens-Literals, identifier, keywords, operator, separator, Data types, variables, constant, Typecasting-defining type casting, requirement of type casting, implicit and explicit type casting. Controlstructure.Accessspecifier.

MODULEV:Class &Objectproprieties [6L]

Defining class and object, Class Members-Local variable, instance variable, class variable, Primitive andReferencevariable,Constructor,thiskeyword,finalize andgarbage collection,Array-Declaringanddefining array, accessing array elements, length properties, 2D array, anonymous array, array of Objects.Understandingmethod-methodreturningobject,passingobjects,methodpassingandreturningarrays,

use of method overloading. Static-Static block and non static block, static variable, static method. nested&innerclasses.

MODULEVI:Reusabilityproperties [6L]

Super class & subclasses including multilevel hierarchy, process of constructor calling in inheritance, useof super and final keywords with super() method, dynamic method dispatch, use of abstract classes &methods,interfaces.Creationof packages, importingpackages,member accessfor packages.

MODULEVII: String Handling [3L]

Basicstringhandlingconcepts- String (discusscharAt(), compareTo(),equals(), equalsIgnoreCase(),indexOf(),length(),substring(),toCharArray(),toLowerCase(),toString(),toUpperCase(),trim(),valueOf()methods)&StringBufferclasses(discussappend(),capacity(),charAt(),delete(),deleteCharAt(),ensureCapacity(),getChars(),indexOf(),insert(),length(),setCharAt(),setLength(),substring(),toString() methods),conceptofmutableandimmutable string,commandline arguments.

MODULEVIII:Exceptionhandling&Multithreading [5L]

Exception handling basics, different types of exception classes, use of try & catch with throw, throws &finally, creation of user defined exception classes. Basics of multithreading, main thread, thread life cycle,creationofmultiplethreads,threadpriorities,threadsynchronization,inter-threadcommunication,deadlocksforthreads, suspending &resuming threads.

MODULEIX:BasicIOOperationandFileHandling [2L]

UnderstandingunformattedandformattedIO.Readingandwritingfiles.

MODULEX: Swing Programming**[3L]**

Swing Origins, Components and containers, Difference between AWT and swing, small swing programs, swing apps, concept of delegation event model and listener.

MODULEXI: Applet Programming (using swing)**[3L]**

Basics of applet programming, applet life cycle, difference between application & applet programming, parameter passing in applets, concept of delegation event model and listener, I/O in applets.

Text Books:

1. Rambaugh, James Michael, Blaha – "Object Oriented Modelling and Design" – Prentice Hall, India
2. Ali Bahrami – "Object Oriented System Development" – McGraw Hill
3. Patrick Naughton, Herbert Schildt – "The complete reference - Java 2" – TMH

Reference Books:

4. R.K Das – "Core Java For Beginners" – VIKAS PUBLISHING
5. Deitel and Deitel – "Java How to Program" – 6th Ed. – Pearson
6. Ivor Horton's Beginning Java 2 SDK – Wrox
7. E. Balagurusamy – "Programming With Java: A Primer" – 3rd Ed. – TMH

CO-PO Mapping:

	PO1	PO2	PO3	PO4	PO5	PO6	PO7	PO8	PO9	PO10	PO11	PO12	PSO1	PSO2	PSO3
CO1	3	3	3	3	2	-	-	-	3	-	-	3	3	2	2
CO2	3	3	3	3	2	2	-	-	3	-	2	3	3	2	2
CO3	3	3	3	3	2	-	-	-	3	2	-	3	3	2	2
CO4	3	3	3	3	2	-	-	-	3	-	-	3	3	2	1
CO5	2	3	3	3	2	-	-	-	3	-	-	3	3	1	1
AVG	2.8	3	3	3	2	2	-	-	3	2	2	3	3	1.8	1.6

Course Name: Fundamentals of Sensor and Transducers

Course Code: EC604B

Contact: 3:0:0

Total Contact Hours: 36

Credits:3

Prerequisite:

Students should have basic knowledge of Basic Electrical and Electronics as they are enabled to design different instruments as per their requirements in Industrial purpose.

Course Outcome:

After successfully completing this course, the student will be able to:

CO1. Familiar with the basics of measurement system and its input, output configuration of measurement system

CO2. Familiar with both static and dynamic characteristics of measurement system

CO3. Familiar with the principle and working of various sensors and transducers

CO4. Able to design signal conditioning circuit for various transducers

CO5. Able to identify or choose a transducer for a specific measurement application

Course contents:

Module I

Introduction & Characteristics of Transducers

[4L]

Introduction to sensors and transducers, Measurement system, Principles of sensing & transduction, Classification of sensors, Static characteristics and Dynamic characteristics: Zero, first order and second order measurement system, Response to impulse, step, ramp and sinusoidal inputs, sensitivity calculation, error estimation, Types of errors, Limiting error with examples, Principle of sensing & transduction, transducer classification, emerging fields

of sensor technologies

Resistive Sensing Element [3L]

Potentiometer: Loading effect, Strain gauge: theory, types, temperature compensation, applications: force, velocity and torque measurements.

Inductive Sensing Element [3L]

Self-inductive transducer, Mutual inductive transducers, Variable Reluctance type, Linear Variable Differential Transformer (LVDT): construction, Characteristic Curve, application: LVDT Accelerometer, LVDT displacement sensors.

Module II

Capacitive Sensing Element [3L]

Capacitive transducer: Variable Area Type, Variable distance type, Variable Permittivity type, calculation of sensitivities, applications.

Piezoelectric & Piezoresistive Sensing Element [5L]

Piezoelectric effects, charge and voltage coefficients, crystal model, materials, natural and synthetic types – their comparison, force and stress sensing, piezoelectric accelerometer, piezoresistive sensor.

Tachometers [2L]

Stroboscopes, Encoders, seismic accelerometer, Measurement of vibration, Proximity switches, Load cells: pneumatic, piezoelectric, elastic and magneto-elastic types – their mounting.

Module III

Optical Sensors [3L]

Light Dependent Resistor, Photodiode, Phototransistor, Photomultiplier tube, Optocoupler, solar cell

Magnetic Sensors [4L]

Sensors based on Villari effect for assessment of force, torque, rpm meters, Hall Effect and Hall drive, and performance characteristics, Magnetostrictive transducers, Seismic instrument

Radioactive sensors [3L]

Gieger counter, proportional counter, Scintillation detection, Ionization chamber.

Module IV

Course Name: Introduction to Quantum Computing

Course Code: EC604C

Contact: 3:0:0

Total Contact Hours: 36

Credits: 3

Prerequisite: Data Structure and Algorithm, Programming in Python/C#

Linear Algebra (Matrix and Determinant), Fourier Transform, quantum physics and mechanics

Course Outcomes: After this course students will be able to

CO1: Develop quantum logic gate and circuits

CO2: Explain the working of a Quantum Computing program, its architecture and program model

CO3: Design error correction circuits using quantum gates

CO4: Develop quantum algorithm program on major toolkits

CO5: Conceptualize the basic models of quantum cellular automata and partitioned quantum cellular automata.

Course Content

Module 1: Motivation for studying Quantum Computing:

8L

Major players in the industry (IBM, Microsoft, Rigetti, D-Wave etc.), Origin of Quantum Computing, Overview of major concepts in Quantum Computing, Qubits and multi-qubits states, Bra-ket notation. Quantum Superposition, Quantum Entanglement, quantum mechanics of qubits, quantum states, superposition.

Mathematical Foundation for Quantum Computing: Matrix Algebra: basis vectors and orthogonality, inner product and Hilbert spaces, matrices and tensors, unitary operators and projectors, Dirac notation, Eigenvalues and Eigenvectors. tensor product;

Module2:Introduction toreversiblelogicand quantumgates:

10L

Basic definition, Toffoli gate, Peres gate, Double Peres gate, Fredkin gate, Swap gate; simpleAND,OR,NOR,NAND,gatedesignusingreversiblelogic;IntroductiontoRCViewersimulator; Half and Full adder/ subtractor using reversible logic; Implementation of NOT gateusingV and V+gate, reversiblecircuitimplementationand matrixrepresentation.

Quantum NOT gate and its matrix model, CNOT gate (Feynman gate), Pauli matrices, ConjugateTransposematrixrepresentationandits conditions,X,Y,Z,Phasegate,Hadamardgate

Unitary and Identity gates; implementation of CNOT, Toffoli, Peres and Double Peres gatesusing CV and CV+ gates; Decomposition of OR gate, adders and subtractors into quantum gatesandsimulationusingRCViewer/RCViewerplus.

Module3:BuildingBlocks forQuantumProgram

8L

ArchitectureofaQuantumComputingplatform,Details ofq-bitssystemofinformationrepresentation:

- BlockSphere
- Multi-qubitsStates
- validand invalidsuperposition
- QuantumEntanglement
- Usefulstatesfromquantumalgorithmicperceptiv.e.g.BellState
- Operationonqubits:Measuringandtransformingusinggates.
- QuantumLogicgatesandCircuit:Pauli,Hadamard,phaseshift,controlledgates,Ising, Deutsch, swap etc.

ProgrammingmodelforaQuantumComputingProgram

- Stepsperformedonclassicalcomputer
- StepsperformedonQuantumComputer
- Movingdatabetweenbitsandqubits.

Quantumprogramminglanguages,introductiontoquantumcryptographyandquantuminformationtheory.

Module4:Quantumtransformation,searching,Quantumerrorcorrection:

4L

quantumFouriertransformandquantumsearchalgorithm,phaseestimation,entanglement,teleportation,3 qubit system forerrorcorrection,Shorcode,degenerate codes,generatorandparitycheckmatrices,entropy(selfandmutual),VonNeumannentropy

Module5:BasicsofQuantumComputerandQuantumAlgorithms:

6L

Basistechniquesexploitedby quantumalgorithms.

- Amplitudeamplification
- Quantum WalksMajorAlgorithms
- Shor'sAlgorithm
- Grover'sAlgorithm
- Deutsch'sAlgorithm
- Deutsch-JozsaAlgorithm

OSSToolkitsforimplementingQuantumprogram

- IBM quantumexperience
- MicrosoftQ

TextBooks:

1. "QuantumComputationandQuantumInformation",MichaelA.Nielsen&IsaacL.Chuang,CambridgeUniversity Press
2. Quantumcomputingforcomputerscientists,NosonS. Yanofsky,MircoA.Mannucci,CambridgeUniversity Press2008

References:

1. Quantumcomputingexplained,DavidMcMahon,Wiley-interscience,JohnWiley&Sons,Inc.Publication2008
2. RileyTiptonPerry,"QuantumComputingfromtheGroundUp",WorldScientificPublishing Ltd(2012).
3. P.Kok,B.Lovett,"IntroductiontoOpticalQuantumInformationProcessing",Cambridge(2010).

4. Scott Aaronson, "Quantum Computing since Democritus", Cambridge (2013).
5. Introduction to Quantum Mechanics, 2nd Edition, David J. Griffiths, Prentice Hall New Jersey 1995
6. Onlinemath tutorial: <http://patrickjmt.com/>
7. <https://www.coursera.org/learn/quantum-computing-algorithms>
8. IBM Experience: <https://quantumexperience.ng.bluemix.net>
9. Microsoft Quantum Development Kit <https://www.microsoft.com/en-us/quantum/development-kit>
10. Forest SDK PyQuil: <https://pyquil.readthedocs.io/en/stable/>

CO-PO Mapping:

CO	PO1	PO2	PO3	PO4	PO5	PO6	PO7	PO8	PO9	PO10	PO11	PO12	PSO1	PSO2	PSO3
CO1	3	-	2	-	-	-	-	-	-	-	-	-	-	--	1
CO2	-	-	3	2	-	-	-	-	-	-	-	-	-	-	-
CO3	-	2	-	3	1	-	-	-	-	-	-	-	-	-	-
CO4	2	1	3	-	2	1	-	-	-	-	-	-	-	-	--
CO5	3	-	2	3	-	2	3	-	2	3	-	1	-	-	1

CourseName: Fundamentals of Operating System

Course Code: EC604D

Contact: 3:0:0

Total Contact Hours: 36

Credits: 3

Prerequisites:

Computer organization, Computer Architecture, Data Structures, Algorithms & Programming Concept

Course Outcomes:

CO1: Describe how computing resources (such as CPU, memory and I/O) are managed by the operating system.

CO2: Analyze kernel and user mode in an operating system.

CO3: Solve different CPU scheduling problems to achieve specific scheduling criteria.

CO4: Apply the knowledge of process management, synchronization, deadlock to solve basic problems.

CO5: Evaluate and report appropriate design choices when solving real-world problems

Course Contents:

Module-1:

[3L]

Functionalities of Operating System, Evolution of Operating System.

Types of Operating System: batch, multi-programmed, time-sharing, real-time, distributed, parallel, Structural overview, Protection & Security.

Module – 2:

[10L]

Processes: Concept of processes, process states, PCB, process scheduling, co-operating processes, independent process, suspended process, Interaction between processes and OS, Inter-process communication: Message passing.

[3L]

Threads:overview,benefitsofthreads, userandkernellevelthreads, Threadmodels. [2L]

CPU scheduling:schedulingcriteria,preemptive&non-preemptivescheduling,schedulingalgorithms(FCFS,SJF,SRTF,RR,priority,multilevelqueue,multilevelfeedbackqueuescheduling)[5L]

Module – 3:

[11L]

Process Synchronization: background,criticalsectionproblem,synchronizationhardware,classical problems of synchronization(producer-consumer, readers-writer, dining philosophers,etc),semaphores,monitors.[6L]

Deadlocks:deadlockcharacterization,methods forhandlingdeadlocks,deadlockprevention,deadlockavoidance,deadlockdetection,recoveryfromdeadlock.

[5L]

Module-4:

[6L]

Background,logicalvs.physicaladdressspace,swapping,contiguousmemoryallocation,paging,Segmentation,TLB.

[3L]

VirtualMemory: background,demandpaging,pagereplacement algorithms(FCFS,LRU,Optimal),thrashing,Workingsetmodel.

[3L]

Module – 5:

[6L]

Diskstructure,diskscheduling(FCFS,SSTF,SCAN,C-SCAN,LOOK,C-LOOKetc),diskreliability,diskformatting,bootblock,badblocks.

[2L]

File: Fileconcept,accessmethods,directorystructure, filesystemstructure, UNIX filestructure, allocation methods (contiguous, linked,indexed), free-space management (bit vector) [2L]

I/O: I/O hardware, polling,interrupts, DMA, caching, buffering, blocking-non blocking I/O.[2L]

TextBooks:

1. AbrahamSilberschatz,PeterB.Galvin, GregGagne, OperatingSystemConcepts.
2. OperatingSystems&SystemsProgrammingbyPBalakrishnaPrasad

ReferenceBooks:

1. DietelH.N.,“AnIntroductiontoOperatingSystems”,AddisonWesley.
2. AndrewTanenbaum,ModernOperatingSystems,PrenticeHall.
3. WilliamStallings,OperatingSystems,PrenticeHall.

CO-PO-PSO MAPPING:

COs	PO1	PO2	PO3	PO4	PO5	PO6	PO7	PO8	PO9	PO10	PO11	PO12	PSO1	PSO2	PSO3
CO1	3	3	-	-	3	-	-	-	-	-	-	3	-	-	1
CO2	3	3	-	-	-	-	-	-	-	-	-	2	-	-	1
CO3	2	2	-	-	-	-	2	-	-	-	-	3	-	-	-
CO4	3	2	-	-	-	-	3	-	-	-	-	2	-	-	-
CO5	3	2	-	-	-	-	-	-	-	-	-	2	-	-	1

Course Name: DATABASE MANAGEMENT SYSTEM

Course Code: EC605A

Contact:3:0:0

Total Contact Hours: 36

Credits: 3

Prerequisite:

Logicofprogramminglanguage

Basicconceptsofdatastructureandalgorithms

CourseOutcomes:

CO1:Tolearn the datamodels,conceptualizeanddepictadatabase system

CO2: To design system using E-R diagram.

CO3:TolearnSQL &relationaldatabasedesign.

CO4:Tounderstandtheinternalstoragestructuresusingdifferentfileandindexingtechniques.

CO5:Toknowtheconceptsoftransaction processing,concurrencycontroltechniquesandrecoveryprocedure.

Course Content

Module1:Introduction [3L]

Concept&OverviewofDBMS,DataModels,DatabaseLanguages,DatabaseAdministrator,DatabaseUsers, ThreeSchemaarchitectureof DBMS.

Module2:Entity-RelationshipandRelationalDatabaseModel [11L]

Basic concepts, Design Issues, Mapping Constraints, Keys, Entity-Relationship Diagram,WeakEntitySets,ExtendedE-Rfeatures,casestudyonE-RModel.StructureofrelationalDatabases,RelationalAlgebra,RelationalCalculus,ExtendedRelationalAlgebraOperations, Views,ModificationsOf theDatabase.

Module3:SQLandIntegrityConstraints [6L]

Concept of DDL, DML, DCL. Basic Structure, Set operations, Aggregate Functions, Null Values, Domain Constraints, Referential Integrity Constraints, assertions, views, Nested Subqueries, Database security application development using SQL, Stored procedures and triggers.

Module4:RelationalDatabaseDesign [8L]

Functional Dependency, Different anomalies in designing a Database., Normalization using functional dependencies, Decomposition, Boyce-Codd Normal Form, 3NF, Normalization using multi-valued dependencies, 4NF, 5NF, Case Study

Module5:Internalsof RDBMS [9L]

Physical data structures, Query optimization: join algorithm, statistics and cost based optimization. Transaction processing, Concurrency control and Recovery Management: transaction model properties, state serializability, lock based protocols; two phase locking, Dead Lock handling.

Module6:FileOrganization&IndexStructures [6L]

File & Record Concept, Placing file records on Disk, Fixed and Variable sized Records, Types of Single-Level Index (primary, secondary, clustering), Multilevel Indexes

TextBooks:

1. Henry F. Korth and Silberschatz Abraham, "Database System Concepts",
2. Mc. Graw Hill. Elmasri Ramez and Navathe Shamkant, "Fundamentals of Database Systems", Benjamin Cummings Publishing Company.
3. Ramakrishnan: Database Management System, McGraw-Hill
4. Gray Jim and Reuter Address, "Transaction Processing: Concepts and Techniques", Morgan Kaufmann Publishers
5. Ullman J.D., "Principles of Database Systems", Galgotia Publication.

ReferenceBooks:

1. Jain: Advanced Database Management System CyberTech

2. Date C.J., "Introduction to Database Management", Vol. I, II, III, Addison Wesley.
3. "Fundamentals of Database Systems", Ramez Elmasri, Shamkant B. Navathe, Addison Wesley Publishing Edition
4. "Database Management Systems", Arun K. Majumdar, Pritimay Bhattacharya, Tata McGraw Hill

CO-PO Mapping:

CO	PO1	PO2	PO3	PO4	PO5	PO6	PO7	PO8	PO9	PO10	PO11	PO12	PSO1	PSO2	PSO3
CO1	2	2	2	2	3	2	1	1	2	2	3	3	2	3	3
CO2	2	3	3	3	3	1	1	1	2	2	3	3	2	3	3
CO3	3	3	2	3	3	2	2	2	3	3	3	3	3	3	3
CO4	3	3	2	2	2	1	1	1	1	1	2	3	1	2	3
CO5	3	3	3	3	3	2	2	2	3	3	3	3	3	3	3
AVG	2.6	2.8	2.4	2.6	2.8	1.6	1.4	1.4	2.2	2.2	2.8	3	2.2	2.8	3

CourseName:3D Printing & Design

Course Code: EC605B

Contact:3:0:0

ContactHours:36

Credits:3

Prerequisite:ComputerAidedDesign&Drafting,EngineeringMaterials

CourseOutcomes:

CO1:DevelopCAD modelsfor3Dprinting.

CO2:ImportandExportCADdataandselectaspecificmaterialforthegivenapplication.CO3:Selecta3D printing processfor anapplication.

CO4:Produceaproductusing3DPrintingorAdditiveManufacturing(AM).

CourseContents:

Module 1: 6L

Introduction:

Introduction to 3D Printing, Overview of additivemanufacturing techniques, Additive v/s Conventional Manufacturing processes,Applications.

Module 2: 5L

CADforAdditiveManufacturing:CADDDataformats,Slicing,Data translation,Data loss,STLformat

Module 3:

10L

3DPrinting:Process,Equipment,Processparameter,ProcessSelectionforvarious applications. Application Domains: Aerospace, Electronics, Health Care, Defence, Automotive,Construction,FoodProcessing,MachineTools

Module 4: 5L

Materials:Polymers,Metals,Non-Metals,Processparameter,ProcessSelectionfor variousapplications. Variousformsofrawmaterialandtheirdesiredproperties,SupportMaterials

Module 5: 5L

Core issues in 3D Printing:

Design and process parameters, Governing Bonding Mechanism, Common faults and troubleshooting

Module 6:

5L

Post Processing: Requirement and Techniques

Support Removal, Sanding, Acetone treatment, polishing, Inspection and testing, Defects and their causes

Text Books:

1. Khanna Editorial, "3D Printing and Design", Khanna Publishing House, Delhi.
2. Andreas Gebhardt, "Understanding Additive Manufacturing: Rapid Prototyping, Rapid Tooling, Rapid Manufacturing", Hanser Publisher, 2011.
3. Amitava Ghosh, Rapid Prototyping, McGraw Hill Publishers.
4. J.D. Majumdar and I. Manna, "Laser-Assisted Fabrication of Materials", Springer Series in Material Science, 2013.
5. Ian Gibson, David W. Rosen and Brent Stucker, "Additive Manufacturing Technologies: Rapid Prototyping to Direct Digital Manufacturing", Springer, 2010

CO- PO Mapping

COs	PO 1	PO 2	PO 3	PO 4	PO 5	PO 6	PO 7	PO 8	PO 9	PO 10	PO 11	PO 12	PSO 1	PSO 2	PSO 3
CO 1	2	2	3	-	3	-	-	-	-	-	1	1	-	-	-
CO 2	2	2	3	-	3	-	-	-	-	-	1	1	-	-	-
CO 3	2	2	3	-	3	2	2	-	-	-	1	1	-	-	-
CO 4	3	2	3	2	3	-	2	-	-	-	2	1	-	-	-

Course Name: Web Intelligence & Bigdata

CourseCode: EC605C

Contact:3:0:0

TotalContactHours:36

Credits:3

Prerequisite:

ProbabilityandStatistics,DatabaseManagementSystem(SQL-QueriesandSubqueries)
,KnowledgeinC,Python, R,ProficiencyinAlgorithm,LINUX

CourseOutcomes:

AftersuccessfullycompletingthecoursetheUndergraduatestudentswillbeableto:

CO1:UnderstandWebIntelligenceandBigdatafundamentals.CO2:InvestigatevariousDataAnalysisTec
hniques.

CO3: AnalyzeMachineLearningAlgorithmsusingR.

CO4:ImplementHadoop,MapReduceandNOSQLinbigdataanalytics.

CO5: Apply Hadoop ecosystem components for business and
scientificcomputing.

CourseContent:

Module1:

[3L]

WEBINTELLIGENCE

ConceptsofWebIntelligence: benefits,ingredientsandrelatedtechnologies.

Module2:

[3L]

WEBMINING

WebUsageMining, WebContentMining, WebStructureMining

Module3:

[7L]

INTRODUCTIONTOBIGDATAWITHHADOOP

IntroductiontoBigData–Types of digital data and challenges of conventionaldata, BigDataAnalytics- AnalysisandReporting, ConceptofHadoop, ApacheHadoop, Moderndataanalytictools-Data analysis with Unix tools, Analysis ofData with Hadoop, Data Analysis with Spertk and Impala, Introduction to HadoopStreaming, HadoopEchoSystem, IBMBigData.

Module4:

[7L]

STATISTICSANDDATAANALYTICS

Stasticalconcepts: Sampling, Resampling, Statisticalinference, Statisticalhypothesisgenerationandtestin g, Chi-square test, t-Test, Analysisof variance, Prediction error, Regression modeling, Multivariate analysis, Bayesian modeling ,inferenceandBayesiannetworks.

Module5:

[5L]

RMACHINELEARNING

IntroductiontoSupervisedLearning- Classification, SupportvectorandKernelmethods, UnsupervisedLearning-Clustering, Big Data Association RuleAnalysis-Neuralnetworks, FuzzyLogic:extractingfuzzymodels from data ,fuzzydecisiontrees, Stochasticsearchmethods, DataanalysiswithR

Module6:

[4L]

INTRODUCTIONTOHDFS(HADOOPDISTRIBUTEDFILESYSYTEM)

Introduction to HDFS, Command Line Interface, Hadoop file system interfaces, Dataflow, DataIngest- Flume, ScoopandHadooparchives, HadoopI/O: CompressionandSerialization. AvroandFile- BasedDatastructures.

Module7:**[3L]****MAPREDUCE**

Map Reduce Types and Formats, Map Reduce Features, Anatomy of Map ReduceJobRun,Failures,JobScheduling,ShuffleandSort,TaskExecution,NO-SQL.

Module8:**HADOOPECOSYSTEM****[4L]**

Hadoopecosystemcomponents-Schedulers,FairandCapacity,HDFS Federation, MRv2, YARN, , Hive Architecture and Installation, Comparison ofHIVEwithTraditionalDatabase,HiveQL-QueryingDataanduserdefinedfunctions,IntroductiontoHbase,ClientsconceptandExample,HbaseVersusRDBMS,IntroductiontoPIG,Zookeeper

TextBooks:

1. Akerkar, R. & Lingras, P. (2008). Building an Intelligent Web: Theory andPractice. Jonesand Bartlett Publishers, Sudbury, Massachusetts. ISBN-13:978-0-7637-4137-2
2. ChrisEaton,Dirkderoosetal.,“UnderstandingBigdata”,McGrawHill, 2012.
3. TomWhite,“HADOOP:TheDefinitiveGuide”,OReilly2012.
4. SeemaAcharya,SubhasiniChellappan,"BigDataAnalytics"Wiley2015.

ReferenceBooks:

5. Witten,IanH.&Frank,E.(2005).DataMining:PracticalMachineLearningToolsandTechniques.2nd Edition,MorganKaufman.ISBN0120884070,9780120884070
6. MichaelBerthold, David J. Hand, "Intelligent Data Analysis", Springer, 2007.
7. GlennJ. Myatt, Making Sense of Data, John Wiley &sons, 2007 Pete

Warden, BigDataGlossary, O'Reilly, 2011.

8. Vignesh Prajapati, "Big Data Analytics with R and Hadoop", Packet Publishing 2013.
9. JyLiebowitz, "BigDataandBusinessanalytics", CRCpress, 2013.
10. Anand Rajaraman and Jeffrey David Ulman, "Mining of Massive Datasets", Cambridge University Press, 2012.

CO-PO-PSO MAPPING:

COs	PO 1	PO 2	PO 3	PO 4	PO 5	PO 6	PO 7	PO 8	PO 9	PO 10	PO1 1	PO1 2	PSO1	PSO2	PSO3
CO1	3	3	2	2	2	2	-	-	-	-	2	2	-	-	2
CO2	3	2	2	2	3	2	-	-	-	-	2	2	-	-	-
CO3	3	3	3	3	2	2	-	-	-	-	2	2	-	-	2
CO4	3	3	3	2	3	2	-	-	-	-	2	2	-	-	-
CO5	3	3	3	2	3	2	-	-	-	-	2	2	-	-	-

CourseName:SCIENTIFICCOMPUTING

CourseCode: EC605D

Contact:3:0:0

TotalContactHours:36

Credits:3

Prerequisite:

BasicKnowledgeofEngineeringMathematics

CourseOutcomes:

AftersuccessfullycompletingthecoursetheUndergraduatestudentswillbeableto:

CO1:Understandthedifferentialalgorithmsandtheirsolutionsinmathematics.

CO2:InvestigatevariouscryptographTechniques.

CO3:Analyzevariousortingalgorithms.

CO4: Implement mathematics for solution of various scientific findingcomputions.

CourseContent:

Module1:

[10L]

EuclideanAlgorithm,FastFourierTransform,IntegerandPolynomialarithmetic,PolynomialEquation-solutionofsystems.

Module2:

[10L]

Codingandcryptographetechniques, Matrixmanipulation, Fastalgorithmsformatrix,seriesetc.ModernApplicationsincryptography.

Module3:

[9L]

ModernSortingalgorithms,Solutionofdifferentialequations,Symbolicintegration

Module4:

[7L]

Control Theory, Stability, Applications

TextBooks:

1. Akerkar, R. & Lingras, P. (2008). Building an Intelligent Web: Theory and Applications. John Wiley & Sons, Inc., ISBN 0471000051
1. T. M. Apostol. Calculus, Vol. 1: One-Variable Calculus with an Introduction to Linear Algebra. John Wiley & Sons, Inc., ISBN 0471000051
2. T. M. Apostol. Calculus, Vol. 2: Multi-Variable Calculus and Linear Algebra, with Applications to Differential Equations and Probability. John Wiley & Sons, Inc., ISBN 9780471000075.

ReferenceBooks:

1. J. von zur Gathen and J. Gerhard. Modern Computer Algebra. Cambridge University Press, 3rd ed., 2013. ISBN 9781107039032
2. J.A. Storer. An Introduction to Data Structures and Algorithms. Springer, 2002. ISBN 978-1-4612-0075-8
3. D. Sankoff, J. Kruskal. Time Warps, String Edits, and Macromolecules. The Theory and Practice of Sequence Comparison (CSLI Pub., 1999) ISBN 9781575862170
4. A. Masoudi-Nejad, Z. Narimani, N. Hosseinkhan. Next Generation Sequencing and Sequence Assembly: Methodologies and Algorithms. Springer, 2013, ISBN 978-1-4614-7725-9.

CO-PO-PSO MAPPING:

COs	PO1	PO2	PO3	PO4	PO5	PO6	PO7	PO8	PO9	PO10	PO11	PO12	PSO1	PSO2	PSO3
CO1	3	3	2	2	2	2	-	-	-	-	2	2	-	-	1
CO2	3	2	2	2	3	2	-	-	-	-	2	2	-	-	-
CO3	3	3	3	3	2	2	-	-	-	-	2	2	-	-	1
CO4	3	3	3	2	3	2	-	-	-	-	2	2	-	-	1
AVG	3	2.75	2.5	2.25	2.5	2					2	2			1

Course Name: VLSI & Microelectronics Lab

Course Code: EC691

Contact: 0:0:3

Credit: 1.5

Course Outcome:

Upon the completion of the course the students will be able to

CO1: Understand V_{IL} , V_{IH} , V_{OL} , V_{OH} , noise margin, gate delay and average power consumption of CMOS inverter for V_{DD} in between 0.5V - 1.2 V using nano dimensional channel length of MOS transistor following DC & transient analysis with the help of SPICE tools.

CO2: Design & explain the working of basic gates-AND/NAND, OR/NOR, XOR/XNOR gate; full adder circuit; sequential circuit -SR latch, clocked SR latch & D flip-flop using CMOS design method at schematic level for the V_{DD} range 0.5 V to 1.2 V at nano dimensional channel length with the help of SPICE tools.

CO3: Construct the layout & examine the functionality of CMOS inverter, CMOS NAND, CMOS NOR gate using SPICE layout design tools based on design rules for V_{DD} 0.5 V to 1.2 V.

CO4: Design combinational circuits - logic gates, half adder, full adder, 4:1 MUX using 2:1 MUX ; sequential circuits-S-R flip-flop, 8-bit synchronous counter, 8-bit bi-directional register with help of behavioural , dataflow , structural & mixed modelling style through VHDL code and able to demonstrate system design using FPGA at prototype level .

CO5: Design CMOS differential amplifier with active load and biased with current mirror using nano dimensional channel length of MOS transistors with the help of SPICE tools at schematic level.

List of Experiments:

1. Simulation of CMOS inverter to plot voltage transfer characteristics (VTC) for different values of k_n/k_p ratio for $V_{DD}=1$ V and nano dimensional channel length using SPICE.
 - a. Measurement of critical voltages $V_{IL}, V_{IH}, V_{OL}, V_{OH}$ from VTC.
 - b. Calculation of noise margin from critical voltages.

2. Functional verification, measurement of gatedelay and average power consumption of CMOS inverter circuit for V_{DD} range 0.5 V to 1.2 V and with the nanodimensional channel length of MOS transistor using SPICE tools.
3. Design and testing of functionality of the following gate and combinational circuit with the help of SPICE tools at schematic level.
 - a. CMOS AND/NAND, OR/NOR, XOR/XNOR gate
 - b. CMOS full adder circuit.
4. Layout design and functional verification of CMOS inverter, CMOS NAND, CMOS NOR gate using layout design tool of SPICE based on design rules.
5. Design and examination of functionality of the sequential circuits - CMOS SR latch, clocked SR latch & D flip-flop at schematic level using SPICE tools .
6. Design and simulation of a) Logic gates b) Full adder using half adder c) 4:1 MUX using 2:1 MUX with the help of VHDL following suitable modelling style (structural, behavioral, dataflow, mixed).
7. Design of the following Sequential circuits using VHDL
 - a. S-R Flip-Flop
 - b. 8 bit synchronous counter
 - c. 8 Bit bi-directional register with tri-stated input/output.
8. Familiarity with FPGA based system design. Design and realization of 4:1 Mux using FPGA.
9. Design of CMOS differential amplifier at schematic level with active load and current mirror bias circuit for given specifications using SPICE tools.
10. Innovative experiment.

CO-PO-PSO Mapping:

	PO1	PO2	PO3	PO4	PO5	PO6	PO7	PO8	PO9	PO10	PO11	PO12	PSO1	PSO2	PSO3
CO1	3	3	3	3	-	-	-	-	3	2	-	3	3	2	-
CO2	3	3	3	3	-	-	-	-	3	2	-	3	3	2	-
CO3	3	2	3	3	-	-	-	-	3	2	-	3	3	2	-
CO4	3	3	3	3	-	-	-	-	3	2	-	3	3	2	-
CO5	3	2	3	3	3	-	-	-	3	2	-	3	3	1	-

Course Name: Control Systems Lab

Course Code: EC692

Contacts: 0:0:3

Credit: 1.5

Course Outcomes:

Upon the completion of the course the students will be able to

CO1: Understand different types of electrical, mechanical and electromechanical systems.

CO2: Determine transient and steady state behaviour of different types of systems using standard test signals.

CO3: Determine the importance of gain, location of poles and zeros to design a system.

CO4: Check the stability of the systems using the concept of different stability criterion.

CO5: Design the systems according to the desired specifications or requirements using different types of controller and compensator.

List of Experiments:

1. Familiarization with MATLAB Control System Toolbox and SIMULINK.
2. Study of the effect of feedback on systems.
3. Study of first order systems having different time constants.
4. Study of second order systems having different damping ratios.
5. Study of time response of different electrical and mechanical systems.
6. Verification and validation of time domain specifications of second order systems.
7. Study of steady state errors for different 'types' of systems.
8. Study of system stability using Root locus technique.
9. Determination of Bode-plot and computation of gain crossover frequency, phase crossover frequency, gain margin and phase margin using MATLAB.
10. Study of closed loop stability using Nyquist plot.
11. Study of system representation using State Model.
12. Determination of PI, PD and PID controller action on first order simulated process.
13. Evaluation of steady-state error, setting time, percentage peak overshoots, gain margin and phase

Course Name: Object Oriented ProgrammingLab

Course Code: EC694A

Contact:0:0:3

Credits:1.5

Prerequisites:

1. ComputerFundamentals
2. BasicunderstandingofComputerProgrammingandrelatedProgrammingParadigms
3. ProblemSolvingTechniqueswithproperlogicImplementation.

Course Outcomes:

Upon the completion of the course the students will be able to

CO1: Create the procedure of communication between Objects, classes & methods.

CO2: Understand the elementary facts of Object Orientation with various characteristics as well as several aspects of Java.

CO3: Analyze distinct features of different string handling functions with various I/O operations.

CO4: Discuss simple Code Reusability notion w.r.t. Inheritance, Package and Interface.

CO5: Apply Exception handling, Multithreading and Applet (Webprogram in java) programming concept in Java.

Course Contents:

Module1:JavaBasics:

1. SimpleJavaprogrammingusingoperators,controlstatements&loops,array.
2. Programmingonclass,object,and method,accessspecifier.
3. Programmingonconstructor, method/constructoroverloading.
4. Programmingon thiskeyword,call by value& call by reference,staticvariables&methods,innerclasses.

Module2:BasicString handling &I/O:

1. ProgrammingtoshowtheuseofStringclassmethods-charAt(),compareTo(),equals(),equalsIgnoreCase(),indexOf(), length() , substring(), toCharArray(), toLowerCase(), toString(),toUpperCase(),trim(),valueOf()methods.
2. Programming to show the use of StringBuffer class methods - append(), capacity(),

charAt(),delete(), deleteCharAt(),ensureCapacity(), getChars(), indexOf(), insert(), length(), setCharAt(),setLength(),substring(),toString()methods.

3. ProgrammingonCommandlinearguments.
4. Programmingusingkeyboard inputbyimplementingBufferedReader&Scannerclasses.

Module3:Inheritance,InterfaceandJavaPackages:

1. ProgrammingonSimpleInheritance,super andfinalkeywords,super()method.
2. Programmingonmethodoverriding,dynamicmethoddispatch,abstractclasses&methods,multi pleinheritancebyusinginterface.
3. Programmingonimportingsystempackage,creatinguser-definedpackage,importinguser-defined package, using protected access specifier, subclassing an imported class of a package,usingsamenamesforclassesofdifferentpackages, addingmultiplepublicclassestoapackage.

Module4: Exceptionhandling,MultithreadingandAppletProgramming:

1. Programmingonexceptionhandlingusingtry-catchblock,implementingthrowandthrowskeywords,usingfinallyblock,creatinguser-definedexception.
2. Programmingoncreatingchildthreadsi)byextendingthreadclassii)byimplementingrunnableinterface,creatingchildthreadsbyassigningthreadpriorities.
3. Programmingoncreatingsimpleapplettodisplaysomemessage,creatingapplettwoadd2integers, creatingapplettodoGUIbasedprogramming.

Textbooks:

1. HerbertSchildt-"Java:TheComplete Reference"-9thEd.-TMH
2. E.Balagurusamy- "ProgrammingWithJava: APrimer"-3rdEd.-TMH.

ReferenceBooks:

1. R.KDas-"CoreJavafor Beginners"-VIKASPUBLISHING.

Rambaugh,JamesMichael,Blaha-"ObjectOrientedModellingandDesign"-PrenticeHall,India

CO-PO-PSO Mapping:

	PO1	PO2	PO3	PO4	PO5	PO6	PO7	PO8	PO9	PO10	PO11	PO12	PSO1	PSO2	PSO3
CO1	3	2	2	-	1	1	-	-	3	-	1	1	3	2	2
CO2	2	3	2	-	3	1	-	-	3	-	-	-	3	2	2
CO3	3	3	2	-	3	2	-	-	3	-	1	1	3	2	2
CO4	2	3	1	-	2	3	-	-	3	-	-	-	3	2	1

CourseName: Fundamentals of Sensors and Transducers Lab

CourseCode: EC694B

Contact: 0:0:3

Credits: 1.5

Course Outcome:

Graduates of the ECE program will be able to:

- CO1:** Illustrate the working of transducers and various transducers used for the measurement of various physical variables.
- CO2:** Analyze the characteristics of the transducers.
- CO3:** Design sensor based on the real-time application.
- CO4:** Estimate the design specifications of different transducers.

List of Experiment:

1. Displacement measurement by using a capacitive transducer.
2. Pressure and displacement measurement by using LVDT.
3. Study of a load cell with tensile and compressive load.
4. Torque measurement using a strain gauge transducer.
5. Speed measurement using a magnetic proximity sensor.
6. Speed measurement using a Stroboscope.
7. Study of the characteristics of an LDR.
8. Pressure measurement using a Piezo-electric transducer.
9. Study of the Characteristics of Hall-effect transducer.
10. Innovative experiment.

Textbooks:

1. Patranabis, "Sensors and Transducers", 2nd Edition, Prentice Hall India Pvt. Ltd
2. Murthy D. V. S, "Transducers and Instrumentation", Prentice Hall, New Delhi..
3. Doebelin E. O, "Measurement Systems - Application and Design", 4th Edition, McGraw-Hill, New York, 2003

Reference Books:

1. Neubert H. K. P, "Instrument Transducers - An Introduction to their Performance and Design", 2nd Edition, Oxford University Press, Cambridge.
2. Waldemar Nawrocki, "Measurement Systems and Sensors", Artech House.
3. S. M. Sze, "Semiconductor sensors", John Wiley & Sons Inc., Singapore.
4. John Brignell, "Intelligent Sensor Systems", CRC Press; 2nd Revised edition, 1996

CO-PO Mapping:

CO	PO1	PO2	PO3	PO4	PO5	PO6	PO7	PO8	PO9	PO10	PO11	PO12	PSO1	PSO2	PSO3
CO1	3	2	-	-	1	-	-	-	2	-	1	1	1	-	-
CO2	1	2	-	3	-	1	-	1	-	2	-	1	1	1	-
CO3	1	2	1	-	2	-	1	-	3	-	-	2	-	-	-
CO4	1	2	-	1	-	1	-	-	-	3	-	1	-	2	-
AVG	1.5	2	1	2	1.5	1	1	1	2.5	2.5	1	1.25	1	1.5	

CourseName:IntroductiontoQuantumComputingLab

CourseCode: EC694C

Contacts:0:0:3

Credit:1.5

Prerequisite:LinearAlgebra(MatrixandDeterminant),Tensorproduct,Cprogramming,DataStructure andAlgorithm,Programming in Python/C#,quantum physicsandmechanics

CourseOutcomes:

GraduatesoftheECEprogramwillbeableto:

- CO1: Identifyquantumgatesandcircuits
- CO2: Explain the working of a Quantum Computing program, its architecture and programmodel
- CO3: Design error correction circuits using quantum gates
- CO4: Developquantumalgorithmprogramonmajortoolkits
- CO5: Handlecomplexprojectsonquantumcircuits

CourseContent:Any8Experiments.

- Experiment1:** WriteaCprogramtoimplement $|0\rangle$ and $|1\rangle$.
- Experiment2:** WriteaCprogramtoimplement $|00\rangle,|01\rangle,|10\rangle$ and $|11\rangle$.
- Experiment3:** Writea Cprogramto verifyacomplexelementmatrixtobeHermitian.**Experiment4:** WriteaCprogramtoimplementVandV+gatesusingmatrixrepresentation.**Experiment5:** Experimentallyprovethat V^2 or $V+2=$ CNOTusingmatrixalgebra.
- Experiment6:** WriteaCprogramtoimplement2-inputToffoligateusingmatrixalgebra.
- Experiment7:** UsingCprogram,implementHadamardgate.
- Experiment8:** Experimentallyprovethat $VV+=I$ whereIisanidentitymatrix.
- Experiment9:** WriteaCprogramtoimplementa Peresgateusingmatrixalgebra.

Experiment 10: Using RCviewer or RCviewer+, design a half adder and a full adder and decompose into quantum circuits.

Experiment 11: Using RCviewer or RCviewer+, design a 4 to 1 multiplexer using Fredkin gate and decompose into quantum circuits.

Experiment 12: Using RCviewer or RCviewer+, design a full adder using Fredkin gate and decompose into quantum circuits.

Experiment 13: Building Quantum dice

Experiment 14: Building Quantum Random No. Generation

Experiment 15: Composing simple quantum circuits with q-gates and measuring the output into classical bits.

Experiment 16: Implementation of Shor's Algorithms

Textbooks:

1. "Quantum Computation and Quantum Information", Michael A. Nielsen & Isaac L. Chuang, Cambridge University Press
2. Quantum computing for computer scientists, N. S. Yanofsky, Mirco A. Mannucci, Cambridge University Press 2008

References:

1. Quantum computing explained, David McMahon, Wiley-Interscience, John Wiley & Sons, Inc. Publication 2008
2. Riley Tipton Perry, "Quantum Computing from the Ground Up", World Scientific Publishing Ltd (2012).
3. P. Kok, B. Lovett, "Introduction to Optical Quantum Information Processing", Cambridge (2010).
4. Scott Aaronson, "Quantum Computing since Democritus", Cambridge (2013).
5. Introduction to Quantum Mechanics, 2nd Edition, David J. Griffiths, Prentice Hall New Jersey 1995
6. Online math tutorial: <http://patrickjmt.com/>
7. <https://www.coursera.org/learn/quantum-computing-algorithms>
8. IBM Experience: <https://quantumexperience.ng.bluemix.net>
9. Microsoft Quantum Development Kit <https://www.microsoft.com/en-us/quantum/development-kit>
10. Forest SDK PyQuil: <https://pyquil.readthedocs.io/en/stable/>

CO-PO Mapping:

CO	PO1	PO2	PO3	PO4	PO5	PO6	PO7	PO8	PO9	PO10	PO11	PO12	PSO1	PSO2	PSO3
CO1	3	-	-	-	-	2	-	-	1	-	-	-1	-	-	1
CO2	-	-	3	2	-	-	-	1	-	1	-	-	-	-	1
CO3	2	2	-	3	-	1	-	-	-	-	1	-	-	-	-
CO4	-	-	-	-	2	-	1	-	-	-1	-	-	-	-	-
CO5	3	-	2	-	1	-	-	-	1	-	1	-	-	-	-
AVG	2.7	2.0	2.5	2.5	1.5	1.5	1.0	1.0	1.0	0.0	1.0	1.0			1.0

Course Name: Operating Systems Lab

Course Code:EC694D

Contacts:0:0:3

Credits:1.5

Prerequisites:

1. Computer organization
2. Computer Architecture
3. Data Structures
4. Algorithms & Programming Concept

Course Outcomes:

Graduates of the ECE program will be able to:

- CO1:** To Analyze different aspects of Linux.
- CO2:** To Create or design different scripts using shell programming.
- CO3:** To implement process, thread, semaphore concept of operating system.
- CO4:** Create shared memory with the implementation of reading from, write into shared memory.

List of Experiments:

1. Essential Linux Commands [9P]:

Commands for files and directories cd, cp, mv, rm, mkdir, more, less, creating and viewing files, using cat, file comparisons, View files, kill, ps, who, sleep, grep, fgrep, find, sort, cal, banner, touch, file related commands – ws, sat, cut, grep etc. Mathematical commands – expr, factor, units, Pipes (use functions pipe, popen, pclose), named Pipes (FIFOs, accessing FIFO)

2. Shell Programming [6P]:

Creating a script, making a script executable, shell syntax (variables, conditions, control structures, functions, and commands).

3. Process[3P]:

Starting new process, replacing a process image, duplicating a process image.

4. Semaphore[3P]:

Programming with semaphores (use functions semget, semop, semaphore_p, semaphore_v).

5. POSIX Threads[6P]:

Programming with pthread functions
(viz. pthread_create, pthread_join, pthread_exit, pthread_attr_init, pthread_cancel)

6. Shared Memory[9P]:

Create the shared memory, Attach the shared memory segment to the address space of the calling process, read information from the standard input and write to the shared

memory, Read the content of the shared memory and write onto the standard output

Delete the shared memory

Textbooks:

Yashavant P. Kanetkar, UNIX Shell Programming, 1st edition, BPB Publications Beej's Guide to Unix IPC

Reference Books:

W. Richard Stevens, UNIX Network Programming, 2nd edition, Prentice Hall

CO-PO Mapping:

COs	PO1	PO2	PO3	PO4	PO5	PO6	PO7	PO8	PO9	PO10	PO11	PO12	PSO1	PSO2	PSO3
CO1	3	-	-	-	1	1	-	2	-	-	-	3	-	-	-
CO2	-	3	3	3	-	-	-	-	1	-	1	3	-	-	-
CO3	2	-	-	2	-	1	-	1	-	1	-	-	-	-	-
CO4	-	3	3	-	-	-	3	-	2	-	-	1	-	-	-
AVG	2.5	3	3	2.5	1	1	3	1.5	1.5	1	1	2.3			

Course Name: DATABASE MANAGEMENT SYSTEM LAB

Course Code: EC695A

Contact: 0:0:3

Credits: 1.5

Prerequisite:

Logic of programming language

Basic concepts of data structure and algorithms

Course Outcomes:

Graduates of the ECE program will be able to:

CO1: Understand the basic concepts regarding database, know about query processing and techniques involved in query optimization and understand the concepts of database transaction and related database facilities including concurrency control, backup, and recovery.

CO2: Understand the introductory concepts of some advanced topics in data management like distributed databases, data warehousing, deductive databases and be aware of some advanced databases like partial multimedia and mobile databases.

CO3:

Differentiate between DBMS and advanced DBMS and use of advanced database concepts and be come proficient in creating database queries.

CO4: Analyze database system concepts and apply normalization to the database.

CO5: Apply and create different transaction processing and concurrency control applications.

ExperimentDetails:

1. Structured QueryLanguage
2. CreatingDatabaseCreatingaDatabase
3. CreatingaTableSpecifyingRelationalDataTypesSpecifyingConstraints
4. CreatingIndexesTableandRecordHandlingINSERTstatement
5. UsingSELECTandINSERTtogetherDELETE,UPDATE,TRUNCATEstatementsDROP,ALTER statements
6. RetrievingDatafromaDatabasetheSELECTstatementUsingtheWHEREclause.
7. UsingLogical Operatorsin the WHEREclause
8. UsingIN,BETWEEN,LIKE,ORDERBY,GROUPBYandHAVINGClauseUsingAggregateFunctions
9. CombiningTablesUsingJOINS Sub-queriesDatabaseManagementCreatingViews
10. CreatingColumnAliasesCreatingDatabase UsersUsingGRANTandREVOKEPL/SQL
11. DatabasedesignusingE-RmodelandNormalization
12. Design and implementation of some online system [Library Management System]

Textbook:

1. SQL, PL/SQLbyIvanBayross,BPBPublications
2. OraclePL/SQLProgramming,6thEdition-O'ReillyMediaByStevenFeuerstein,BillPribyl

CO-PO-PSO MAPPING

	PO1	PO2	PO3	PO4	PO5	PO6	PO7	PO8	PO9	PO10	PO11	PO12	PSO1	PSO2	PSO3
CO1	2	2	2	2	-	-	-	-	2	2	3	3	-	-	2
CO2	2	3	3	3	-	-	-	-	2	2	2	3	-	-	2
CO3	3	3	2	-	-	-	-	-	3	3	3	1	-	-	2
CO4	3	2	2	2	2	-	-	-	1	1	-	3	-	-	2
CO5	3	3	3	3	3	-	-	-	3	3	3	3	-	-	2

Course Name: 3D Printing & Design Lab

CourseCode:EC695B

Contacts:0:0:3

Credit: 1.5

Prerequisite:

Knowledgeofcomputerandmathematics.

CourseOutcomes:

GraduatesoftheECEprogramwillbeableto:

CO1:AnalyzeCADtoolsfordifferentdesign.

CO2:Apply2DmodelusingCADtools.

CO3:Apply3DmodelusingCADtools.

CO4:Conceptualize and visualize their designs

ExperimentDetails:

1. IntroductiontothedifferentfeaturesofCADsoftwares.
2. Tomakeagiven2-Ddrawing usingCADsoftware.
3. Makea3-Ddrawing usingCADsoftware
4. Makea3-Ddrawing usingCADsoftwareasperthefigurebelow:

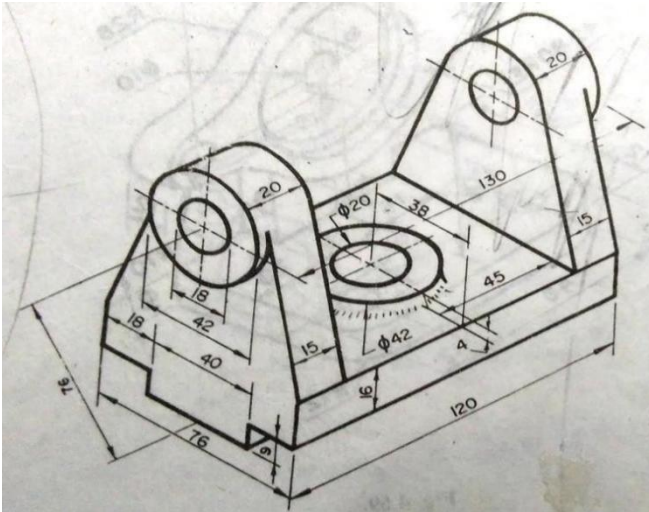

5. Editing a drawing using feature modification and Manipulation

6. Draw a detailed drawing as given below

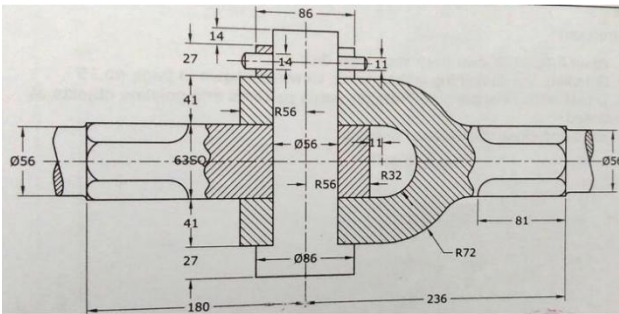

7. To make an object using Sheet metal.

Make a box of given dimensions using a sheet of 0.5mm thickness. Length=60mm Width=40mm Height=50 mm

8. To make a hollow cylindrical object of the given dimensions. Length:50mm Outer Dia:25mm inner Dia:20 mm

9. To solve a one-dimensional problem on finite element method.

Textbooks:

AutoCAD for dummies by Bill Fane, Wiley.

CO-PO-PSO MAPPING

COs	PO1	PO2	PO3	PO4	PO5	PO6	PO7	PO8	PO9	PO10	PO11	PO12	PSO1	PSO2	PSO3
CO1	2	2	2	2	3	2	1	1	2	2	3	3	-	-	-
CO2	2	3	3	3	3	1	1	1	2	2	3	3	-	-	-
CO3	3	3	2	3	3	2	2	2	3	3	3	3	-	-	-
CO4	3	2	2	3	3	2	2	2	2	3	-	2	-	-	-
	2.5	2.5	2.25	2.75	3	1.75	1.5	1.5	2.25	2.5	3	2.75			

Course Name: Web intelligence & Big data laboratory

Course Code: EC695C

Contacts: 0:0:3

Credit: 1.5

Prerequisite: Knowledge in C, Python, R, Proficiency in LINUX, SQL

Course Outcomes:

Graduates of the ECE program will be able to:

- CO1:** Able to configure and run Hadoop and HDFS
- CO2:** Able to apply Map Reduce in practical problems
- CO3:** Implement Hadoop, Map Reduce and NO SQL in big data analytics.
- CO4:** Apply Hadoop ecosystem components for business and scientific computing.

LIST OF EXPERIMENTS

1. Familiarization and install, configure, and run Hadoop and HDFS.
2. Implement word count/frequency programs using Map Reduce.
3. Implement an MR program that processes a weather dataset.
4. Study on Linear and logistic Regression.
5. Implement SVM/Decision tree classification techniques.
6. Study of clustering techniques.
7. Study of data using any plotting framework.

8. Write a program that stores big data in Hbase/MongoDB/Pig using Hadoop /R.

Text Books:

1. Akerkar, R. & Lingras, P. (2008). Building an Intelligent Web: Theory and Practice. Jones and Bartlett Publishers, Sudbury, Massachusetts. ISBN-13: 978-0-7637-4137-2
2. Chris Eaton, Dirk Derost et al., "Understanding Big data", McGraw Hill, 2012.
3. Tom White, "HADOOP: The definitive Guide", O'Reilly 2012.
4. Seema Acharya, Subhasini Chellappan, "Big Data Analytics" Wiley 2015.

Reference Books:

1. Witten, Ian H. & Frank, E. (2005). Data Mining: Practical Machine Learning Tools and Techniques. 2nd Edition, Morgan Kaufman. ISBN 0120884070, 9780120884070
2. Michael Berthold, David J. Hand, "Intelligent Data Analysis", Springer, 2007.
3. Glenn J. Myatt, Making Sense of Data, John Wiley & Sons, 2007. Pete Warden, Big Data Glossary, O'Reilly, 2011.
4. Vignesh Prajapati, "Big Data Analytics with R and Hadoop", Packt Publishing 2013.
5. Jy Liebowitz, "Big Data and Business Analytics", CRC Press, 2013.
10. Anand Rajaraman and Jeffrey David Ullman, "Mining of Massive Datasets", Cambridge University Press, 2012.

CO-PO Mapping:

COs	PO1	PO2	PO3	PO4	PO5	PO6	PO7	PO8	PO9	PO10	PO11	PO12	PSO1	PSO2	PSO3
CO1	3	3	2	2	2	2	-	-	-	-	2	2	-	-	2
CO2	3	2	2	2	3	2	-	1	-	1	2	2	-	-	1
CO3	3	3	3	3	2	2	1	-	1	-	2	2	-	-	-
CO4	3	3	3	2	3	2	-	-	-	-	2	2	-	-	-
AVG	3	2.75	2.5	2.25	2.5	2	1	1	1	1	2	2			1.5

Weightage Values: 3 = Strongly matched, 2 = Moderately matched, 1 = Weakly matched, (-) = Notmatched.

CourseName:SCIENTIFICCOMPUTINGLAB

CourseCode: EC695D

Contact: 0:0:3

Credits:1.5

Prerequisite:Basic KnowledgeofEngineeringMathematics

Course Outcomes:

GraduatesoftheECEprogramwillbeableto:

- CO1: Analyze thevarious computingtools.
- CO2: Applythecomputationtechniquesforcomplexmathematicalproblemsolving.
- CO3: Createthesolutionforagivenproblemusingthetechniquesofscientificcomputing.
- CO4: Applythe various scientificcomputing toolsforproblemsolving.

LISTOFEXPERIMENTS

1. Familiarization ofthevariousComputingTools
2. Basicrequirementsinscientificcomputing
3. Familiarizationwithaprogramminglanguageforscientificcomputing
4. Tobefamiliarizedwithdatatypesinthelanguageused.
5. Tobefamiliarizedwiththesyntax.
6. Understanding thebasicsyntax and executionofprograms.
7. Basicarithmeticfunctionssuchasabs,sine,real,imag,complex,sincetc.

8. Applications in fast scientific areas.
9. Problems solving using mathematical functions and tools.

Text Books:

1. Akerkar, R. & Lingras, P. (2008). Building an Intelligent Web: Theory and
1. T.M. Apostol. Calculus, Vol. 1: One-Variable Calculus with an Introduction to Linear Algebra. John Wiley & Sons, Inc., ISBN 0471000051
2. T.M. Apostol. Calculus, Vol. 2: Multi-Variable Calculus and Linear Algebra, with
3. Applications to Differential Equations and Probability. John Wiley & Sons, Inc., ISBN 9780471000075.

Reference Books:

1. J. von zur Gathen and J. Gerhard. Modern Computer Algebra. Cambridge University Press, 3rd ed., 2013. ISBN 9781107039032
2. J.A. Storer. An Introduction to Data Structures and Algorithms. Springer, 2002. ISBN 978-1-4612-0075-8
3. D. Sankoff, J. Kruskal. Time Warps, String Edits, and Macromolecules. The Theory and Practice of Sequence Comparison (CSLI Pub., 1999) ISBN 9781575862170
4. A. Masoudi-Nejad, Z. Narimani, N. Hosseinkhan. Next Generation Sequencing and Sequence Assembly: Methodologies and Algorithms. Springer, 2013, ISBN 978-1-4614-7725-9.

CO-PO Mapping:

CO	PO1	PO2	PO3	PO4	PO5	PO6	PO7	PO8	PO9	PO10	PO11	PO12	PSO1	PSO2	PSO3
CO1	3	3	2	2	2	2	1	-	1	-	2	2	-	-	2
CO2	3	2	2	2	3	2	-	1	-	-	2	2	-	-	-
CO3	3	3	3	3	2	2	1	-	1	-	2	2	-	-	1
CO4	3	3	3	2	3	2	-	1	-	1	2	2	-	-	1
AVG	3	2.8	2.5	2.3	2.5	2	1	1	1	1	2	2			1.3

Weightage Values: 3 = Strongly matched, 2 = Moderately matched, 1 = Weakly matched, (-) = Notmatched.

Stream: ECE

Subject Name: MinorProject-II

Subject Code: PR691

Contact hour: 2P

Total contact hour- 20

Credits: 1

Prerequisite: Course completed up to 5th semester in UG ECE

Course Objective:

Prepare students with foundation knowledge in a project domain through surveying, designing, implementing, observing and reporting.

Methodology:

1. Thinking: Discussion on innovative idea.
2. Exploring: Survey of recent research.
3. Implementing: Project guidance to basic prototype implementation.
4. Documenting: Guidance on reporting and conference paper writing.
5. Each Minor Project-II group should submit the following under their semester project report submission with topics not limited to,

Title, certificates, declaration by student, acknowledgement, Table of Contents, abstract, keywords, Introduction, Literature Survey, System Analysis (if applicable), System Design (if applicable), Coding, Testing (if applicable), Conclusion, Future Scope of work), reference

Course outcome:

Sem. No.	Course Title (Code)	CO Codes	Course Outcomes
			On completion of the course students will be able to
6 th	Minor Project-II(PR691)	CO.PR691.1	Apply the knowledge acquired through survey of recent research to set the project goal.
		CO.PR691.2	Distinguish the way of implementation of prototype
		CO.PR691.3	Identify the fault issue through various case study
		CO.PR691.4	Implement the prototype using modern tools
		CO.PR691.5	Demonstrate the project design to share the idea through conference/workshop/seminar etc.

CO-PO-PSO MAPPING:

COs\POs	PO 1	PO 2	PO 3	PO 4	PO 5	PO6	PO 7	PO 8	PO 9	PO10	PO1 1	PO1 2	PSO 1	PSO 2	PSO 3
CO1	3	3	3	2	1	1	3		1	1		3	2	3	
CO2	3	3	3	3	3			3	3		2	3	3	3	2
CO3	2		3	3	2	2	3	3	2	2		3	3	2	1
CO4	1	3	3	2	3		3	2	3		2	3	3	3	3
CO5	3		2	3	3	2		3	3	2		3	3	3	2
AVG	2.4	3	2.8	2.6	2.4	1.666667	3	2.75	2.4	1.666667	2	3	2.8	2.8	2

Stream: ECE

Subject Name: Skill Development VI: Soft Skill & Aptitude-III

Subject Code: PR692

Contact hour:1P

Total contact hour- 10

Credits: 0.5

Prerequisite: Course completed up to 5th semester in UG ECE

Objective:

Business Communication: To improve Communications skills, current English usage, debates, language games, situational dialogues, precis writing, essay writing, presentations.

Presentation Skills: To prepare for effective presentations, presentation for small groups and large groups, marketing and business presentations.

Business Correspondence: To explore the hidden potential of clear writing by identifying misused words, applications and requests, positive and negative responses to requests, routine messages, memos, report writing, organizing meetings, preparation of agenda and minutes, business etiquette, telephone etiquette, e-mail etiquette.

Benefits from the Training: To unveil the ability to communicate clearly and concisely as an advantage to a promising manager. The students will soon realize that fluency and command over speaking and writing gives them an edge while interacting with people at all levels.

Behavioral Skills: to identify an array of skills related to personal growth for efficient functioning constitutes the training. Students are made to realize their strengths and weaknesses so that they are able to grasp the true essence of development. They are made to take part in role plays, games, and puzzles that demonstrate the attributes needed for assertiveness, interpersonal relationships, negotiations, time and goal management, leadership skills, and conflict management.

Course outcome:

Sem. No.	Course Title (Code)	CO Codes	Course Outcomes
			On completion of the course students will be able to
6 th	Skill Development VI: Soft Skill & Aptitude-III (PR692)	CO1	Activate teamwork through learning to connect and work with others to achieve goal for a set task
		CO2	Build responsibility for one's self, learning self-reliance and independence.
		CO3	Communicate and demonstrate with clear briefing and listening skills, not being afraid to ask for help and support when necessary

		CO4	Construct emotional maturity and emotional health by learning to handle emotions including tolerance and behavioural responses, building positive friendships and bonding with peers and classmates, learning to show understanding and to demonstrate respect for the opinions, personal space and beliefs of others
		CO5	Explore Leadership quality by assessing the requirements of a task, identifying the strengths within the team, utilising the diverse skills of the group to achieve the set objective, awareness of risk/safety
		CO6	Grow confidence and enthusiasm for learning by developing self-motivation, raised aspirations and belief in one's own abilities, defining and committing to achieving one's goals

CO-PO-PSO MAPPING:

Sem. No.	Course Title (Code)	CO Codes	Program Outcomes (POs)														
			PO1	PO2	PO3	PO4	PO5	PO6	PO7	PO8	PO9	PO10	PO11	PO12	PSO1	PSO2	PSO3
6 th	Skill Development VI: Soft Skill & Aptitude-III (PR692)	CO1	3	3	3	2	1	1	3		1	1		3	2	3	
		CO2	3	3	3	3	3			3	3		2	3	3	3	2
		CO3	3		2	3	3	2		3	3	2		3	3	3	2
		CO4	2		3	3	2	2	3	3	2	2		3	3	2	1
		CO5	1	3	3	2	3		3	2	3		2	3	3	3	3
		CO6		2	3	3	3	2	3	3	3			3	3		2

COs/POs	PO1	PO2	PO3	PO4	PO5	PO6	PO7	PO8	PO9	PO10	PO11	PO12	PSO1	PSO2	PSO3
CO1	3	3	3	2	1	1	3		1	1		3	2	3	
CO2	3	3	3	3	3			3	3		2	3	3	3	2
CO3	3		2	3	3	2		3	3	2		3	3	3	2
CO4	2		3	3	2	2	3	3	2	2		3	3	2	1
CO5	1	3	3	2	3		3	2	3		2	3	3	3	3
CO6		2	3	3	3	2	3	3	3			3	3		2
AVG	2.4	2.75	2.83	2.67	2.5	1.75	3	2.8	2.5	1.67	2	3	2.83	2.8	2

CourseName: Intellectual Property Right

CourseCode: MC601

Contact: 2:0:0

Total Contact Hours: 24

Credit: 0

Prerequisite: None

Course Outcomes:

Graduates of the ECE program will be able to:

- CO1:** Explain fundamental aspects of Intellectual property Right to students
- CO2:** Apply knowledge on patents, patent regime in India and abroad and registration aspects
- CO3:** Disseminate knowledge on copyrights and its related rights and registration aspects
- CO4:** Disseminate knowledge on trademarks and registration aspects
- CO5:** Understand knowledge on Design, Geographical Indication (GI), Plant Variety and Layout Design Protection and their registration aspects
- CO6:** Analyze current trends in IPR and Govt. steps in fostering IPR

Course Content

Module 1:

4L

Overview of the IPR: Introduction and the need for intellectual property right (IPR) - Kinds of Intellectual Property Rights: Patent, Copyright, Trade Mark, Design, Geographical Indication, Plant Varieties and Layout Design – Genetic Resources and Traditional Knowledge – Trade Secret - IPR in India: Genesis and development – IPR in abroad - International organizations, agencies and treaties,

Module 2:

4L

Patents- Trips Definition, kind of inventions protected by patent-Patentable and Non patentable inventions. Elements of Patentability: Novelty , Non Obviousness (Inventive Steps), Legal requirements for patents — Granting of patent - Rights of a patent-exclusive right. Patent application process: Searching a patent- Drawing of a patent- Filing of a patent- Types of patent applications- Parent document: specification and Claims.

Registration Procedure, Rights and Duties of Patentee, Restoration of lapsed Patents, Surrender and Revocation of Patents, Infringement, Remedies & Penalties

Module 3:

4L

Trademarks- Concept of Trademarks - Different kinds of marks (brand names, logos, signatures, symbols, well known marks, certification marks and service marks) - Non Registrable Trademarks - Registration of Trademarks - Rights of holder and assignment and licensing of marks - Infringement, Remedies & Penalties - trademark registration processes.

Module 4:

4L

Copyrights-

Right and protection covered by copyright - Law of copy rights: Fundamental of copyright law. originality of material, rights of reproduction, right to perform the work publicly, copy right ownership issues, obtaining copy right registration, notice of copy right. International copy right law. Infringement of Copyright under Copyright Act

The Role and Liabilities of IPRs in India - Cyberlaw issues: Criminal law. data safety, online privacy.

Health privacy, Freedom of expression and human rights, net neutrality, national security.

Module 5:

4L

Geographical Indication of Goods: Types, why and how GI need protection and GI laws. Indian GI Act. Industrial Designs: protection. Kind of protection provided by industrial designs. Integrated Circuits

Module 6:

4L

India's New National IPR Policy, 2016 - Govt. of India steps towards promoting IPR - Govt. Schemes IPR

- Career Opportunities in IP - IPR in current scenario with case studies

Textbook:

1. Fundamentals of IP for Engineers: K. Bansal & P. Bansal
2. Nithyananda, K.V. (2019). Intellectual Property Rights: Protection and Management. India, IN: Cengage Learning India Private Limited.
3. Neeraj, P., & Khusdeep, D. (2014). Intellectual Property Rights. India, IN: PHI Learning Private Limited.

Referencebook:

1. Ahuja, VK.(2017).LawrelatingtoIntellectualPropertyRights.India,IN:LexisNexis.

CO-PO Mapping:

CO	PO1	PO2	PO3	PO4	PO5	PO6	PO7	PO8	PO9	PO10	PO11	PO12
CO1	3	-	1	2	3	-	-	2	-	2	3	3
CO2	3	1	-	1	-	-	1		1	-	3	2
CO3	3		1	2	3	-		2		2	2	3
CO4	3	1	-	1	-	-	1	-	1		3	3
CO5	3	-	2	-	2	3	-	-	-	2	3	2
CO6	3	2		1	-	-	-	2	2	-	2	3

Weightage Values: 3 = Strongly matched, 2 = Moderately matched, 1 = Weakly matched, (-) = Notmatched.

Curriculum for B.Tech**Under Autonomy****Electronics & Communication Engineering****(Effective From 2021-22 admission Batch)****L–Lecture; T-Tutorial; P-Practical [1L=1Cr, 1T=1Cr, 1P=0.5Cr]****4th Year 1st Semester: 7th Semester**

Sl.No	Course Code	Paper Code	Theory	Contact Hours				Credits/ Unit
				L	T	P	Total	
A.THEORY								
1	PE	EC701	Professional Elective-IV A: Internet of Things B: Artificial Intelligence C: Digital Control System D: Cloud Computing (AWS)	3	0	0	3	3
2	PE	EC702	Professional Elective-V A: Biomedical Electronics & Imaging B: Introduction to EDA tool C: Radar & Missile Communication D: Introduction to MEMS	3	0	0	3	3
4	OE	EC703	Open Elective-III A: Data Science B: Machine Learning C: Cyber Security & Cryptography	3	0	0	3	3

			D:AdvancedBioSignalProcessing E:Mixedsignal Design					
B.PRACTICAL								
5	PE	EC791	Professional Elective-IV lab A:InternetofThingsLab B: Artificial Intelligence Lab C:DigitalControlSystemLab D:CloudComputing(AWS)Lab	0	0	0	3	1.5
6	OE	EC793	Open Elective-III Lab A:DataScienceLab B:MachineLearningLab C: Cyber Security & Cryptography Lab D:AdvancedBioSignalProcessingLab E:Mixedsignal Design Lab	0	0	3	3	1.5
7	PROJECT	PR791	Major Project-I	0	0	0	4	2
8	PROJECT	PR792	Skill Development VII:Seminar&Group Discussion	0	0	1	1	0.5
9	PROJECT	PR793	IndustrialTraining/Internship	0	0	0	0	1
C.MANDATORYACTIVITIES/COURSES								
10	MC	MC701	Entrepreneurship&InnovationSkill	2	0	0	2	0

TOTAL CREDIT WITHOUT MOOC COURSES								15.5
D.MOOC COURSES**								
11	MOOC COURSES	HM701	MOOC COURSE-VI	3	1	0	4	4
TOTAL CREDIT WITH MOOC COURSES								19.5

***Collective Data from 3rd to 6th Semester (Summer/Winter Training during Semester Break & Internship should be done after 5th Semester or 6th Semester). All related certificates to be collected by the training/internship coordinator(s)**

****MOOC COURSES for HONOURS/MINOR Degree are Program specific and to be taken from MOOC BASKET**

Course Name: Internet of Things

Course Code: EC701A

Contacts:3:0:0

Total Contact Hours: 36

Credits:3

Prerequisite: Sensors, Actuators, Microcontroller, Computer Networks

Course Objectives: The purpose of this course is to gather knowledge about IoT, its architecture, different software and hardware components of IoT. Finally, students will apply such knowledge to design some hands-on models showcasing different IoT applications.

Course Outcomes:

Graduates of the ECE program will be able to

CO1: understand Internet of Things and its hardware and software components

CO2: interface I/O devices, sensors & communication modules

CO3: remotely monitor data and control devices

CO4: develop real-life IoT based projects

Course Content

Module 1: Introduction to IoT: Architectural Overview, IoT Enablers, IoT Applications, Sensing, Actuation, Basics of Networking, M2M and IoT Technology Fundamentals- Devices and Gateways, Data management, Idea of Cloud, Edge and Fog computing, Role of Cloud in IoT, Services offered by Cloud.

10L

Module 2: Elements of IoT: Hardware Components- Arduino, Raspberry Pi development board, Communication, Sensing, Actuation, I/O interfaces. Software Components- Programming API's (using Embedded C/Python/Node.js) for Communication and Network Protocols- RFID, ZigBee, Bluetooth, BLE, MQTT, CoAP, TCP/IP, UDP

10L

Department of Electronics & Communication Engineering

Module3: It Application Development: Solution framework for IoT Applications- Implementation of Device integration, Data acquisition and integration, Device data storage- Unstructured data storage on cloud/local server, Authentication, authorization of devices. Use of AI and ML in IoT

10L

Module 4: IoT Case Studies ‘case studies and mini projects based on Industrial Automation, Transportation, Agriculture, Healthcare, Home Automation.

6L

Textbooks and Reference Books:

1. Introduction to IoT by Sudip Misra, Anandarup Mukherjee, Arijit Roy , 1st Edition Cambridge University Press.
2. Vijay Madiseti, Arshdeep Bahga, Internet of Things, “A Hands on Approach”, University Press
3. Raj Kamal, “Internet of Things: Architecture and Design”, McGraw Hill
4. Pethuru Raj and Anupama C. Raman, “The Internet of Things: Enabling Technologies, Platforms, and Use Cases”, CRC Press
5. Jeeva Jose, “Internet of Things”, Khanna Publishing House, Delhi
6. Adrian McEwen, “Designing the Internet of Things”, Wiley
7. Cuno Pfister, “Getting Started with the Internet of Things”, OReilly Media
8. Dr. SRN Reddy, Rachit Thukral and Manasi Mishra, “Introduction to Internet of Things: A Practical Approach”, ETILabs

CO-PO Mapping:

CO	PO1	PO2	PO3	PO4	PO5	PO6	PO7	PO8	PO9	PO10	PO11	PO12	PSO1	PSO2	PSO3
CO1	2	2	2	2	3	2	1	1	2	2	3	3	2	3	3
CO2	2	3	3	3	3	1	1	1	2	2	3	3	2	3	3
CO3	3	3	2	3	3	2	2	2	3	3	3	3	3	3	3
CO4	3	3	2	2	2	1	1	1	1	1	2	3	1	2	3
AVG	2.5	2.8	2.3	2.5	2.8	1.5	1.3	1.3	2	2	2.8	3	2	2.8	3

Weightage Values: 3=Strongly matched, 2=Moderately matched, 1=Weakly matched, (-)=Not matched.

Course Name: Artificial Intelligence

Course Code: EC701B

Contacts:3:0:0

Total Contact Hours: 36

Credits:3

Prerequisites:

- Strong knowledge of mathematics
- Good command over programming languages
- Good Analytical Skills
- Ability to understand complex algorithms

Course outcome:

Graduates of the ECE program will be able to

CO-1: Understand the concept of AI .

CO-2: Illustrate searching algorithms.

CO-3: Analyze the representation of knowledge.

CO-4: Demonstrate the learning methods.

Module-I [2L]

Introduction:

What is AI, Agents and environment, concept of rationality, nature of environment and structure of agents.

Module-I

[8L]

Searching and Problem Solving:

Well defined problems and solutions, formulating problems, 8 puzzle problem, Tower of Hanoi, Data driven and goal driven search, Breadth-first search, Depth first search, Bidirectional search, Hill climbing, simulated annealing.

Module-III [10L]

Knowledge Representation and Reasoning: Knowledge based agents, The Wumpus world, Logic, Propositional logic, first order predicate logic (FOPL), Rule of inference, Forward and Backward chaining, Algorithms for planning as State-Space search, Planning graphs, Bayes' rule, and Bayesian Networks.

Module-IV [13L]

Learning: Supervised learning, learning decision trees, Evaluating the best hypothesis, the theory of learning, Neural Networks (Network structures, Single layer feed-forward neural network, Multilayer feed-forward neural network, learning weights), Nonparametric model, Ensemble learning, learning with relevance information, learning with complete data, learning with hidden variables, passive and active reinforcement learning, policy search.

Module-V [3L]

Natural Language Processing: Language models, Text classification, Information retrieval, Information extraction.

TextBooks:

1. Artificial Intelligence: A Modern Approach, Russell & Norvig, Prentice Hall.
3. Artificial Intelligence, Elaine Rich and Kevin Knight, TMH.

CO-PO Mapping:

	PO1	PO2	PO3	PO4	PO5	PO6	PO7	PO8	PO9	PO10	PO11	PO12	PSO1	PSO2	PSO3
CO1	3	3	3	3	2		2		3	-	-	3	3	2	2
CO2	3	3	3	3	2	2	2		3	-	2	3	3	2	2
CO3	3	2	3	2	2	-	2		3	2	-	3	1	2	2
CO4	3	3	3	3	2	-	2	2	3	-	-	3	3	2	1
CO5	2	3	2	3	2	-	2		3	-	-	3	3	1	1
AVG	2.8	2.8	2.8	2.8	2	2	2	2	3	2	2	3	2.6	1.8	1.6

Weightage Values: 3 = Strongly matched, 2 = Moderately matched, 1 = Weakly matched, (-) = Notmatched.

CourseName:DigitalControlSystem

CourseCode:EC701C

Contacts: 3:0:0

TotalContactHours:36

Credit:3

Prerequisite: Knowledge about Basic Control System

CourseOutcomes:

Graduates of the ECE program will be able to

CO1: Obtain an overview on Digital Control System and Modelling of Systems in sampled domain.

CO2: Design of any system in digital domain and analysis its stability.

CO3: Obtain concept of Advanced Digital Control System Design and application of its in industry.

CO4: Obtain the concept of Digital Stability of the system.

CourseContent

Module 1: Introduction: Control System Terminology, Computer-Based Control: History and Trends, Control Theory: History and Trends, An Overview of the Classical Approach to Analog Controller Design, Review: System modelling, Review: Actual and desired dynamic response. Review: Feedback control, Review: Frequency response.

[5L]

Module 2: Discrete-Time Systems: Difference equations, z-transform, z-transform solution of difference equations, Time response of discrete-time systems, Frequency response of discrete-time systems, The sampling theorem

[4]L

Department of Electronics & Communication Engineering

Module 3: Modelling Digital Control Systems: ADC model, DAC model, Transfer function of aZOH, Transfer function of DAC, analog system, and ADC combination, Systems with transportlag, Theclosed-looptransferfunction, Steady-stateerroranderrorconstants.

[6L]

Module4:DigitalControlSystemDesign: Digitalimplementationofanalogcontrollers, D i r e c t z- plane root locus design Loop shaping (frequency response) design, OptimalControl, Optimallinearquadraticregulatoranddesign, Kalmanfilterdesign, LQGoptimalcontrol.

[5L]

Module5:StabilityAnalysis: MappingbetweentheS-PlaneandtheZ-Plane–Primarystripsand ComplementaryStrips–Constant,frequencyloci, Constantdampinggratioloci, StabilityAnalysisof closed loop systems in the Z-Plane. Jury stability test – Stability Analysis by use of theBilinearTransformationandRouthStability criterion.

[5L]

Module6:Design ofdiscrete time control system by conventional methods: Transientand steady, State response Analysis, Design based on the frequency response method, BilinearTransformation and Design procedure in the w-plane, Lead, Lag and Lead-Lag compensators anddigitalPIDcontrollers.

[5L]

Module7: State feedback controllers and observers Design of state feedback controller throughpole placement, Necessary and sufficient conditions, Ackerman'sState Observers – Full order andReducedorderobservers.

[6L]

Textbooks:

1. Discrete-Time Control Systems – K. Ogata, Pearson Education/PHI, 2nd Edition
- Reference Books:
1. Digital Control Systems, Kou, Oxford University Press, 2nd Edition, 2003.
2. Digital Control and State Variable Methods by M. Gopal, TMH

CO-PO Mapping: PSO 3

CO	PO1	PO2	PO3	PO4	PO5	PO6	PO7	PO8	PO9	PO10	PO11	PO12	PSO1	PSO2	PSO3
CO1	3	1	2	-	-	-	-		3	-	2	1	-	-	3
CO2	-	-	-	-	2	2	1	3	2	-	3	2	-	-	-
CO3	2	2	2	-	2	3	-	2	3	-	2	3	-	-	-
CO4	3	-	3	-	1	3	2	3	2	-	2	3	-	-	1
AVG	2.7	1.5	2.3		1.7	2.7	1.5	2.7	2.5		2.3	2.3			2.0

Weightage Values: 3=Strongly matched, 2=Moderately matched, 1=Weakly matched, (-)=Not matched.

PaperCode:EC701D

PaperName:CloudComputing

Contact:3:0:0

Total Contact Hours:36

Credits: 3

Prerequisites:

- ShouldhavethebasicknowledgeofOperatingSystemsandVirtualizationTechnologies
- ShouldbeawareofthefundamentalconceptsofNetworking
- Shouldhaveknowledgeofheterogeneousssystemsandresource management.

CourseOutcome:

CO1:Articulatethebusinessmodelconcepts,architectureandinfrastructureofcloudcomputing,includingcloud servicemodelsand deploymentmodels.

CO2:ApplyanddesignsuitableVirtualizationconcept,CloudResourceManagement,anddesignschedulingalgorithms.

CO3:ExploresomeimportantcloudcomputingdrivencommercialssystemssuchasGoogleApps,MicrosoftAzure and Amazon Web Servicesand otherbusinesses cloudapplications.

CO4:Analyzethecore issuesofcloudcomputingsuchas security,privacy,interoperability,andits impactoncloudapplication.

Module1:DefinitionofCloudComputinganditsBasics

[9L]

1. Definition of Cloud Computing: Defining a Cloud, Cloud Types – NIST model, Cloud Cubemodel, Deployment models (Public, Private, Hybrid and Community Clouds), Service models –Infrastructure as a Service, Platform as a Service, Software as a Service with examples of services/serviceproviders,CloudReferencemodel,CharacteristicsofCloudComputing–ashiftinparadigmBenefitsand advantagesof CloudComputing[4]
2. Cloud Architecture: Cloud Infrastructure, Architecture of each component, Virtualization versusTraditionalApproach,Virtualization ModelforCloudComputing.[2]
3. ServicesandApplicationsbyType[3]

Department of Electronics & Communication Engineering

IaaS–Basicconcept, Workload, partitioning of virtual private server instances, Pods, aggregations, silos

PaaS–Basicconcept, tools and development environment with examples

SaaS-

Basicconcept and characteristics, OpenSaaS and SOA, examples of SaaS platform Identity as a Service (IDaaS) Compliance as a Service (CaaS)

Module 2: Use of Platforms in Cloud Computing

[6L]

1. Concept of Abstraction and Virtualization [2]

Virtualization technologies: Types of virtualizations, Load Balancing and Virtualization: Basic Concepts, Network resources for load balancing; Classification of Virtualization Environment: Scheduling-based Environment, Load-Distribution-Based Environment, Energy Aware-Based Environment, Operational-Based Environment, Distributed Pattern-Based Environment, Transactional-Based Environment

2. Mention of The Google Cloud as an example of use of load balancing Hypervisors: Virtual machine technology and types, VMware vSphere Machine imaging (including mention of Open Virtualization Format – OVF) [2]

Porting of applications in the Cloud: The simple Cloud API and AppZero Virtual Application appliance

3. Concept of Platform as a Service [2]

Definition of services, Distinction between SaaS, and PaaS (knowledge of Salesforce.com and Force.com), Application development. Use of PaaS Application frameworks

Module3:CloudServiceModels**[6L]**

1. UseofGoogleWebServices[2L]

Discussion of Google Applications Portfolio – Indexed search, Dark Web, Aggregationanddisintermediation,Productivityapplicationsandservice,Adwords,GoogleAnalytics,Google Translate, a brief discussion on Google Toolkit (including introduction of GoogleAPIsinbrief),majorfeaturesof GoogleAppEngineservice.

2. UseofAmazonWebServices[2L]

Amazon Web Service components and services: Amazon Elastic Cloud, Amazon SimpleStorage system, Amazon Elastic Block Store, Amazon Simple DB and Relational DatabaseService

3. UseofMicrosoftCloudServices[2L]

Windows Azure platform: Microsoft’s approach, architecture, and main elements, overviewof Windows Azure AppFabric, Content Delivery Network, SQL Azure, and Windows Liveservices

Module4:CloudInfrastructure**[10L]**

Typesofservicesrequiredinimplementation–Consulting,Configuration,CustomizationandSupport

1. CloudManagement[3L]

An overview of the features of network management systems and a brief introduction ofrelatedproductsfromlargecloudvendors,Monitoringofanentirecloudcomputingdeployment stack – an overview with mention of some products, Lifecycle management ofcloudservices(six stages oflifecycle)

2. LiveMigrationofVirtualMachines:[2L]

Need of Live Migration of Virtual Machine, A Designing Process of Live Migration, andSecurityIssuesduring livemigration

3. ConceptsofCloudSecurity [3L]

Infrastructure Security, Infrastructure Security: The Network Level, The Host Level, TheApplication Level, DataSecurityand Storage, Aspectsof Data Security,Data SecurityMitigationProviderDataandItsSecurity, Identityand AccessManagement

4. AuditingandComplianceinCloudEnvironment: [2L]

Data Security in Cloud Computing Environment, Need for Auditing in Cloud ComputingEnvironment, Third Party Service Provider, Cloud Auditing Outsourcing Lifecycle Phases,AuditingClassification.

Module5:ConceptsofServicesandApplications**[5L]**

1. Service Oriented Architecture: Basic concepts of message-based transactions, Protocolstack foran

SOA architecture, Event-driven SOA, Enterprise Service Bus, Service catalogs[1]

2. Applications in the Cloud: Concepts of cloud transactions, functionality mapping, Application attributes, Cloud service attributes, System abstraction and Cloud Bursting, Applications and Cloud APIs[2]
3. Cloud-based Storage: Cloud storage definition – Manned and Unmanned.[1]
4. Webmail Services: Cloud mail services including Google Gmail, Mail2Web, Windows Live Hotmail, Yahoo mail, concepts of Syndication services[1]

Textbooks:

1. Mastering Cloud Computing by Rajkumar Buyya, Christian Vecchiola, S. Thamarai Selvi, McGraw Hill Education (India) Private Limited, 2013
2. Fundamentals of Cloud Computing by P.K. Pattnaik, S. Pal, M.R. Kabat, Vikas Publications, 2014.

Reference Books:

1. Cloud Computing Bible by Barrie Sosinsky, Wiley India Pvt. Ltd, 2013
2. Cloud computing: A practical approach, Anthony T. Velte, Tata McGraw-Hill

CO-PO Mapping:

	PO 1	PO 2	PO 3	PO 4	PO 5	PO 6	PO 7	PO 8	PO 9	PO 10	PO 11	PO 12	PSO 1	PSO 2	PSO 3
CO 1	3	3	3	2	2	-	-	-	-	-	3	3	3	3	3
CO 2	3	3	3	2	1	-	1	-	-	-	3	3	3	3	3
CO 3	3	3	3	2	2	2	-	-	2	-	3	3	2	3	2
CO 4	3	3	3	2	-	-	-	2	1	-	3	3	2	2	2
AVG	3	3	3	2	1.7	2	1	2	1.5		3	3	2.5	2.8	2.5

Weightage Values: 3=Strongly matched, 2=Moderately matched, 1=Weakly matched, (-)=Not matched.

Course Name: Biomedical Electronics and Imaging

Course Code: EC702A

Contacts: 3:0:0

Total Contact Hours: 36

Credit: 3

Pre-requisite:

Concepts in Analog Electronics (Studied in Basic Electronics Engineering). Fundamental concepts on mathematics. Concepts in Digital Signal Processing.

Course Outcomes:

Graduates of the ECE program will be able to

CO1: Explain Bioelectric signals, human physiological system, and different types of transducers

CO2: Understand different types of medical measurement systems.

CO3: Able to understand different types of biomedical signal acquisition electrodes and different types of signal amplification techniques and able to design the amplifiers.

CO4: Able to examine the data handling, filtering techniques of bio-medical signals and able to analyze of time and frequency domain.

CO5: Able to understand medical imaging techniques and implement differential algorithms to feature extract the signals.

Course Content:

Module I: Introduction of Medical Electronics:

[6L]

Origins of Bioelectric signals, Electrocardiogram (ECG), Electromyogram (EMG), Recording Electrodes - Silver-silver Electrodes, Electrodes for ECG, EEG and EMG, Physiological Transducers - Pressure Transducers, Temperature sensors, Pulse sensors; Sources of bioelectric potential, resting potential, action potential, propagation of action potentials in nerves, Artificial heart (Basic Idea)

Department of Electronics & Communication Engineering

ModuleII:MedicalMeasurementsystems:

[8L]

Specificationsofinstruments,static&dynamiccharacteristics,classificationoferrors,statistical analysis. Introduction to reliability, accuracy, fidelity, speed of response, Impedance,andcurrentdistribution,bipolarandtetrapolarcircuits,skinimpedance,galvanicskinresponse measurement,totalbodyimpedance,cardiacoutput,neuralactivity,respiratoryactivity,impedanceplethysmography-resistanceandcapacitancetype.

Brain-computerinterface,Neuralimplants,RetinalImplants

ModuleIII:Bio-amplifierandBio-potentialelectrodes

[8L]

Need forbio-amplifier-singleended bio-amplifier,differential bio-amplifier–rightleg drivenECGamplifier.Band passes filtering, isolation amplifiers –transformer and optical isolation - isolatedDC amplifier and AC carrier amplifier. Types of electrodes -surface, needle and micro electrodesandtheir equivalent circuits.Recording problems-measurement with two electrodes.

Patchclamp amplifier -theelectronicsoflownoise currentdetection

ModuleIV:MedicalSignalProcessing

[8L]

Biomedical signal origin & dynamics (ECG), Biomedical signal origin & dynamics (EEG, EMGetc.),Filtering for Removal of artifacts Illustrations of problem with case studies MorphologicalAnalysis of ECG Correlation coefficient The Minimum phase correspondent and Signal Length.

EMG Signal and its Processing: EMG Signal Filtering & Noise Removal, Detection of Flexion andextension.

ModuleV:Medical ImagingTechniques

[6L]

CTscan,ultrasound,NMRandPET,Implementationofalgorithmscoveredinthecoursetocharacterizethesesignals.

Computeraidediagnosis(CAD)andadvanceddiagnosticimageprocessing

ReferenceBooks:

WaveletsandTimefrequencymethodsforBiomedicalsignalProcessing-M.Akay,IEEE Press,DigitalProcessingofspeechsignals-L.Rabinar,Pearson

EducationBiomedicalInstrumentationandMeasurements-Cromwell,WeibellandPfeiffer, PHI

CO-PO-PSO MAPPING

CO	PO1	PO2	PO3	PO4	PO5	PO6	PO7	PO8	PO9	P10	P11	P12	PSO1	PSO2	PSO3
CO1	2	3	2	-	2	1	1	1	1	1	1	2	3	2	2
CO2	3	2	2	-	-	-	-	-	2	2	-	1	3	3	2
CO3	3	2	1	2	1	1	2	-	2	1	2	-	3	2	2
CO4	3	1	-	-	1	2	-	2	1	2	-	1	3	2	2
CO5	1	1	3	2	1	1	-	-	2	1	-	2	2	2	2
AVG	2.6	1.8	2	2	1.3	1	2		1.8	1	2	1	2.8	2.2	2

Weightage Values:3=Stronglymatched,2=Moderatelymatched,1=Weaklymatched,(-)=Notmatched.

Course Name: Introduction to EDA Tools

Course Code: EC702B

Contact: 3:0:0

Total Contact Hours: 36

Credits: 3

Prerequisites: Basic Concepts of Digital Electronics

Course Outcomes:

CO1: Able to originate and optimize model of IC with help of high level and logic level synthesis in digital domain

CO2: Able to build and analyse VLSI circuits in physical design phase with the help of partitioning, floorplanning, placement and routing

CO3: Able to elaborate and estimate the delay of a IC in design phase with the help of logic effort, electrical effort, Elmore delay model, Directed Acyclic Graph (DAG).

CO4: Able to predict fault in digital IC with the help of different fault models and D-algorithm and develop test pattern with the help of ATPG algorithm for BIST

CO5: Able to design system with the help of Verilog HDL for the application in combinational and sequential domain .

Course Content:

Module I: Introduction to Synthesis

[6L]

Introduction – Electronic Design Automation for Integrated Circuits; High level synthesis – Control and Data flow graph, scheduling, allocation & binding, Logic synthesis -gate level optimization, technology mapping, BDD, ROBDD

Module II: Physical Design Automation

[10L]

Partitioning -level of partitioning , partitioning algorithm ; Floorplanning – input ,output & objectives with example, cost estimation of floorplan, dead space, slicing & non-slicing floorplan, hierarchical floorplan, polar graph, Floorplanning algorithm, pin assignment; Placement – objectives , placement problem at different levels (system , board & chip), estimation of wirelength (multi terminal) , placement algorithm – simulation based; Routing – grid, global & detailed routing, Mazerunning algorithm

, Lee's algorithm, line search algorithm, Steinertree algorithm.

Module III: Timing Analysis**[4L]**

Slew balancing , transistor equivalency , design of basic gates for equal rise and fall time , intrinsic delay, parasitic delay, logical effort, electrical effort, Interconnect delay - Elmore Delay Model, Static Timing Analysis using Directed Acyclic Graph (DAG), false path, timing driven routing

Module IV: Testing of VLSI Circuit**[8L]**

Types of Faults in ASIC Design, Fault Models, Faults detection - Rauth's Algorithm /

D-Algorithm; Fault Simulation - Serial, Parallel, Deductive & Concurrent Fault Simulation.

Test pattern Generation - Boundary Scan, Built-In-Self-

Test (BIST), Automatic Test Pattern Generation (ATPG), Design for Testability (DFT).

Module V: Design using Verilog**[8L]**

Operators, data types, numbers, logic, Modeling using Verilog, statements (assignment, wait, control), testbench, FSM, design example – combinational and sequential.

Textbooks:

1. Algorithm for VLSI Physical Design Automation, Naveed A. Sherwani
2. VLSI Design and EDA Tools, Angsuman Sarkar, Swapnadip De, C.K. Sarkar, Scitech
3. VLSI Design, Debaprasad Das, Oxford
4. Digital Integrated Circuit, J.M. Rabaey, Chandrakasan, Nicolic, Pearson Education.
5. CMOS Digital Integrated Circuits Analysis and Design, S.M. Kang & Y. Leblebici, TMH.

Reference Books:

1. G. De Micheli. Synthesis and optimization of digital circuits,
2. S. Palnitkar, Verilog HDL: A Guide to Digital Design and Synthesis, Prentice Hall,

CO-PO-PSO MAPPING

COs	PO1	PO2	PO3	PO4	PO5	PO6	PO7	PO8	PO9	PO10	PO11	PO12			
CO1	2	2	3	1	2	1	-	1	2	2	2	3	-	-	-
CO2	3	3	3	3	2	1	-	1	2	2	3	3	-	-	-
CO3	3	3	3	2	2	-	1	1	2	2	3	3	-	-	-
CO4	3	3	3	1	2	1	1	1	2	2	3	3	-	-	-
CO5	3	3	3	2	3	1	1	1	2	2	3	2	-	-	-
AVG	2.8	2.8	3	1.8	2.2	1	1	1	2	2	2.8	2.8			

Weightage Values:3=Stronglymatched,2=Moderatelymatched,1=Weaklymatched,(-)=Notmatched

CourseName:Radar&MissileCommunication

CourseCode:EC702C

Contact:3:0:0

TotalContactHours:36

Credits:3

Prerequisite: Fundamental knowledge of electronics, measuring instruments, electromagnetic, antenna and wave propagation is required. Communication Systems.

The main objective of the course is to provide knowledge to the students on the fundamental concepts of RADAR, types, and measurements. The students will also learn about missile system, classification of missiles, aerodynamics of missiles, subsystems, and missile trajectory.

CourseOutcomes:

Graduates of the ECE program will be able to

At the end of the course the students should be able to

CO1 Understand the Fundamentals of Radar and Different types of Radar and their working

CO2: Analyze the Radar signal measurement and detection of target in clutter

CO3: Understand basics of missile design and the engineering aspects of missile integration.

CO4: Demonstrate the concept of guided missiles and aerodynamics of missiles.

CO5: Illustrate the various sub-systems used in missiles

Course Content:

Module–I:Introduction to Radar

[5L]

Historical background, radar terminology, radar band designations, Radar block diagram, radar equation: detection of signals in noise and signal-to-noise ratio, Probabilities of detection & False alarm, integration of radar pulses, radar cross section, distributed targets, Transmitted power, pulse-repetition frequency, antenna parameters & system losses, introduction to radar clutter.

Module–II:Radar Types

[5L]

Pulse radars and CW radars, Advantages of coherent radar, Doppler radar, and MTI: Dopplereffect, delay-line cancellers, blind speeds, staggeredPRFs, Digital filter bank, Moving TargetDetector, limitations of MTI, trackingwith radar, monopoles tracking, conical scan, limitation totrackingaccuracy

Module –III:Radarsignals&clutteranditsapplication: [8L]

Basicradarmeasurement,theoreticalaccuracyofradarmeasurements,Rangeandvelocityambiguities, the ambiguity diagram, Descriptions of l a n d&seaclutter,statisticalmodelsforsurfaceclutter,detectionoftargetsin clutter. Applications: Electronic Warfare: ESM, ECM,ECCM;superresolution, IFM,typesofjammers,

MISSILETECHNOLOGY

Module –IV Introduction to Guided Missiles: [5L]

Classification ofMissiles, Overview ofmissiledesignprocess.Examplesofsystemintegration.Configuration sizingparameters.Conceptualdesignprocess.Examplesofmissionrequirements.Exampleofsensitivityanalysis.

Module –V: Aerodynamics in Missile Design, Development, andSystem Engineering: [6L]

IntroductiontoMissileSystem,InterrelationshipbetweenvariousMissileSub-Systems.Optimizingmissileaerodynamics.Shapesforlowobservables.Configurationlayoutoptions.Selectingflightcontrolalternatives.Wingandtailsizing.Predictingnormalforce,drag,pitchingmoment,stability,flightcontroloffectivenessanddivertmaneuveringalternatives.

Module–VI:FlightPerformanceinMissileDesign,Development,andSystemEngineering :[7L]

Flight envelope limitations. Aerodynamic sizing-equations ofmotion. Accuracy of simplifiedequations of motion. Maximizing missile flight performance. Benefits of flight trajectory shaping.Flightperformancepredictionofboost,climb,cruise,coast,steadydescent,ballistic,maneuvering,divert, andhoming flight.Automatictargetrecognition.

Books:

1. “UnderstandingofRadarSystems”,SimonKingsleyandShaunQuegan,McGrawHill,1993.
2. Introduction to Radar Systemsby Skolnik , McGraw-Hill,2001
3. "MicrowaveandRadarEngineering"byGottapuSasiBhushanaRao,ISBN –9788131799444PearsonEducation2013.
4. “FundamentalsofGuidedMissiles”,byS.R.Mohan.Publisher:DefenceRe-searchand DevelopmentOrganisation.

5. “EstimationandPredictionofBallisticMissileTrajectories”byJeffreyA.Isaac-son,David R. Vaughan.Publisher:RAND(29 May1996)
6. “IntroductiontoModernAlgebraandMatrixTheory”, byO.Schreier,E.Sperner,MartinDavid,MelvinHausner.Publisher:DoverPublications.

CO-PO-PSO MAPPING

COs	PO1	PO2	PO3	PO4	PO5	PO6	PO7	PO8	PO9	PO10	PO11	PO12	PSO1	PSO2	PSO3
CO1	3	3	3	-	1	1	-	-	2	-	-	3	-	-	1
CO2	2	3	-	3	2	-	2	-	-	1	3	3	-	-	
CO3	3	2	3	3	2	2	-	-	2	-	-	2	-	-	1
CO4	3	3	3	2	2	-	2	-	-	3	2	3	-	-	-
CO5	3	3	-	3	3	2	-	-	-	-	-	3	-	-	-
AVG	2.8	2.8	3	2.75	2	1.7	2		2	2	2.5	2.8			1

Weightage Values:3=Stronglymatched,2=Moderatelymatched,1=Weaklymatched,(-)=Notmatched.

Course Name: Introduction to MEMS

CourseCode:EC702D

Contact:3:0:0

TotalContactHours:36

Credits:3

Prerequisites:

The student to whom this course will be offered must have the concept of VLSI and Microelectronics.

CourseOutcomes:

Graduate of the ECE program will be able to:

CO1: Demonstrate the clean room concept

CO2: Implement the Substrate for MEMS

CO3: Conceptualize the deposition and photolithography process thoroughly.

CO4: Fabricate the MEMS devices through bulk micromachining techniques.

CO5: Explain the design, analysis and testing of MEMS.

CourseContent:

Module1: Introduction

6L

Cleanroom Technology

Microelectromechanical System (MEMS) – History, Definitions and Classifications, Market and Application, Materials for MEMS, Significance of MEMS

Module2: Substrate for MEMS

6L

Introduction

Silicon – the base- Silicon as a semiconductor, Surface contamination, Cleaning & etching

Dielectrics- SiliconDioxide(SiO₂), SiliconNitride(Si₃N₄), Lowtemperatureoxidation,Oxideproperties

Module3: Deposition

6L

PhysicalVapourdeposition- Vacuumfundamentals,e-beam evaporation,Thermalevaporation, Sputtering,Moleculerbeamepitaxi(MBE),

ChemicalVapourdeposition-APCVD,PlasmaCVD,MOCVD

Metallization - Differenttypesofmetallization,Uses,FusionBonding

Module4: Photolithography -Patterntansfer

6L

Introductionsequence - Photoresist(PR)forstructuring,PositivePR,NegativePR

DesigningofMasklayoutusingClewinssoftware

PhotolithographyProcess-

Applicationofphotoresistandprebake,Alignment,Exposureandpatternformation,PRdeveloperandPostbake,SomeAdvance dlithographictechniques

Module5:

StructuringMEMS–Micromachining

6L

Introduction

Bulkmicromachining - Wetetching

Isotropicandanisotropic–Impiricalobservations

ConvexandConcavecornerCompensations

Dryetching

Surfacemicromachining- Processes,Hurdles,Lift-offvsEtchback,Etchstoptechnique

BoronEtchStop, ElectrochemicalEtch-Stop,Photo-AssistedElectrochemicalEtchStop(forn-TypeSilicon),EtchStopatThinFilms-Silicon onInsulator

Highspectratiomicromachining(HARM) – LIGA,LaserMicromachining

Module6

MEMSandNanotechnologyenabledsensorapplications

6L

EverydayNanotechnology,Automotiveapplications-anelaboratedstudy,Homeappliances,Aerospace

Environmental monitoring,ProcessEngineering,MedicalDiagnostic

TextBooks:

1. MEMS and Nanotechnology for Gas Sensor – Sunipa Roy, Chandan Kumar Sarkar
2. Microsystem Design, Stephen D. Senturia, Kluwer Academic Publishers, 2001,
3. Fundamentals of Microfabrication, Marc J. Madou, CRC Press LLC, 2002.
4. Chang Liu, “Foundations of MEMS”, Pearson International Edition, 2006

ReferenceBooks:

[1]. Gabriel M. Rebiz, “RF MEMS Theory, Design and Technology”, John Wiley & Sons, 2003 [2]. Charles P. Poole, Frank J. Owens, “Introduction to nanotechnology” John Wiley & Sons, 2003. [3]. Julian W. Gardner, Vijay K. Varadhan, “Microsensors, MEMS and Smart devices”, John Wiley & Sons, 2001.

CO-PO-PSO MAPPING

CO	PO1	PO2	PO3	PO4	PO5	PO6	PO7	PO8	PO9	PO10	PO11	PO12	PSO1	PSO2	PSO3
CO1	2	3	3	2	2	-	2	-	3	1	1	3	-	-	-
CO2	3	3	2	3	2	-	2	-	3	-	-	2	-	1	-
CO3	2	3	3	3	2	-	2	-	3	1	2	3	-	-	-
CO4	3	3	2	2	2	-	2	-	3	-	-	3	-	1	-
CO5	3	3	3	3	2	-	2	-	3	2	2	2	-	1	-

Weightage Values: 3=Strongly matched, 2=Moderately matched, 1=Weakly matched, (-)=Not matched.

CourseName:DataScience

Course Code: EC703A

Contact:3:0:0

TotalContactHours:36

Credits:3

PRE-REQUISITES:IntroductiontoProgramming,Probability

CourseOutcome:

GraduatesoftheECEprogramwillbeableto

CO1: Describethebasicandintermediateconceptsofprobability,statistics,anddistributions.

CO2: AbletoApplyregression,ANOVA,andgoodnessoffittestoconstructmodelandinferconclusion
nsabout population/sample.

CO3: AbletoAnalyzehypothesistoaccept/rejectalternativehypothesisbasedonstatisticalevidence
available.

CO4: AbletolearnProgrammingToolsforDataScience

CO5: Solvereal-worldmachinelearningtasksfromdatatoinference

CourseContent:

Module-I: 10L

IntroductiontoDataScience:

Concept of Data Science, Sample, Population, Measures of Central Tendency: Mean, median,mode, Range, Inter Quartile range, Cumulative frequency distribution, Traits of Big data, WebScraping,Analysisvs Reporting3L

IntroductiontoProgrammingToolsforDataScience

Toolkits using Python: Matplotlib, NumPy, Scikit-learn, NLTK, Panda. 3L

Tabular and Graphical Descriptive Techniques, Bar Charts, Line Charts, Scatter plots, 1L

Working with data: Reading Files, Scraping the Web, Using APIs (Example: Using the Twitter

APIs), Cleaning and Munging, Manipulating Data, Rescaling, Dimensionality Reduction 3L

Module II: Statistics for data science 12L

Measures of Dispersion: Mean, Quartile deviation, Standard Deviation, Variance, Moments, Skewness, Kurtosis, Numerical Problem. 2L

Probability: Dependence and Independence, Conditional Probability, Bayes Theorem, Random Variables, Continuous Distributions, Binomial, Poisson, Normal Distribution, The Central Limit Theorem, Standard error, Numerical Problem 4L

Correlation and Regression: Bivariate Data, Correlation, Covariance, Correlation coefficient, Regression, Numerical Problem 2L

Hypothesis and Inference: Hypothesis Testing, Inference about a population, Confidence Intervals, Theory of Test of significance, z-statistics and z-score, t-statistics, Degrees of Freedom, Type I & Type II error, P-values, Chi-square test, Bayesian Inference, Numerical Problem 8L

Module-III: 10L

Machine Learning :

Overview of Machine learning concepts – Overfitting and train/test splits, Types of Machine learning

– Supervised, Unsupervised, Reinforced learning, Introduction to Bayes Theorem, Linear Regression – model assumptions, regularization (lasso, ridge, elastic net), Classification and Regression algorithms – Naïve Bayes, K-Nearest Neighbors, logistic regression, support vector machines (SVM), decision trees, and random forest, Classification Errors, Analysis of Time Series – Linear Systems Analysis, Nonlinear Dynamics, Rule Induction, Neural Networks – Learning

And Generalization, Overview of Deep Learning. 6L

Module IV: 4L

Case Studies of Data Science Application (Any four)

Weather forecasting, Stock market prediction, Object recognition, Real Time Sentiment Analysis. Image visibility improvement through statistical model.

4L

LIST OF SUGGESTED BOOKS

1. N.G.Das "Statistical Methods", McGraw Hill
2. Joel Grus, "Data Science from Scratch: First Principles with Python", O'Reilly Media
3. Jain V.K., "Data Sciences", Khanna Publishing House, Delhi.
4. Jain V.K., "Big Data and Hadoop", Khanna Publishing House, Delhi.
5. Jeeva Jose, "Machine Learning", Khanna Publishing House, Delhi.
6. Chopra Rajiv, "Machine Learning", Khanna Publishing House, Delhi.
7. Ian Goodfellow, Yoshua Bengio and Aaron Courville, "Deep Learning", MIT Press <http://www.deeplearningbook.org>

CO-PO mapping:

CO	PO1	PO2	PO3	PO4	PO5	PO6	PO7	PO8	PO9	PO10	PO11	PO12	PSO1	PSO2	PSO3
CO1	2	2	3	1	1	1	2	1	2	1	1	1	3	2	2
CO2	3	3	2	3	2	2	1	2	2	2	2	3	3	3	2
CO3	2	3	3	2	1	1	-	1	2	1	1	2	3	2	2
CO4	3	2	2	2	2	2	1	2	2	2	1	3	3	2	2
CO5	2	3	3	2	1	1	-	1	2	1	3	2	2	2	2
AVG	2.8	2.8	3	1.8	1			1	2	1	1	2.4	2.8	2.2	2

Weightage Values: 3=Strongly matched, 2=Moderately matched, 1=Weakly matched, (-)=Not matched

CourseName:MachineLearning

Course Code:EC703B

Contact:3:0:0

Totalcontact hours:36

Credits:3

Courseoutcomes:

GraduatesoftheECEprogramwillbeableto

CO1:Abletodemonstratethelinearandlogisticregressionmodel

CO2:Ableto describethecurseof dimensionality.

CO3:Abletoidentifythemodelofsupervisedlearning.

CO4:Abletoillustratetheartificialneuralnetworktofindthepatternindata.

CO5:Ableto identifythemodel ofunsupervisedlearning.

Prerequisite:

- Knowledgeofbasiccomputerscienceprinciplesandskills
- Familiaritywiththebasicprobabilitytheory
- Familiaritywiththebasiclinearalgebra

Module-I

(Introduction) [1L]

Overviewoftheapplicationofmachinelearning,Conceptoferrorfunctionandoptimization,Conceptofsupervised, unsupervised andreinforcementlearning.

Module-II(Regression) [5L]

Linear regressionmodel withsingle and multiple variables, Gradient descent algorithm, leastsquare

Module-III(Dimensionalityreduction)

[10L]

Conceptofdimension,Curseofdimensionality,LassoandRidgeregressionintoreducedimension,ApplicationofelastinetoverLassoandRidge,Principal component analysis,Lineardiscriminantanalysis,Sammonmapping,Filtermethod,wrappermethod

Module-IV(Classifier)

[16L]

Logistic regression and Linear discriminant functions for binary classification, Naïve Bayes Classifier, K-Nearest Neighbor.

Decision trees: measures of impurity, information gain/entropy reduction, Gini index.

Support Vector Machine: Developing the objective function and the effect of hyper

parameter, concept of Kernel-SVM.

Artificial Neural Network: Compare Biological Neurons and Artificial neurons, Sigmoidal activation function, McCulloch-Pitts model, Feedforward & Feedback network, Single layer perceptron, Implementation of logical AND & OR, Effect of Multilayer perceptron over single layer, Implementation of XOR, Back propagation algorithm, Radial Basis Functions Network, Hebb rule, Importance of training and test accuracy to learn the ANN.

Module-V(Clustering)[4L]

K means algorithm, Hierarchical clustering, Gaussian mixture density estimation, Fuzzy-C-Means, Silhouette and

Dunn cluster validation index.

Textbooks:

- Pattern recognition and machine learning by Christopher M. Bishop, Springer
- Understanding Machine Learning by Shai Shalev-Shwartz and Shai Ben-David, Cambridge University Press
- Pattern Classification by Richard O. Duda, Peter E. Hart & David G. Stork, John Wiley.
- Pattern Recognition by Konstantinos Koutroumbas, Sergios Theodoridis, Elsevier

CO-PO-PSO MAPPING

CO	PO1	PO2	PO3	PO4	PO5	PO6	PO7	PO8	PO9	PO10	PO11	PO12	PSO1	PSO2	PSO3
CO1	2	2	3	2	2							3	1	1	3
CO2	3	3	2	1	3							3	1	1	3
CO3	1	3	3	3	2							3	1	1	3
CO4	3	3	2	2	3							3	1	1	3
CO5	2	3	2	3	1							3	1	1	3
AVG	3	3	3	3	2.6							3	1	1	3

Weightage Values: 3=Strongly matched, 2=Moderately matched, 1=Weakly matched, (-)=Not matched

Course Name: Cyber Security & Cryptography

Course Code: EC703C

Contact: 3:0:0

Total Contact Hours: 36

Credits: 3

Prerequisites

1. Knowledge of Computer Networks and Operating Systems fundamentals
2. Understanding of Discrete Mathematics concepts

Course Outcome(s):

Graduates of the ECE program will be able to

CO1 Acquire fundamental knowledge and compare different cryptographic techniques.

CO2 Develop and design various block cipher and stream cipher models

CO3 Demonstrate the principles of public key cryptosystems, hash functions and digital Signature.

CO4 Analyze varied network security tools and authentication applications

CO5 Develop and apply email security, IP security, web security services and mechanisms

Course Contents Module-1

[7L]

Introduction-Services, Mechanisms, and Attacks, OSI security architecture, Network security mode, Classical Encryption techniques (Symmetric cipher model, substitution techniques, transposition techniques, steganography), Finite Fields and Number Theory: Groups, Rings, Fields, Modular arithmetic, Euclid's algorithm, Polynomial Arithmetic, Prime numbers, Fermat's and Euler's theorem, Testing for primality - The Chinese remainder theorem - Discrete logarithms.

Module-2

[9L]

Data Encryption Standard-

Blockcipher principles, blockcipher modes of operation, Advanced Encryption Standard (AES), Triple DES, Blowfish, RC5 algorithm, Public key cryptography: Principles of public key cryptosystems, The RSA algorithm, Key management - Diffie-Hellman Key exchange, Elliptic curve arithmetic, Elliptic curve cryptography.

Module-3

[6L]

Authentication requirement, Authentication function, MAC, Hash function, Security of hash function and MAC, MD5, SHA, HMAC, CMAC, Digital signature and authentication protocols, DSS, ElGamal, Schnorr.

Module-4

[7L]

Authentication applications, Kerberos, X.509, Internet Firewalls for Trusted System: Roles of Firewalls, Firewall related terminology - Types of Firewalls, Firewall designs principles, SET for E-Commerce Transactions, Intruder, Intrusion detection system, Virus and related threats, Countermeasures, Trusted systems, Practical implementation of cryptography and security.

Module-5

[7L]

E-mail Security: Security Services for E-mail - attacks possible through E-mail, Establishing key privacy, authentication of the source, Message Integrity, Non-repudiation, Pretty Good Privacy, S/MIME, IP Security: Overview of IPsec, IPv4 and IPv6 - Authentication Header, Encapsulation Security Payload (ESP), Internet Key Exchange (Phases of IKE, ISAKMP/IKE Encoding), Web Security: SSL/TLS Basic Protocol, computing the keys, client authentication, PKI as deployed by SSL Attacks fixed in v3, Exportability, Encoding, Secure Electronic Transaction.

Textbooks

- [1] Kahate, A. (2013). Cryptography and network security. Tata McGraw-Hill Education.
- [2] Forouzan, B. A., & Mukhopadhyay, D. (2015). Cryptography and network security. New York, NY: McGraw Hill Education (India) Private Limited.

Reference Books

- [1] Stallings, W. (2006). Cryptography and network security, 4/E. Pearson Education India.
- [2] Daras, N. J., & Rassias, M. T. (Eds.). (2015). Computation, cryptography, and network security (pp. 253-287). Springer.
- [3] Kumar, A., & Bose, S. (2017). Cryptography and network security. Pearson Education India.

CO-PO-PSO MAPPING

CO	PO1	PO2	PO3	PO4	PO5	PO6	PO7	PO8	PO9	PO10	PO11	PO12	PSO1	PSO2	PSO3
CO1	2	2	3	1	3	1	1	1	2	1	1	1	-	-	-
CO2	2	2	3	3	1	-	-	1	2	1	1	3	-	-	1
CO3	2	3	3	2	2	2	2	1	2	2	1	3	-	-	1
CO4	3	2	3	2	1	-	-	1	2	1	1	3	-	-	-
CO5	1	3	3	2	1	1	-	1	2	1	2	2	-	-	1
AVG	2	2.4	3	2	1.6	1.3	1.5	1	2	1.2	1.2	2.4			1

Weightage Values:3=Stronglymatched,2=Moderatelymatched,1=Weaklymatched,(-)=Notmatched

Course Name: Advanced Bio Signal Processing

Course Code: EC703D

Contact: 3:0:0

Total Contact Hours: 36

Credits: 3

Prerequisite: Concept of signal and systems and Digital signal Processing

Course Outcomes

Graduates of the ECE program will be able to

CO1: Able to illustrate filtering of biomedical signals, classify Time domain filtering, and design different types of filters.

CO2: Able to analyze different components of ECG and EEG signals.

CO3: Able to estimate the value of the transformation using wavelet transform.

CO4: Able to describe the neurological signal processing and also describe adaptive interface and noise cancellation techniques.

CO5: Able to estimate modeling of Biomedical systems.

Course Content

Module 1:

2L

Introduction: Biomedical signal origin & dynamics (ECG), Biomedical signal origin & dynamics (EEG, EMG etc.)

Module 2:

5L

Filtering for Removal of artifacts: Statistical Preliminaries, Time domain filtering (Synchronized Averaging, Moving Average), Time domain filtering (Moving Average Filter to Integration, Derivative-based operator), Frequency Domain Filtering (Notch Filter), Optimal Filtering: The Wiener Filter. Optimal Filtering: The Wiener Filter, Adaptive Filtering Selecting Appropriate Filter.

Module 3:

5L

Event Detection: Example events (viz. P, QRS and T wave in ECG), Derivative based Approaches for QRS Detection Pan Tompkins Algorithm for QRS Detection, Dicrotic Notch Detection Correlation Analysis of EEG Signal.

Module 4:

8L

Waveform Analysis: Illustrations of problem with case studies, Morphological Analysis of ECG, Correlation coefficient, The Minimum phase correspondent. Signal length, Envelope Extraction, Amplitude demodulation, The Envelopogram, Analysis of activity, Root Mean Square value, Zero-crossing rate, Turns Count, Form factor.

Module 5:

3L

Frequency-domain Analysis: Periodogram, Averaged Periodogram, Blackman-Tukey Spectral Estimator, Daniell's Spectral Estimator, Measures derived from PSD.

Module 6:

6L

Modelling of Biomedical Systems: Motor unit firing pattern, Cardiac rhythm, Formants and pitch of speech, Point process, Parametric system modelling, Autoregressive model, Autocorrelation method, Application to random signals, Computation of model parameters, Levinson-Durbin algorithm, Computation of gain factor, Covariance method, Spectral matching and parameterization, Model order selection, Relation between AR and Cepstral coefficients. ARMA model, Sequential estimation of poles and zeros,

Module 7:

3L

Neurological signal processing: EEG analysis, Parametric modelling, Linear prediction theory; Autoregressive (AR) method; Recursive estimation of AR

parameters. Cardiological signal processing: ECG parameters and their estimation - Arrhythmia analysis monitoring- ECG data reduction techniques

Module 8:

4L

Adaptive interference / Noise cancellation: Types of noise in biosignals; Digital filters - IIR and FIR - Notch filters - Optimal and adaptive filters. Wiener filters - steepest descent algorithm - LMS adaptive algorithm - Adaptive noise canceller - cancellation of 50 Hz signal in ECG - Cancellation of maternal ECG in foetal electrocardiography.

Text Books:

1. John G. Proakis and Dimitris Manolakis G. "Digital Signal Processing, Algorithms and Applications", PHI of India Ltd., New Delhi, fourth Edition, 2007.
2. Rangaraj M Rangayyan, "Biomedical signal processing", IEEE press, first edition, 2002.

Reference Books:

1. Reddy D.C, "Biomedical Signal Processing: Principles and Techniques", Tata McGraw-Hill, New Delhi, 2nd edition, 2005.
2. Sanjit.K, Mitra "Digital Signal Processing", A Computer Based Approach", Tata McGraw-Hill, New Delhi, fourth edition 2011.

CO-PO-PSO MAPPING

	PO1	PO2	PO3	PO4	PO5	PO6	PO7	PO8	PO9	PO10	PO11	PO12	PSO1	PSO2	PSO3
CO1	2	2	2	1	3	1	2	2	3	3	2	2	-	-	-
CO2	3	3	3	3	2	1	1	1	2	2	3	3	-	-	1
CO3	3	2	2	2	1	1	3	1	3	1	3	1	-	-	1
CO4	3	3	3	1	2	1	1	3	2	2	2	3	-	-	-
CO5	2	3	2	2	2	1	1	1	2	3	3	2	-	-	-
Avg	2.6	2.6	2.4	1.8	2	1	1.6	1.6	2.4	2.2	2.6	2.2	-	-	1

Weightage Values: 3 = Strongly matched, 2 = Moderately matched, 1 = Weakly matched, (-) = Not matched

CourseName: Mixed Signal Design

CourseCode: EC703E

Contact: 3:0:0

Total Contact Hours: 36

Credits: 3

Prerequisite: EC304 Signals and Systems, EC601 VLSI and Microelectronics

Course Outcomes:

After the successful completion of this course students will be able to

CO1: Apply the concepts for mixed signal MOS circuit.

CO2: Demonstrate in-depth knowledge in Switched Capacitor Circuits, Data Converters – ADC and DAC, Filter and PLL.

CO3: Analyze the signal to noise ratio and modeling of mixed signals

CO4: Solve engineering problems responsibly with wider range of solutions to increase Data Rate of ADC and DAC for addressing social issues.

CO5: Contribute positively to society with multidisciplinary scientific research in design and development of Mixed Integrated Circuits suited for wide range of applications.

Course Content

Module 1: Introduction to Mixed Signal Design

[3L]

Introduction: Introduction to analog VLSI and mixed signal issues in CMOS technologies. MOS transistor: Introduction, Short channel effects, current source and current mirror, C-MOS circuit.

Module 2: Switched Capacitor Circuits

[8L]

Introduction to Switched Capacitor circuits- basic building blocks, Operation and Analysis, Non-ideal effects in switched capacitor circuits, Switched capacitor integrators first order filters, Switch sharing, Biquad filters.

Module3:Data Converter Fundamentals**[8L]**

Sampling and Aliasing:, Data converter circuits Analog versus discrete time signals.

DC and dynamic specifications, Quantization noise, Nyquist rate D/A converters- Decoder based Converters, Binary-Scaled converters, Thermometer-code converters, Hybrid converters

Module4:Data Converter Architectures**[9L]**

ADC and DAC specifications. DAC architectures. ADC architectures. Sampling and aliasing, Quantization noise & Data converter SNR **ramp, tracking, dual slope, successive approximation and flash types, Multi-stage flash type ADCs.**

Module5: Integrator Based CMOS Filter and PLL**[8L]**

Integrator Building Blocks , Lowpass Filters , Active-RC Integrators Effects of Finite Op-Amp Gain Bandwidth Product, Active-RC SNR, Why use an Active Circuit (an Op-Amp), PLL, Applications

Text Books:

1. R.J.Baker, CMOS Mixed-Signal Circuit Design
2. B.Razavi. Principles of Data Conversion System Design.
3. Behzad Razavi, "Design of Analog CMOS Integrated Circuits", TMH Edition, 2002
4. Richard Schreier, "Understanding Delta-Sigma Data converters", Wiley Interscience, 2005.

Reference Books:

1. Rudy Van De Plassche, "CMOS Integrated Analog-to-Digital and Digital-to-Analog converters", Kluwer Academic Publishers, 2003.
2. Philip E. Allen and Douglas R. Holberg, "CMOS Analog Circuit Design", Oxford University Press, International 2nd Edition/Indian Edition, 2010.
3. David A. Johns, Ken Martin, "Analog Integrated Circuit Design", Wiley Student Edition, 2010.

CO-PO-PSO MAPPING

	PO1	PO2	PO3	PO4	PO5	PO6	PO7	PO8	PO9	PO10	PO11	PO12	PSO1	PSO2	PSO3
CO1	3	2	3	2	3	3	1	1	2	2	1	3	-	-	-
CO2	3	1	2	2	3	2	2	-	2	1	2	2	-	-	-
CO3	2	2	1	2	2	1	1	-	3	2	3	3	-	-	-
CO4	2	2	2	2	3	2	2	3	2	1	2	1	-	-	-
CO5	3	3	3	2	2	2	1	3	2	1	1	3	-	-	-
AVG	2.6	2	2.2	2	2.6	2	1.4	2.3	2	1	1	3			

Weightage Values: 3=Strongly matched, 2=Moderately matched, 1=Weakly matched, (-)=Not matched

Course Name: Internet of Things Lab

Course Code: EC791A

Contacts:0:0:3

Credit:1.5

Course Outcomes: After this course students will be able to

CO1: understand internet of Things and its hardware and software components

CO2: interface I/O devices, sensors, actuators and communication modules

CO3: Remotely monitor data and control devices

CO4: Develop real life IoT based projects

Lab Experiments:

1. Familiarize with Arduino and Raspberry Pi with necessary installations
2. To interface LED or buzzer with Arduino and Raspberry Pi and turn on and off every one second.
3. Design of Traffic Management system with Arduino and Raspberry Pi
4. To interface DHT11 sensor with Arduino and Raspberry Pi and display temperature and humidity readings.
5. To interface motor or relay as actuator with Arduino and Raspberry Pi
6. Installation of Wireshark network protocol analyser and capture network traffic
7. Find machine IP address and packets sent using Wireshark capture
8. Implement MQTT protocol installing Node.js and Node-RED
9. Install Blynk App in mobile and control LED on/off remotely by mobile button
10. Set up an experiment for Ultrasonic Distance Measurement
11. Set up an experiment for ThinkSpeak based DHT Sensor Monitoring
12. Any other innovative experiments

Books

1. 21 IoT Experiments, Yashavant Kanetkar, Shrirang Korde, BPB

2. IoT based Projects: Realization with Raspberry Pi, Node MCU, Rajesh Singh Anita Gehlot, BPB

CO-PO-PSO MAPPING

CO	PO1	PO2	PO3	PO4	PO5	PO6	PO7	PO8	PO9	PO10	PO11	PO12	PSO1	PSO2	PSO3
CO1	2	2	2	2	3	2	1	1	2	2	3	3	2	2	1
CO2	2	3	3	3	3	1	1	1	2	2	3	3	2	2	2
CO3	3	3	2	3	3	2	2	2	3	3	3	3	3	2	2
CO4	3	3	2	2	2	1	1	1	1	1	2	3	2	1	3
AVG	2.5	2.8	2.3	2.5	2.8	1.5	1.3	1.3	2	2	2.8	3	2.3	1.8	2

Weightage Values:3=Stronglymatched,2=Moderatelymatched,1=Weaklymatched,(-)=Notmatched

Course Name: Artificial Intelligence Lab

Course Code:EC791B

Contacts:0:0:3

Credit:1.5

Course outcome:

Graduates of the ECE program will be able to

CO-1: Apply PROLOG to implement logic

CO-2: Analyze searching algorithm

CO-3: Apply ANN for classification

CO-4: Apply NLP using AI.

Experiments:

A. Using Prolog

1. Familiarization of Prolog
2. Study of facts, objects, predicates and variables in PROLOG.
3. Study of Rules and Unification in PROLOG.
4. Study of “cut” and “fail” predicate in PROLOG.
5. Write a Prolog program to maintain family tree.
6. Write predicates One converts centigrade temperature to Fahrenheit, the other checks if a temperature is below freezing.

B. Using any programming language

7. Write a program to solve the Tower of Hanoi problem.
8. Write a program to solve 4-Queen problem.
9. Write a program to solve 8-puzzle problem.
10. Write a program to solve traveling salesman problem.

11. Write a program to solve water jug problem
12. Write a program to implement hill climbing algorithm
13. Write a program to implement simulated annealing algorithm
14. Write a program to simulate breadth first search and depth first search
15. Write a program to solve the Monkey Banan problem.
16. Write a program to simulate hill climbing and simulated annealing
17. Write a program to implement Perceptron.
18. Write a program to implement AND, OR gates using Perceptron.
19. Write a program to implement Iris data classification using Back Propagation.
20. Write a program to implement a Chatbot
21. One experiment on NLP

Text Books:

1. Artificial Intelligence: A Modern Approach, Russell & Norvig, Prentice Hall.

3. Artificial Intelligence, Elaine Rich and Kevin Knight, TMH.

CO-PO-PSO MAPPING

	PO1	PO2	PO3	PO4	PO5	PO6	PO7	PO8	PO9	PO10	PO11	PO12	PSO1	PSO2	PSO3
CO1	3	3	3	3	3	2	2	-	1	1	3	3	3	2	3
CO2	3	3	3	3	3	2	-	1	-	1	3	3	3	3	3
CO3	3	3	3	3	3	2	2	-	1	1	3	3	3	3	3
CO4	3	3	3	3	3	2	-	1	-	1	3	3	3	3	3
AVG	3	3	3	3	3	2	2	1	1	1	3	3	3	2.8	3

Weightage Values: 3=Strongly matched, 2=Moderately matched, 1=Weakly matched, (-)=Not matched

CourseName:DigitalControlSystemLab

CourseCode:EC791C

Contact:0:0:3

Credit:1.5

Prerequisites:Knowledgeof MATLAB.

CourseOutcomes:

Oncompletionofthecoursestudentswillbeableto

- CO1.** Conductexperiments onPositionControlwithproPERTuningofP,PIandPIDcontroller.
- CO2.** DemonstrateLead-LagCompensators.
- CO3.** InvestigatetheresponseofaRealTimeSystemusingStateVariableAnalysis.
- CO4.** AnalyzePerformanceofDiscrete-TimeSystemaNon-LinearSystem.

ListofExperiment:

1. StudyofaPracticalPositionControlSystem:

Obtainingclosedstepresponsesforgainsettingcorrespondingtoover-dampedandunder-damped responses. Determination of rise time and peak time using individualizedcomponents in SIMULINK. Determination of un-damped natural frequency anddampingratiofromtheexperimentaldata.

2. Tuning of P, PI and PID Controller for First Order Plant with Dead Time using Z-NMethod:

Processparameters(timeconstantanddelay/lag)willbeprovided,thestudentswouldcomputecontrollergainsbyusingZ-Nmethod.Steadystateandtransientperformance of the closed loop plant with and without steady disturbances will have to benoted. Theoreticalphaseandgainmarginswillhavetobemanuallycomputedforeachgain settings.

3. DesignofLeadandLagCompensationUsingCacsadTools:

Planttransferfunctionwillbeprovided.Stepresponseistobeobtained.(PSPICE,MATLAB,SciLab may beused).

4. StateVariableAnalysisusingCacsadCommandTool:

Familiarization and use of CACSAD command for state variable analysis. Obtaining transfer function from SV model and vice versa. Obtaining step response for a SISO system given in SV form. (PSPICE, MATLAB, SciLab may be used).

5. State Variable Analysis using Cacsad Block Diagram Tool:

Familiarization and use of CACSAD BLOCK DIAGRAM TOOL for state variable analysis. Obtaining step response and initial condition response for a single input, two output system given in SV form. (PSPICE, MATLAB, SciLab may be used).

6. Performance Analysis of a Discrete Time System using Cacsad Tool:

Familiarization and use of CACSAD block diagram tool for Digital Control System. Study of closed response of a continuous system with a digital controller with sample and hold. (PSPICE, MATLAB, SciLab may be used).

7. Studying The Effect of Nonlinearity in a Feedback Controlled System using Time Response:

Determination of step response with limiternonlinearity introduced into the forward path of 2nd order unity feedback control systems. The open loop plant will have one pole at the origin and the other pole will be in LHP or RHP. To verify that (i) with open loop stable pole, the response is slowed down for larger amplitude input and (ii) for unstable plant, the closed loop system may become oscillatory with large input amplitude. (PSPICE, MATLAB, SciLab may be used).

8. Studying The Effect of Nonlinearity in a Feedback Controlled System using Phase Plane Plots:

Determination of phase plane trajectory and possibility of limit cycle of common nonlinearities. CACSAD block diagram tool will be used (PSPICE, MATLAB, SciLab may be used).

Note: From the list of experiments a minimum of 7 (seven) experiments shall have to be performed by each student.

Reference Books:

1. Herniter, Programming in MATLAB, Vikas
2. Ogata K : Modern Control Engg. 4e, Pearson/PHI

CO-PO-PSO MAPPING

COs	PO1	PO2	PO3	PO4	PO5	PO6	PO7	PO8	PO9	PO10	PO11	PO12	PSO1	PSO2	PSO3
CO1	2	3	3	2	2	2	2	1	2	1	3	3	-	2	-
CO2	3	2	2	3	2	1	-	-	2	-	1	2	-	-	-
CO3	3	3	3	3	3	2	1	-	2	-	1	2	-	2	-
CO4	2	3	2	2	3	2	-	2	2	2	3	3	-	-	-
AVG	2.5	2.75	2.5	2.5	2.5	1.75	1.5	1.5	2	1.5	2	2.5	-	2	-

Weightage Values: 3=Strongly matched, 2=Moderately matched, 1=Weakly matched, (-)=Not matched

Course Name: Cloud Computing (AWS) Lab

Course Code: EC791D

Contact: 0:0:3

Credits: 3

Prerequisite:

1. Should have basic knowledge on C and JAVA programming.
2. Prior knowledge on Operating System

Course Outcome(s):

On completion of this course, the students will be able to:

CO1: Configure various virtualization tools such as VirtualBox, VMware workstation.

CO2: Design and deploy a web application in a PaaS environment.

CO3: Learn how to simulate a cloud environment to implement new schedulers.

CO4: Install and use a generic cloud environment that can be used as a private cloud.

Experiments:

1. Installation of VMware Workstation on Windows OS (version Windows 7 to 10).
2. Installation of C compiler and execute simple programs of C using virtual machine.
3. Create a hello world application and other simple web applications using Python/JAVA in Google App Engine.
4. Launching of web applications using GAE launcher.
5. Creating a cloud environment using CloudSim and run a scheduling algorithm that is not present in CloudSim.
6. Transferring the files from one virtual machine to another virtual machine.
7. Find a procedure to launch virtual machine using Trystack (Online OpenStack Demo Version)
8. Install Hadoop single node cluster and run simple applications like word count.

TextBooks:

1. MasteringCloudComputingbyRajkumarBuyya,ChristianVecchiola,S.ThamaraiSelvi,McGrawHill Education (India)PrivateLimited, 2013
2. FundamentalsofCloudComputingbyP.K.Pattnaik,S.Pal,M.R.Kabat,VikasPublications,2014.

ReferenceBooks:

1. CloudComputingBiblebyBarrieSosinsky,WileyIndiaPvt.Ltd,2013
2. Cloudcomputing:Apracticalapproach,AnthonyT.Velte,TataMcgraw-Hill

CO-PO-PSO MAPPING

	PO1	PO2	PO3	PO4	PO5	PO6	PO7	PO8	PO9	PO10	PO11	PO12	PSO1	PSO2	PSO3
CO1	3	2	3	2	2	-	-	-	-	-	2	2	-	-	-
CO2	2	3	3	2	1	-	1	-	-	-	3	3	-	-	-
CO3	3	2	3	2	2	2	-	-	2	-	2	2	-	-	-
CO4	2	3	3	2	-	-	-	2	1	-	3	3	-	-	-
AVG	2.5	2.5	3	2	1.7	2	1	2	1.5		2.5	2.5	-	-	-

WeightageValues:3=Stronglymatched,2=Moderatelymatched,1=Weaklymatched,(-)=Notmatched.

Course Name: DATA SCIENCE LAB

CourseCode:EC793A

Contacts: 0:0:3

Credit:1.5

CourseOutcome:

StudentsofECEprogramwillbeableto:

CO1:UnderstandthePythonProgrammingLanguage.

CO2:Exposethemselveson solvingofdatascienceproblems.

CO3:Understand theclassificationandRegression Model.

CO4:Understandandapplyprinciplesofdatavisualization.

CO5:SetupAnacondaand Jupyternotebooks

Experiments:

1. SettingUpAnacondaandJupyterNotebook.
2. DESCRIPTIVESTATISTICSINJupitarHandbook

a. WriteanRscripttofindbasicdescriptivestatisticsusingsummary,str,quartilefunctiononmtcars& carsdatasets.

b.WriteanRscripttofindsubsetofdatasetbyusingsubset(),aggregate()functionsonirisdataset

3. READINGANDWRITINGDIFFERENTTYPE
SOFDATASETS

a.Readingdifferent

types of datasets (.txt,.csv) fromWeb and disk andwritingin file in specific disk location.

b. ReadingExceldatasheetinJupiter.c.Reading
XMLdatasetinJupiter

4. Visualization

a.Findthedatadistributionsusingboxandscatterplot.b.Findtheoutliersusingplot.

c.Plotthehistogram,barchartandpiechartonsampled data.

5.Statistics and NumPy

IntroductiontoStatisticsDistribution

StandardizationinDataScienceWorkingwithNumpy

6.WorkingWithPANDASArrays

Working With Queries WorkingWithDataFramesUsingGROUPBYMergingandJoining

7. CORRELATIONANDCOVARIANCE

- Findthecorrelationmatrix.
- Plotthecorrelationplotondatasetandvisualizegivinganoverviewofrelationshipsamongdataon irisdata.

Analysisofcovariance:variance(ANOVA),ifdatahavecategoricalvariablesonirisdata.

8.REGRESSIONMODEL

Importadatafromwebstorage.NamethedatasetandnowdoLogisticRegressiontofindoutrelationbetweenvariablesthat are affectingtheadmissionofastudentinainstitutebased

onhisor herGREscore,GPAobtainedandrankofthestudent.Alsocheckthe modelisfitornot.Require(foreign), require(MASS).

9.CLASSIFICATIONMODEL

- Installrelevantpackageforclassification.
- Chooseclassifierforclassificationproblem.
- Evaluatetheperformanceofclassifier.

ReferenceBooks:

YanchangZhao,“RandDataMining:ExamplesandCaseStudies”,Elsevier,1stEdition,2012WebReferences:

- <http://www.r-bloggers.com/how-to-perform-a-logistic-regression-in-r/>
- <http://www.ats.ucla.edu/stat/r/dae/rreg.htm>

- <http://www.coastal.edu/kingw/statistics/R-tutorials/logistic.html>

4.

<http://www.ats.ucla.edu/stat/r/data/binary.csv>

SOFTWAREAND HARDWARE REQUIREMENTS FOR 18 STUDENTS:

SOFTWARE:RSoftware,RStudioSoftware

HARDWARE:18numbersofIntelDesktopComputerswith4GBRAM

CO-PO-PSO MAPPING

COs	PO1	PO2	PO3	PO4	PO5	PO6	PO7	PO8	PO9	PO10	PO11	PO12	PSO1	PSO2	PSO3
CO1	3	2	1	1	-	-	-	1	2	2	1	2	-	-	1
CO2	3	2	1	2	2	-	-	1	2	2	1	2	-	-	-
CO3	3	3	1	1	2	-	-	1	2	1	1	2	-	-	1
CO4	3	3	3	2	2	1	1	1	3	2	2	3	-	-	-
CO5	3	2	1	1	-	-	-	-	1	1	1	2	-	-	-
AVG	3	2	1	1	-	-	-	-	1	1	1	2	-	-	-

Weightage Values:3=Stronglymatched,2=Moderatelymatched,1=Weaklymatched,(-)=Notmatched

Course name: Machine LearningLab

Course Code:EC793B

Contact:0:0:3

Credits:3

Prerequisites:

- Basicprogrammingknowledgeandalgorithm

GraduatesoftheECEprogramwillbeabletoCourseoutcomes:

CO1:Able toanalyze linear regressionmodel.

CO2:Abletoevaluatetheimportantfeaturesfromdata

CO3: Able to apply classifier to find the pattern fromdata.

CO4:Abletoevaluatemodelsgeneratedfromdata.

CO5:Able to demonstrate thecurseofdimensionality.

Toperformthefollowing experiments,itis recommendedtogetthedata fromtheopen-sourceUCIMachineLearningRepository.

Link:<https://archive.ics.uci.edu/ml/index.php>

1. Takeasuitabledatasetandstudythelinearregressionwithonevariableandmultiplevariables.
2. Study the effect of bias and variance inlinearregression.
3. Takeasuitabledatasetandselectthegoodfeaturesusingfilterandwrappermethod.TakeasuitabledatasetandextractthefeaturesusingPCAandLDA
4. Take a suitabledataset anddesignaclassifierusing
 - Logisticregression
 - Decisiontrees
 - NaïveBayesClassifier
 - KNN
 - SVM
5. Takeasuitabledatasetandclusterthedatausing
 - K-means
 - Hierarchicalclustering
6. Inagivendataset,estimatethenumberofpossibleclustusing Silhouettemethod
7. Takeasuitabledataset,designANNbasedclassifierandstudythefollowings:
 - effect ofsinglelayer,multilayer

- effectofnumberofnodesinalayer

9.Takeasuitabledatasettoillustratetheimportanceoftrainingandtest

accuracyincaseof supervisedlearning.

10.Takeasuitabledatasettoshow thecurseofdimensionalityandits

solutionusingSammonmapping.

Textbooks:

1. Patternrecognitionand machinelearningbyChristopherM.Bishop,Springer
2. UnderstandingMachineLearningbyShaiShalev-ShwartzandShaiBen-David,CambridgeUniversityPress
3. PatternClassificationbyRichardODuda,PeterE.Hart&David
G.Stock,JohnWiley.4.PatternRecognitionbyKonstantinosKoutroumbas,SergiosTheodoridis,Elsevier

CO-PO-PSO MAPPING

	PO1	PO2	PO3	PO4	PO5	PO6	PO7	PO8	PO9	PO10	PO11	PO12	PSO1	PSO2	PSO3
CO1	3	3	3	3	3				2	1		3	1	1	3
CO2	2	2	2	2	2				-	1		3	1	1	3
CO3	3	2	3	3	3				-	1		3	1	1	3
CO4	2	3	2	2	2				2	1		3	1	1	3
AVG	3	3	3	3	3				2	1		3	1	1	3

WeightageValues:3=Stronglymatched,2=Moderatelymatched,1=Weaklymatched,(-)Notmatched

Course Name: Cyber Security & Cryptography Lab

CourseCode: EC793C

Contacts: 0:0:3

Credits:1.5

Courseoutcome:

CO1: Able to analyze the ciphertechnique

CO2: Able to apply Hashfunctions

CO3: Able to apply AES, DESalgorithm

CO4: Able to analyze RSAalgorithm.

Experiments:

1. Breakingthe ShiftCipher
2. BreakingtheMono-alphabeticSubstitutionCipher
3. One-TimePadandPerfectSecrecy
4. MessageAuthenticationCodes
5. CryptographicHash FunctionsandApplications
6. SymmetricKeyEncryption Standards(DES)
7. SymmetricKeyEncryptionStandards(AES)
8. Diffie-HellmanKeyEstablishment
9. Public-KeyCryptosystems (PKCSv1.5)
10. ImplementationofRSAalgorithm.

Textbooks

[1] Kahate,A.(2013).Cryptographyandnetworksecurity.TataMcGraw-HillEducation.

[2] Forouzan,B.A.,&Mukhopadhyay,D.(2015).Cryptographyandnetworksecurity.NewYork,NY:McGrawHill Education (India)PrivateLimited.

ReferenceBooks

- [1] Stallings, W. (2006). Cryptography and network security, 4/E. Pearson Education India.
- [2] Daras, N. J., & Rassias, M. T. (Eds.). (2015). Computation, cryptography, and network security (pp. 253-287). Springer.
- [3] Kumar, A., & Bose, S. (2017). Cryptography and network security. Pearson Education India.

CO-PO-PSO MAPPING

CO	PO1	PO2	PO3	PO4	PO5	PO6	PO7	PO8	PO9	PO10	PO11	PO12	PSO1	PSO2	PSO3
CO1	2	2	3	1	3	1	1	1	2	1	1	1	-	-	2
CO2	2	2	3	3	1	-	-	1	2	1	1	3	-	-	1
CO3	2	3	3	2	2	2	2	1	2	2	1	3	-	-	-
CO4	3	2	3	2	1	-	-	1	2	1	1	3	-	-	-
AVG	2.25	2.25	3	2	1.75	1.5	1.5	1	2	1.25	1	2.5			1.5

Weightage Values: 3=Strongly matched, 2=Moderately matched, 1=Weakly matched, (-)=Not matched

CourseName:AdvancedBioSignalProcessingLab

Course Code:EC793D

Contacts: 0:0:3

Credit:1.5

Prerequisite: *DigitalElectronics,AnalogElectronics,MicroprocessorandMicrocontroller,Sensors,C/C++programming,Pythonprogramming*

CourseOutcomes:

GraduatesoftheECEprogramwillbeableto

CO1:AnalyzeBioelectric signals,humanphysiologicalsystem,anddifferenttypesoftransducers.

CO2:Design differenttypesofmedicalmeasurementsystem.

CO3: Able to examine the data handling, filtering techniques of bio-medical signals and able toanalysisof timeand frequencydomain.

CO4: Able to simulate medical imaging techniques and implement different algorithms to featureextractthesignals.

Experiments

1. TosimulateElectrocardiogramWaveform
2. TosimulateElectroencephalogramSignal
3. TosimulateElectromyogramSignal
4. ToSimulateDefibrillator
5. TosimulatePacemaker
6. TosimulateHemodialysisMachine
7. TosimulateBiopotential Amplifier

8. TosimulateECGPulsemissing detector
9. Tosimulate12LeadECGSignals

Reference:

1. WaveletsandTimefrequencymethodsforBiomedicalsignalProcessing- M.Akay,IEEEPress,DigitalProcessing ofspeech signals- L.Rabinar,PearsonEducation.
2. BiomedicalInstrumentationandMeasurements-Cromwell,WeibellandPfeiffer,PHI
3. <https://bmsp-coep.vlabs.ac.in>

CO-PO-PSO MAPPING

	PO1	PO2	PO3	PO4	PO5	PO6	PO7	PO8	PO9	PO10	PO11	PO12	PSO1	PSO2	PSO3
CO1	2	-	1	-	-	3	-	1	1	1	1	3	-	-	-
CO2	-	3	-	2	-	1	-	-	-	-	-	2	-	-	-
CO3	3	-	-	-	1	3	3	-	2	2	2	3	-	-	-
CO4	2	-	1	3	3	-	2	1	-	-	1	2	-	-	-
AVG	2.3	3	1	2.5	2	2.3	2.5	1	1.5	1.5	1.3	2.5	-	-	-

Weightage Values:3=Stronglymatched,2=Moderatelymatched,1=Weaklymatched,(-)=Notmatched

Course Name: Mixed Signal Design Lab

Course Code: EC793E

Contacts: 0:0:3

Credits: 1.5

Prerequisite: EC304 Signals and Systems, EC601 VLSI and Microelectronics

Course Outcomes: After the successful completion of this course students will be able to

CO1: Design and operation of the CMOS basic logic element and understanding of basic DC characteristics of the CMOS integrated circuits

CO2: Design of Switched Capacitor Circuits, Data Converters—ADC and DAC, Filter and PLL

CO3:

Apply the knowledge of DC testing in MOS circuits, determination of signal to noise ratio and modeling of mixed signals

CO4:

Solve engineering problems responsibly with wider range of solutions to increase Data Rate of ADC and DAC for addressing social issues.

CO5: Design of low pass and high pass active filters and study of its frequency response

Course Content:

1. Design and operation of the CMOS basic logic element to understand basic DC characteristics of the CMOS integrated circuits, as well as their dynamic properties during switching processes.
2. DC testing of n-channel and p-channel enhancement mode MOSFETs and measure the Current flowing through the transistor.
3. Verify the operation of basic switched capacitor filter
4. Design an ADC circuit that converts Analog input signals to corresponding binary output values and build, test, and troubleshoot an ADC circuit using Spice.
5. To Design and Simulate Binary to Gray, Gray to Binary, BCD to Excess 3, Excess 3 to BCD code converters.
6. Design of low pass and high pass active filter using OPAMP and study of its frequency response.
7. Verify the validity of the theory behind sampling and quantization.
8. Design and construct RC integrator circuit and study its pulse response.

9. Experiment to observe the operation of the PLL subsystem and recognize the three PLL states in actual circuits, and you will also gain some insight into how circuit values affect PLL operation.

CO-PO-PSO MAPPING

COs	PO1	PO2	PO3	PO4	PO5	PO6	PO7	PO8	PO9	PO10	PO11	PO12	PSO1	PSO2	PSO3
CO1	3	2	3	3	2	1	1	-	2	2	2	2	-	-	-
CO2	3	2	2	2	3	2	2	-	2	1	3	3	-	-	-
CO3	2	2	1	2	2	1	1	-	2	2	2	2	-	-	-
CO4	2	2	2	3	3	2	2	3	2	1	3	3	-	-	-
CO5	3	2	2	2	2	2	1	3	2	1	2	1	-	-	-
AVG	2.6	2	2	2.4	2.4	1.6	1.4	3	2	1.4	2.4	2.2	-	-	-

Weightage Values: 3 = Strongly matched, 2 = Moderately matched, 1 = Weakly matched, (-) = Notmatched

Stream: ECE

Subject Name: MajorProject-I

Subject Code: PR791

Contact hour: 4P

Total contact hour- 40

Credits: 2

Prerequisite: Course completed up to 6th semester in UG ECE

Course Objective:

Prepare students with foundation knowledge in a project domain through surveying, designing, implementing, observing and reporting.

Methodology:

1. Thinking: Discussion on innovative idea.
2. Exploring: Survey of recent research.
3. Implementing: Project guidance to basic prototype implementation.
4. Documenting: Guidance on reporting and conference paper writing.
5. Each Major Project –I group should submit the following under their semester project report submission with items not limited to,

Title, certificates, declaration by student, acknowledgement, Table of Contents, abstract, keywords, Introduction, Literature Survey, System Analysis (if applicable), System Design (if applicable), Coding, Testing (if applicable), Conclusion, Future Scope of work), reference

Course outcome:

Sem. No.	Course Title (Code)	CO Codes	Course Outcomes
			On completion of the course students will be able to
7 th	Major Project-I (PR791)	CO1	Apply the knowledge acquired through survey of recent research to set the project goal.
		CO2	Distinguish the way of implementation of prototype
		CO3	Identify the fault issue through various case study
		CO4	Implement the prototype using modern tools

		CO5	Demonstrate the project design to share the idea through conference/workshop/seminar etc.
		CO6	Modify the project design for the benefit to societal issues

CO-PO-PSO MAPPING

COs\POs	PO1	PO2	PO3	PO4	PO5	PO6	PO7	PO8	PO9	PO10	PO11	PO12	PSO1	PSO2	PSO3
CO1	3	3	3	2	1	1	3		1	1		3	2	3	
CO2	3	3	3	3	3			3	3		2	3	3	3	2
CO3	2		3	3	2	2	3	3	2	2		3	3	2	1
CO4	1	3	3	2	3		3	2	3		2	3	3	3	3
CO5	3		2	3	3	2		3	3	2		3	3	3	2
CO6	3	3	3	2		2	3			2		3	2		3
AVG	2.5	3	2.83	2.5	2.4	1.75	3	2.75	2.4	1.75	2	3	2.67	2.8	2.2

Stream: ECE

Subject Name: Skill Development VII: Seminar & Group Discussion

Subject Code: PR792

Contact hour: 1

Total contact hour- 10

Credits: 0.5

Prerequisite: Course completed up to 6th semester in UG ECE

Objectives:

5. To show competence in identifying relevant information, defining and explaining topics under discussion. To build depth of understanding, using primary and secondary sources.
6. To use appropriate registers and vocabulary, demonstration command with voice modulation, voice projection, and pacing.
7. To use of visual, audio and audio-visual material to support presentation
8. To speak cogently with or without notes, present either in groups or as individuals.

Course outcome:

Sem. No.	Course Title (Code)	CO Codes	Course Outcomes
			On completion of the course students will be able to
7 th	Skill Development VII: Seminar & Group Discussion (PR792)	CO.PR792.1	Show competence in identifying relevant information, defining and explaining topics under discussion.
		CO.PR792.2	Demonstrate command of voice modulation, voice projection, and pacing.
		CO.PR792.3	Judge when to speak and how much to say, speak clearly and audibly in a manner appropriate to the subject
		CO.PR792.4	Ask appropriate questions, use evidence to support claims, respond to a range of questions,
		CO.PR792.5	Take part in meaningful discussion to reach a shared understanding
		CO.PR792.6	Speak cogently with or without notes and present either in groups or as individuals.

CO-PO-PSO MAPPING

COs\POs	PO1	PO2	PO3	PO4	PO5	PO6	PO7	PO8	PO9	PO10	PO11	PO12	PSO1	PSO2	PSO3
CO1	3	2	3		1	1	3		1	1		3	2	3	
CO2	3	3	3	2	3			3	3		2	3	3	3	2
CO3	3	3	2	1	2	2	3	3	2	2		3	3	2	1
CO4	3	3	3	3	3		3	2	3		2	3	3	3	3

CO5	3	3	3	2	3	2		3	3	2		3	3	3	2
AVG	3	2.8	2.8	2	2.4	1.67	3	2.75	2.4	1.67	2	3	2.8	2.8	2

Stream: ECE

Subject Name: Industrial Training / Internship

Subject Code: PR793

Contact hour: NIL

Total contact hour- NIL

Credits: 2

Prerequisite: Course completed up to 6th semester in UG ECE

Objectives:

1. Understand the Organizational Structure of a company.
2. Develop work habits and attitudes necessary for job success (technical competence, professional attitude, organization skills etc.)
3. Develop written communication and technical report writing skills.
4. Develop knowledge of contemporary issues.
5. Develop an awareness for the need and applications of standards in the industry.

Course outcome:

Sem. No.	Course Title (Code)	CO Codes	Course Outcomes
			On completion of the course students will be able to
7 th	Industrial Training / Internship (PR793)	CO.PR793.1	Participate in the projects in industries during his or her industrial training.
		CO.PR793.2	Describe use of advanced tools and techniques encountered during industrial training and visit.
		CO.PR793.3	Interact with industrial personnel and follow engineering practices and discipline prescribed in industry.
		CO.PR793.4	Develop awareness about general workplace behavior and build interpersonal and team skills.
		CO.PR793.5	Prepare professional work reports and presentations.

CO-PO-PSO MAPPING

COs\POs	PO1	PO2	PO3	PO4	PO5	PO6	PO7	PO8	PO9	PO10	PO11	PO12	PSO1	PSO2	PSO3
CO1	1	1	3		1	1	3		1	1		3	2	3	

CO2	3			3	3			3	3		2	3	3	3	2
CO3	2	2	3	3	2	2	3	3	2	2		3	3	2	1
CO4	3		3	2	3		3	2	3		2	3	3	3	3
CO5	3	2		3	3	2		3	3	2		3	3	3	2
AVG	2.4	1.67	3	2.75	2.4	1.67	3	2.75	2.4	1.67	2	3	2.8	2.8	2

Course Name: Entrepreneurship & Innovation skill

CourseCode: MC701

Contact:2:0:0

Total Contact Hours: 24

Credit: 0

Prerequisite: None

CourseOutcomes:GraduatesoftheECEprogramwillbeableto

CO1:Comprehendtheroleofboundedrationality,framing,causationandeffectuationinentrepreneurialdecisionmaking.

CO2:Demonstrateanabilitytodesignabusinessmodelcanvas.

CO3:Evaluatevariousourcesoffraisingfinanceforstartupventures.

CO4:Explainthefundamentalsofdevelopingandpresentingbusinesspitchingtopotentialinvestors.

CourseContent

Module1: **4 L**

IntroductiontoEntrepreneurship:Entrepreneurs;entrepreneurialpersonalityandintentions-characteristics,traitsandbehavioral;entrepreneurialchallenges.EntrepreneurialOpportunities:Opportunities.discovery/ creation, Pattern identification and recognition for venture creation: prototypeandexemplar model,reverseengineering.

Module2: **4 L**

Entrepreneurial Process and Decision Making: Entrepreneurial ecosystem, Ideation, development and exploitation of opportunities; Negotiation, decision making process and approaches, Effectuation and Causation; Advantage and Limitation of Entrepreneurship; Process of Entrepreneurship.

Module3: **4L**

CraftingbusinessmodelsandLeanStart-ups:Introductiontobusinessmodels;Creatingvaluepropositions-conventionalindustrylogic,valueinnovationlogic;customerfocusedinnovation;buildingand analyzing business models; Business model canvas, Introduction to lean startups, Business Pitching.**Module4:** **4**

L

Organizing Business and Entrepreneurial Finance: Forms of business organizations; organizational structures; Evolution of Organisation, sources and selection of venture finance options and its managerial implications. Policy Initiatives and focus; role of institutions in promoting entrepreneurship.

Module5: **4 L**

Entrepreneurs as problem solvers: Innovations and Entrepreneurial Ventures – Global and Indian; Role of Technology – E-commerce and social media; Social Entrepreneurship – Concept; Entrepreneurship – The Indian Scenario

Module 6:**4L****Project/Case Study: (Any One)**

1. Visit of the District Industries Centre and prepare a report of activities and programs undertaken by them
2. Conduct a case study of any entrepreneurial venture in your nearby area.
3. Field Visit: Visit any business firm near your locality; interact with the owner of the business firm and prepare a field report on parameters like: type of business, scale of business, product/service dealing in, target customer, problems faced and measures to solve the faced challenges.
4. Know your State Handicraft and Handlooms as a means of economic activity

Text Books:

1. Bessant, J. (2003) High Involvement Innovation: Building and Sustaining Competitive Advantage Through Continuous Change. Chichester: John Wiley & Sons.
2. Bygrave, W and Zaccarakis, A (2013) Entrepreneurship, 3rd Edition, John Wiley and Co. Drucker, P. (1999) Innovation and Entrepreneurship, Butterworth Heinemann, Oxford.
3. Fagerberg, J, Mowery, DC and Nelson, RR (2005) The Oxford Handbook of Innovation, Oxford University Press, NY.
4. Hisrich, R.D., Peters, M.P., and Shepherd, D. (2013) Entrepreneurship, McGraw-Hill Irwin, Boston.
5. Kuratko, D. (2013) Entrepreneurship: Theory, Process, and Practice, 9th Edition, Wiley online library.
6. Moore, Geoffrey, (1999) Crossing the Chasm, Harper & Collins.
7. Porter, ME, Competitive Advantage: Creating and Sustaining Superior Performance, Free Press, New York, NY, 1985

4.**CO-PO-PSO MAPPING**

CO	PO1	PO2	PO3	PO4	PO5	PO6	PO7	PO8	PO9	PO10	PO11	PO12
CO1	3	-	1	2	3	1	-	2	-	2	3	3
CO2	2	1	-	1	-	-	1	-	1	-	2	2
CO3	3	-	2	-	2	3	-	1	-	2	3	3
CO4	2	2	-	1	-	1	-	2	2	1	2	2

Weightage Values: 3=Strongly matched, 2=Moderately matched, 1=Weakly matched, (-)=Not matched

R21(B.TechECE)

CurriculumforB.Tech

UnderAutonomy

Electronics&CommunicationEngineering

(EffectiveFrom2021-22admissionBatch)

L–Lecture;T-Tutorial;P-Practical[1L=1Cr,1T=1Cr,1P=0.5Cr]

4thYear2ndSemester: 8thSemester

SL. No.	CourseCode	PaperCode	Theory	ContactHours /Week			Credits /Unit	
				L	T	P		Total
A.THEORY								
1	PE	EC801	ProfessionalElective-VI A:IndustrialAutomation&Robotics B:ElectronicSystemDesign C:AutomotiveElectronics D:AdaptiveSignalProcessing	3	0	0	3	3
2	OE	EC802	Open Elective-IV A:BlockChain B:DeepLearning C:BiologyforEngineers D:ForeignLanguage E:ProductDesign&Manufacturing Processes F:BusinessResearchMethod	3	0	0	3	3
B.PRACTICAL								

4	PROJECT	PR891	MajorProject-II	0	0	0	12	6	
5	PROJECT	PR892	GrandViva	0	0	0	0	1	
C.MANDATORYACTIVITIES/COURSES									
8	MC	MC 801	EssenceofIndianKnowledgeTradition	0	0	3	3	3	
TOTALCREDIT								Units	13

Course Name: Industrial Automation & Robotics

CourseCode: EC801A

Contact:3:0:0

Total Contact Hours: 36

Credits: 3

Prerequisite:ElectricalNetworks&ControlSystem

Linearagebraandprobabilitytheory.Basicunderstandingofcontrolsystemsandcomputing.

CourseOutcomes:

TheGraduates oftheECEprogramwill be ableto:

CO1: Identify different components of an automation system.

CO2: Interface the given I/O device with appropriate PLC

CO3: Prepare a PLC ladder program for the given application.

CO4: Gain knowledgeof Elementsof robots.

CO5:Calculatetheforwardkinematicsandinversekinematicsofserialandparallelrobots.

CO6: Abletodothemotion planning&control for arobotic system.

CourseContent:

Module 1:

[6L]

Introduction:

ArchitectureofIndustrialAutomationSystems,MeasurementSystemsCharacteristics,DataAcquisitionSystems, Types of Sensors and Transducers.

Module 2:

[8L]

Introduction to Programmable Logic Controllers: advantages & disadvantages of PLC with respect to relay logic, PLC architecture, Input Output modules, PLC interfacing with plant, memory structure of PLC.

PLC programming methodologies: ladder diagram, PLC functions: bit logic instructions, ladder diagram examples, interlocking, latching, inter dependency and logical functions, PLC Timer & Counter functions-on-delay timer, off-delay timers, retentive on-delay timers, pulse timers, timer examples, up-counter, down-counter and up-down counter, counter examples, register basics.

Module 3:

[4L]

PLC Data Handling: data move instructions, table and register moves, PLC FIFO & LIFO functions. PLC arithmetic and logical functions: addition, subtraction, multiplication, division instructions, increment, decrement, trigonometric and log functions, AND, OR XOR, NOT functions, PLC compare and convert functions.

PLC program control and interrupts: jumps, subroutine, sequence control relay, watchdog. PID Control of Continuous process.

Module 4: Elements of robots:

[6L]

Position and orientation of a rigid body, Homogeneous transformations, Representation of joints, link representation using D-H parameters, Examples of D-H parameters and link transforms, different kinds of actuators – stepper, DC servo motors, Purpose of sensors – tachometers, strain gauge-based force-torque sensors, proximity sensors and vision.

Module 5: Kinematics of robots:

[8L]

Direct and inverse kinematics problems, Examples of kinematics of common serial manipulators, workspace of a serial robot, Inverse kinematics of constrained and redundant robots, Degrees of freedom of parallel mechanisms and manipulators, Active and passive joints, Constraint and loop-closure equations, Direct kinematics problem, Mobility of parallel manipulators.

Module 6: Motion planning and control:

[4L]

Joint and Cartesian space trajectory planning and generation, Classical control concepts using the example of control of a single link, Independent joint PID control, Control of a multi-link manipulator, Non-linear model-based control schemes.

Textbooks:

1. T.A. HUGHES: Programmable Controllers.

2. C.D.JOHNSON:ProcessControlInstrumentation.
3. Robotics:FundamentalConceptsandAnalysis,AshitavaGhosal,OXFORDUniversityPress.

ReferenceBooks:

1. JOHNWEBB:ProgrammableLogicControllersPrinciples&applications,PHI
2. Industrial Instrumentation, Control and Automation, S. Mukhopadhyay, S. Sen and A. K. Deb, JaicoPublishingHouse, 2013.
3. S.R.Deb,RoboticsTechnologyandflexibleautomation, TataMcGraw-Hill Education.

CO-PO-PSO MAPPING

	PO1	PO2	PO3	PO4	PO5	PO6	PO7	PO8	PO9	PO10	PO11	PO12	PSO1	PSO2	PSO3
CO1	3	3	3	3	2		2		3	-	-	3	3	2	2
CO2	3	3	3	3	2	2	2		3	-	2	3	3	2	2
CO3	3	2	3	2	2	-	2		3	2	-	3	1	2	2
CO4	3	3	3	3	2	-	2	2	3	-	-	3	3	2	1
CO5	2	3	2	3	2	-	2		3	-	-	3	3	1	1
AVG	2.8	2.8	2.8	2.8	2	2	2	2	3	2	2	3	2.6	1.8	1.6

WeightageValues: 3=Stronglymatched,2 =Moderatelymatched,1 =Weaklymatched, (-)= Notmatched.

Course Name: Electronic System Design

CourseCode:EC801B

Contact: 3:0;0

Total Contact Hours: 36

Credits:3

Prerequisite: Knowledge of Analog Electronic Circuit, Digital Electronic Circuit, Microprocessor&Microcontroller.

Courseobjectives: GraduateswillhavetogathertheconceptualandpracticalunderstandingofElectronicSystemsand theirdesignperspective.

CourseOutcome:

CO-1:GraduateswillbeabletodesignandanalyzeAnalogElectronicSystems.

CO-2: Graduates will be able to design and analyze Digital Electronic Systems.

CO-3:Graduateswillbe abletodesignPCBforvariousElectronicCircuits.

CO-4:GraduateswillbeabletofindfaultandtestElectronicSystems.

CourseContent:

1. Introduction: [8L]

Different Stages in product design- Market Survey, Product Specifications, R&D and Prototypes, Batchprocessing,Environmentaltesting, Manufacturing.

Electronic Products Classification: Consumer, Industrial and Military, Comparative study in terms ofreliability.Bathtubcurve,Measurestaken(at ComponentandProduct level)toimprovereliability.

VarioussolderingtechniquesincludingSurfaceMountTechnology.

1. AnalogDesign: [8L]

Analog signal conditioning: Op-Amps for signal conditioning and applications, Instrumentation Amplifierdesign using discrete components and special purpose IC. Amplification of Low-level signals, Grounding,Shielding and Guarding techniques. Design of Data Acquisition Systems- Interpretation of A/D

and D/Aspecifications from design viewpoint, Dual slope, Quad slope and high-speed A/D converters, Microprocessors Compatible A/D converters, Sample and Hold Circuit, considerations in selecting references for data converter

2. Digital Design: [8L]

Interfacing of LED, LCD, Keyboard, Relays (Electromagnetic and Solid State) with Microcontrollers. Microcontroller specifications and performance determining factors, Comparative study of different Microcontroller architectures, Comparison of buses and protocols used in electronic products- I2C, SPI, CAN, LIN, Flexray.

3. Software Design and Testing: [7L]

Different approaches for development of application software for Electronic Product. Assemblers, Assembly language and High-level language, debugging tools and techniques for software, Features of Simulators, ICE, IDE

4. PCB Design: [6L]

PCB Design practices for Analog and Mixed signal circuits: Ground Loops, Precision circuits, shielding and guarding. PCB Design Practices for High-speed digital circuits, Signal integrity and EMI/EMC for PCB design

5. Fault Finding and Testing: [7L]

Analyses- DC/ Operating Point Analysis, AC (Frequency Response), Transient, Sensitivity, Monte Carlo. Debugging/ Fault finding- Features and limitations of Analog CRO, DSO, Spectrum analyzer, Logic Analyzer and Mixed Signal Oscilloscopes in finding hardware/software faults. Environmental Testing: Need for Environmental Testing, Temperature, Humidity Tests, EMI/EMC testing standards and compliance

Textbooks:

Bernhard E. Bürdek, "History, Theory and Practice of Product Design", Springer Science, 2005
 Paul Horowitz, "Art of Electronics", Cambridge University Press

Howard Johnson, Martin Graham, "High-speed Digital design- A Handbook of Black Magic", Prentice Hall Publication

G. Pahl and W. Beitz, J. Feldhusen and K.-H. Grote, "Engineering Design- A Systematic Approach", Springer, 2007

Tim Williams, "EMC for Product Designers", Elsevier, Fourth edition 2007

References:

Jerry C Whitaker, "The Electronics Handbook", CRC Press, IEEE Press, ISBN 0-8493-8345-

5 David Bailey, "Practical Radio Engineering and Telemetry for Industry", Elsevier, ISBN 0750658037
 Pressman, "Software Engineering- A Practitioner's Approach"

Domine Leenaerts, Johan van der Tang, Cicero S. Vaucher, "Circuit Design for RF Transceivers", Kluwer Academic Publishers, 2003.

CO-PO-PSO MAPPING

CO	PO1	PO2	PO3	PO4	PO5	PO6	PO7	PO8	PO9	PO10	PO11	PO12	PSO1	PSO2	PSO3
CO1	3	2	2	1	1	2	1	3	1	2	1	2	1	-	-
CO2	2	3	1	3	2	3	3	2	3	1	3	1	-	-	-
CO3	2	3	2	-	1	2	2	-	1	2	2	3	1	-	-
CO4	1	-	1	1	1	-	1	3	1	1	1	1	-	-	-
AVG	2	2.7	1.5	1.7	1.25	2.3	1.75	2.7	1.5	1.5	1.75	1.75	1	-	-

Weightage Values: 3 = Strongly matched, 2 = Moderately matched, 1 = Weakly matched, (-) = Not matched.

Course Name: Automotive Electronics

Course Code:EC801C

Contact:3:0:0

Total Contact Hours:36

Credits:3

Prerequisite:Require the primary knowledge about Automotive Electrical & Electronic System.

Course Outcomes:

The Graduates of the ECE program will be able to:

CO1: Obtain an overview of automotive components, subsystems, design cycles, communication protocols and safety systems employed in today's automotive industry.

CO2: Interface automotive sensors and actuators with microcontrollers.

CO3: Develop, Simulate and Integrate control algorithms for ECUs with hardware.

CO4: Understand and explain fundamentals of automotive electrical and electronic systems.

CO5: Apply the various concepts of electrical and electronic to small vehicle system.

CO6: Analyze the design considerations of various engine control systems in automotive electrical and electronics.

Course Content:

Module 1:

[8L]

Overview of Automotive Industry: Leading players, Automotive supply chain, Global challenges, Role of technology in Automotive Electronics and interdisciplinary design, Tools and processes.

Current trends in modern automobiles:

- A. Open and close loop Systems-Components for electronic engine management.
- B. Electronic management of chassis system.
- C. Vehicle motion control.

Introduction to Modern Automotive Systems and need for electronics in automobiles and application areas of electronics systems in modern automobiles:

Spark and Compression Ignition Engines: Ignition systems, Fuel delivery systems, Engine control functions, Fuel control, electronics systems in engines.

Vehicle Braking Fundamentals: Vehicle dynamics during braking, Hydraulic brake system components, Introduction to antilock braking systems.

Batteries: Principles and construction of lead-acid battery. Characteristics of battery, rating capacity and efficiency of batteries.

Steering Control: Steering system basics, Fundamentals of electronically controlled power steering, electronically controlled hydraulic systems and electric power steering systems, Passenger safety and convenience.

Occupant protection systems: Tyre pressure monitoring systems.

Module 2:

[8L]

Introduction to Electronic systems in Automotive: Sensors and Actuators for body electronics, powertrain and chassis systems. Body electronics domain- Automotive alarms, Lighting, Central locking and electric windows, Climatic Control, Driver information, Parking, etc.

Examples of Sensors: Accelerometers, Wheel speed, Brake pressure, Seat occupancy, Engine speed, Steering wheel angle, Vehicle speed, Throttle position, Turbine speed, Temperature, Mass air flow (MAF) rate, Exhaust gas oxygen concentration, Throttle plate angular position, Crankshaft angular position/RPM, Manifold Absolute Pressure (MAP), Differential exhaust gas pressure and Air bag sensors.

Examples of Actuators: Relays, Solenoids and motors. Chassis control systems and Automatic transmission control systems.

Module 3:

[8L]

Communication protocols: Overview of automotive communication protocols, CAN, LIN, Flex Ray, MOST, Ethernet, D2B and DSI, Communication interface with ECUs, Interfacing techniques and Interfacing with infotainment gadgets, Relevance of Protocols such as TCP/IP for automotive applications, Wireless LAN standards such as Bluetooth, IEEE 802.11x communication protocols for automotive applications.

Module 4:

[12L]

Active Safety Systems: ABS, TCS, ESP, Brake assist, etc. **Passive Safety Systems:** Airbag systems, **Advanced Driver Assistance Systems (ADAS):** Combining computer vision techniques as pattern recognition, feature extraction, learning, tracking, 3D visions etc. to develop real-time algorithms able to assist the driving activity. **Examples of Assistance Applications:** Lane Departure Warning, Collision Warning, Automatic Cruise Control, Pedestrian Protection, Headlights Control, Connected Car technology and trends towards Autonomous vehicles.

Functional Safety: Need for safety systems, Safety concept, Safety process for product life cycle, Safety by design, Validation.

Diagnostics: Fundamentals of Diagnostics, Basic wiring system and Multiplex wiring system, Preliminary checks and adjustments, Self-diagnostics system.

Textbooks:

1. Williams. B. Ribbens: "Understanding Automotive Electronics" 6th Edition, Elsevier Science, New publication, 2003.
2. Robert Bosch: "Automotive Electronics Handbook", John Wiley and Sons, 2004.

Reference Books:

1. Ronald K. Jurgen: "Automotive Electronics Handbook", 2nd Edition, McGraw-Hill, 1999. James D. Halderman: "Automotive Electricity and Electronics", PHI Publication.
2. Terence Rybak & Mark Stefika: "Automotive Electromagnetic Compatibility (EMC)", Springer 2004.
3. Allan Bonnick: "Automotive Computer Controlled Systems, Diagnostic Tool and Techniques", Elsevier Science, 2001.
4. Bosch, "Automotive Electrics and Automotive Electronics. System and components, Networking and Hybrid drive", Fifth edition, Springer view 2014.
5. Najamuzzaman, "Automotive Electronics Design Fundamental" first edition, Springer 2015

CO-PO-PSO MAPPING

CO	PO1	PO2	PO3	PO4	PO5	PO6	PO7	PO8	PO9	PO10	PO11	PO12	PSO1	PSO2	PSO3
CO 1	3	1	2	3	2	1	2	3	2	1	1	1	2	3	-
CO 2	3	2	1	2	3	3	2	1	2	1	2	2	3	2	-
CO 3	2	3	2	3	2	1	1	2	3	2	1	1	2	2	-
AVG	2.7	2	1.7	2.7	2.3	1.7	1.7	2	2.3	1.3	1.3	1.3	2.3	2.3	

Weightage Values: (3) = Strongly Matched; (2) = Moderately Matched; (1) = Weakly Matched; (-) = NotMatched.

Course Name: Adaptive Signal Processing

Course Code: EC801D

Contact: 3:0:0

Total Contact Hours: 36

Credit: 3

Course Objectives: The aim of the Adaptive Signal Processing course is to present its algorithms and architectures and explain their use in real world applications. As prerequisites it is assumed that students have studied discrete and continuous signals and systems, and introductory linear algebra.

Course Outcomes:

Graduates of the ECE program will be able to:

CO-1: Learn the concept of adaptive signal processing and its applications.

CO-2: Understand the idea of Wiener filter.

CO-3: Understand LMS and RLS algorithm.

CO-4: Realize Lattice Filters and its realization.

CO-5: Comprehend Kalman Filtering and its applications.

Course Content:

Module-1: Adaptive Filter and Applications: [8L]

Adaptive Systems: Definition and characteristics – Properties, Correlation matrix, Applications and examples of an adaptive system- Adaptive Modelling and System Identification, Inverse Adaptive Modelling, Adaptive Interference Cancelling, telecommunications adaptive equalization, Adaptive Arrays and Adaptive Beamforming.

Module-2: Wiener Filter: [6L]

Wiener filters - Linear optimum filtering - Minimum mean-square error - Wiener-Hopf equations - Multiple linear regression model - Steepest-descent algorithm - Linear prediction - Forward linear prediction, Levinson-Durbin algorithm.

Module-3: LMS and RLS algorithm: [8L]

Least-Mean-Square (LMS) adaptive filters - LMS algorithm, LMS adaptation algorithm, method of steepest descent and its convergence criteria, LMS versions: normalized LMS, leaky, sign, variable step size, transform domain LMS algorithm using DFT and DCT. Block LMS (BLMS) algorithm: frequency domain BLMS (FBLMS), Method of Least Squares - Normal equations and linear least square filters, Recursive least squares (RLS) algorithm.

Module-4: Lattice Filters: [6L]

Forward Linear Prediction, Backward Linear Prediction, Prediction Error Filters, derivation of the Lattice Structure, All-pole Lattice Structure, Pole-Zero Lattice Structure, Adaptive Lattice Structure, Autoregressive modelling.

Module-5: Kalman Filtering: [6L]

Statement of Kalman Filtering Problem, Estimation of State Using Innovation, Variance of Kalman Filtering, Extended Kalman Filtering.

TEXTBOOKS:

1. Simon Haykin, "Adaptive Filter Theory", Pearson Education, Fifth Edition, 2013.
2. Bernard Widrow and Samuel D. Stearns, "Adaptive Signal Processing", Pearson Education, 2001.

REFERENCE BOOKS:

1. Farhang-Boroujeny B., "Adaptive Filters Theory and Applications", John Wiley & Sons, 1st Ed., 1998.
2. John R. Trierchler, C. Richard Johnson (Jr), Michael G. Larimore, "Theory and Design of Adaptive Filters", Prentice Hall India Private Limited, 2004.
3. Ali H. Sayed, "Fundamentals of Adaptive Filtering", Wiley, 1st Ed., 2003.
4. Todd K. Moon, Wynn C. Stirling, "Mathematical Methods and Algorithms for Signal Processing" Prentice Hall, First edition, 1999.

CO-PO-PSO MAPPING

:

CO	PO1	PO2	PO3	PO4	PO5	PO6	PO7	PO8	PO9	PO10	PO11	PO12	PSO1	PSO2	PSO3
CO1	3	1	2	3	2	1	2	3	2	1	1	1	3	2	-
CO2	3	2	1	2	3	3	2	1	2	1	2	2	3	3	-
CO3	2	3	2	3	2	1	1	2	3	2	1	1	3	2	-
CO4	3	1	2	3	2	1	2	3	2	1	1	1	3	3	-
CO5	3	2	1	2	3	3	2	1	2	1	2	2	2	3	-
AVG	2.8	1.8	1.6	2.6	2.4	1.8	1.8	2	2.2	1.2	1.4	1.4	2.8	2.6	-

Weightage Value: **(3)** =Stronglymatched;**(2)**=Moderatelymatched;**(1)** =Weaklymatched;**(-)**=Notmatched.

Course Name: Block Chain

Course Code: EC802A

Contact: 3:0:0

Total Contact Hours: 36

Credits:3

Prerequisite:Cryptography,DataStructure,AdvancedDataStructure,Algorithms.

CourseOutcomes:

Graduatesofthe ECEprogramwillbeableto:

CO1:DefineBlockChainFundamentals.

CO2: AnalyzeBlockchainapplicationsinastructuredmanner

CO3: CreateownCryptotoken.

CO4:Applycryptocurrencyexchangesandwalletssafely.

CO5: Explainlatestadvancesand itsapplicationsinBlock ChainTechnology.

CourseContent:

Module-1:BLOCKCHAININTRODUCTION

[4L]

Blockchain Technology Mechanisms & Networks. Blockchain Origins. Blockchain Objectives, Blockchain Users and Adoption, Blockchain Challenges, Transactions and Blocks, P2P Systems, Keys as Identity, Digital Signatures, Hashes as Addresses, Hash Pointers and Data Structures, Blockchain Transactions.

Module-2:BITCOIN&CRYPTOCURRENCY

[5L]

Bitcoin Fundamentals, The Bitcoin Network. The Bitcoin Mining Process. Mining Developments, Bitcoin Wallets, Decentralization and Hard Forks, Alternative Blockchains/Alt-chains, Ethereum Consensus Mechanisms, How Smart Contracts Work, Difference Between Private Consortium and Public Networks, Ethereum Virtual Machine (EVM), Merkle Tree, Double-Spend Problem, New Developments in Blockchain, Ethereum's Ecosystem and DAPPS (Decentralized applications), Blockchain and Digital Currency, Transactional Blocks, Impact of Blockchain Technology on Cryptocurrency, Cryptography.

Module3: ETHEREUM**[5L]**

Introduction to Ethereum, History of Ethereum, Interfacing with Ethereum Networks, Meta mask Setup. Ethereum Accounts. Receiving Ether, Transaction- Smart Contracts, Our First Contract, Contract Structure, Function Declarations, Testing with Remix, Redeploying Contracts, Behind the Scenes of Deployment, More on Running Functions Than You Want to Know, Gas and Transactions, Mnemonic Phrases, Getting More Ether.

Module4: SOLIDITY PROGRAMMING**[6L]**

Solidity - Language of Smart Contracts, Installing Solidity & Ethereum Wallet, Basics of Solidity by Example: Sub coin Smart Contract, Layout of a Solidity Source File & Structure of Smart Contracts, General Value Types (Int, Real, String, Bytes, Arrays, Mapping, Enum, address), Ether Units, Time Units.

Module5: ETHEREUM CODING FOR BLOCKCHAIN**[6L]**

Globally Available Variables & Functions, Operators: Arithmetic, Logical & Bitwise Operators, Control Structure (if-else, for, while, Do-While), Scoping and Declarations, Input Parameters and Output Parameters, Function Calls & Return Types, Function Modifiers, Fallback Function, Abstract Contract, Creating Contracts via "new" Operator. Inheriting Smart Contracts. Importing Smart Contracts & Compiling Contracts, Events Logging, Exceptions.

Module6: CONTRACT DEPLOYMENT FOR BLOCKCHAIN ENVIRONMENT**[6L]**

Boilerplate Requirements, Project File Walkthrough, Syntax Highlighters, Compiling Solidity, The Compile Script, Testing Architecture, Fetching Accounts from Ganache, Deployment with Web3, Deployed Inbox Overview, Asserting Deployment, Web3 Version Fix, Verifying the Initial Message, Testing Message Updates, Deployment with INFURA, Wallet Provider Setup, Deployment to Rinkeby, Observing Deployment on Etherscan, Deployed Contracts in Remix, Complete Example: Crowd Funding Smart Contract, Complete Example: Voting Ballot Smart Contract.

Module7: INTRODUCTION TO HYPER LEDGER**[4L]**

Hyperledger- Distributed Ledger Technology & its Challenges, Hyperledger & Distributed Ledger Technology, Hyperledger Fabric, Hyperledger Composer.

Textbooks:

1. Antony Lewis, "The Basics of Bitcoins and Blockchains: An Introduction to Cryptocurrencies and the Technology that Powers Them (Cryptography, Crypto Trading, Derivatives, Digital Assets)", Publisher -Mango, September 15, 2018.
2. Daniel Drescher, "Blockchain Basics", Apress; 1st edition, 2017
3. Anshul Kaushik, "Blockchain and Cryptocurrencies", Khanna Publishing House, Delhi.
4. Imran Bashir, "Mastering Block Chain: Distributed Ledger Technology, Decentralization and Smart Contracts Explained", Packt Publishing, first edition - 2012.

ReferenceBooks:

1. Ritesh Modi, "Solidity Programming Essentials: A Beginner's Guide to Build Smart Contracts forEthereumand Block Chain", PacktPublishing.

CO-PO-PSO MAPPING

CO	PO1	PO2	PO3	PO4	PO5	PO6	PO7	PO8	PO9	PO10	PO11	PO12	PSO1	PSO2	PSO3
CO1	2	2	3	1	1	-	-	1	2	1	1	1	2	2	2
CO2	3	3	3	3	1	-	-	1	2	1	1	3	2	3	2
CO3	3	3	3	2	1	-	1	1	2	1	1	3	3	2	2
CO4	3	3	3	1	1	1	-	1	2	1	1	3	2	2	1
AVG	2.8	2.8	3	1.8	1	1	1	1	2	1	1	2.5	2.3	2.3	1.8

Weightage Value: (3) = Strongly matched; (2) = Moderately matched; (1) = Weakly matched; (-) = Notmatched.

Course Name: Deep Learning

Course Code:EC802B

Contact: 3:0:0

Total Contact Hours: 36

Credits: 3

Prerequisite:

Solid background in Statistics, Calculus, Linear Algebra and Probability.

Good Exposure of Python packages like, Numpy, Pandas, Matplotlib, Scikit-learn

Course Outcome(s):

On completion of the course Graduates of the ECE program will be able to:

CO1. Understand the basic concepts in Neural Networks and Deep Learning and applications.

CO2. Understand the Shallow & Deep Neural Networks.

CO3. Understand the Convolutional Neural Network models for Images.

CO4. Understand the Recurrent Neural Network models for Sequenced data.

Course Content:

Module1: Introduction to Neural Networks and Deep Learning [9L]

Neural Network, Supervised Learning with Neural Networks, Deep Learning, Binary Classification, Logistic Regression, Gradient Descent, Derivatives, Computation Graph, Derivatives with a Computation Graph, Vectorization, Vectorizing Logistic Regression, Vectorizing Logistic Regression's Gradient Output.

Module2: Shallow Neural Network & Deep Neural Network [9L]

Neural Networks Overview, Neural Network Representation, computing a Neural Network's

Output, Vectorizing Across Multiple Examples, Activation Functions, Gradient Descent for Neural Networks, Backpropagation Intuition, Random Initialization, Deep Layer Neural Network, Forward Propagation in a Deep Network, Building Blocks of Deep Neural Networks, Forward and Backward Propagation, Parameters vs Hyperparameters.

Module 3: Foundations of Convolutional Neural Networks

[9L]

The Basic Structure of a Convolutional Network, The Convolution Operation, Motivation, Pooling, Convolution and Pooling as an Infinitely Strong Prior, Variants of the Basic Convolution Function, Structured Outputs, Data Types, Random or Unsupervised Features, Training a Convolutional Network, Object Localization and Object Detection, YOLO Algorithm, Case Studies of Convolutional Architectures-Alex Net, VGG, Google Net, Res Net, Applications of Convolutional Networks.

Module 4: Sequence Models

[9L]

Unfolding Computational Graphs, Recurrent Neural Networks, Bidirectional RNNs, Encoder-Decoder Sequence-to-Sequence Architectures, Deep Recurrent Networks, Recursive Neural Networks, The Challenge of Long-Term Dependencies, Echo State Networks, Long Short-Term Memory (LSTM), Gated Recurrent Units (GRUs), Optimization for Long-Term Dependencies, Explicit Memory, Applications of Recurrent Neural Networks.

CO-PO-PSO MAPPING

CO	PO1	PO2	PO3	PO4	PO5	PO6	PO7	PO8	PO9	PO10	PO11	PO12	PSO1	PSO2	PSO3
CO1	1	2	3	3	3	-	-	-	-	1	2	1	-	-	1
CO2	-	2	2	2	1	-	-	-	-	-	1	-	-	-	-
CO3	1	2	3	3	3	1	-	-	-	2	-	1	-	-	1
CO4	3	2	2	2	1	1	-	-	-	3	2	3	-	-	1
AVG	1.7	2	2.5	2.5	2	1				2	1.7	1.7			1

Weightage Value: (3) = Strongly matched; (2) = Moderately matched; (1) = Weakly matched; (-) = Not matched.

Course Name: Biology for Engineers

Course Code: EC802C

Contact: 3:0:0

Total Contact Hours: 36

Credits: 3

Course Outcomes:

Graduates of the ECE program will be able to:

CO1: Understand the biological concepts from an engineering point of view.

CO2: Understand the concepts of biological sensing and its challenges.

CO3: Understand the process of human physiological system.

CO4: Integrate biological principles for developing next generation technologies.

CO5: Understand the Design of modern equipment and devices in bioengineering.

CO6: Understand the application of engineering principles and design concepts to medicine and biology for healthcare purposes.

Course Contents:

MODULE 1: [8L]

What is the need to study Biology – Significance of Life Science Studies - Different Inventions inspired by Biology - In Next Generation Technology Development importance of Biology – Cell: Structure, Potential-Action Potential – ECG, EMG, EEG, EOG and other common signals – concept of Ergonomics.

MODULE 2: [5L]

Biomechanics: What is the Terminology, Anthropometry, Skeletal Mechanics: Concept of Structure of bones, Different properties and compositions of bones and relationship with the structure, Properties of bones: Elastic, Biomechanical activity: Mathematical modelling.

MODULE 3: [3L]

Active muscle: Mechanics, Details of force production and transmission of Muscle, Functional relations between Force length and Force Velocity curves.

MODULE 4: [3L]

Potassium channels, Function of Neuron, Concept of Central Nervous Systems, Artificial

Neural Networks, techniques of Machine Learning.

MODULE5: [4L]

Different Sensing Techniques: Working principle of Sense organs, Mechanisms of Sensing Issues on Sensor Development, Discussion on Digital Camera: Eye Comparison, electronic nose, electronic tongue, electronicskin.

MODULE6: [3L]

Devices on Physiological Assist: Different Artificial Organ Development like Kidney, Liver, Pancreas, heart valves – What are the design Challenges and Developments in technology.

MODULE7: [10L]

Health Care 4.0 - Biology oriented research and development in engineering domain, Discussion on different topics: The Internet of Medical Things (IoMT) & Bio Machine Learning. Artificial Intelligence and Bio Intelligence, Modern Biomedical Sensors and Biochip, Biomedical Control System & Robotics, BioBigData, In Biomedical field the process of Product Design & Commercialization.

Textbooks/References:

1. Leslie Cromwell, Biomedical Instrumentation, Prentice Hall 2011.
2. Thyagarajan S., Selvamurugan N., Rajesh M.P., Nazeer R.A., Thilagaraj W., Barathi S., and Jaganthan M.K., Biology for Engineers, Tata McGraw-Hill, New Delhi, 2012.
3. Fanwen Meng, Albert Tan, Janya Chanchaichujit, Sarayoot Eaimkhong, Healthcare 4.0: Next Generation Processes with the Latest Technologies, Springer, 23-Jul-2019-Science.
4. Jeremy M. Berg, John L. Tymoczko and Lubert Stryer, "Biochemistry", W.H. Freeman and Co. Ltd., 6th Ed., 2006.
5. Eric R. Kandel, James H. Schwartz, Thomas M. Jessell, "Principles of Neural Science", McGraw-Hill, 5th Edition, 2012.

CO-PO-PSO MAPPING

CO	PO1	PO2	PO3	PO4	PO5	PO6	PO7	PO8	PO9	PO10	PO11	PO12	PSO1	PSO2	PSO3
CO1	2	2	-	-	-	2	-	-	-	-	-	-	-	-	-
CO2	1	2	-	-	-	2	-	-	-	-	-	1	-	-	-
CO3	2	2	3	1	-	2	2	-	-	-	-	-	-	-	-
CO4	3	1	3	1	3	3	-	-	-	-	-	-	-	-	-
CO5	2	2	2	1	3	2	-	-	-	-	-	-	-	-	-
CO6	3	2	2	1	-	2	2	-	-	-	-	-	-	-	-
AVG	2.2	1.82	2.5	1	3	2.2	2	-	-	-	-	-	-	-	-

Weightage Value: (3) = Strongly matched; (2) = Moderately matched; (1) = Weakly matched; (-) = Not matched.

Course Name: Foreign Language

CourseCode:EC802D

Contact:3:0:0

Total Contact Hours:36

Credits:3

French (Open Elective)

Pre-requisites: Basic high school level reading, writing and communication skills in English.

Course outcomes: By the end of the course the students will be able to

CO1: Read basic French and interpret the meaning

CO2:Construct simple sentences in French

CO3:Interact with others and hold simple conversations in French

CO4:Demonstrate a basic knowledge of French culture, manners, geography and world view

Course Content

Unit1

6L

Vocabulaire

- L' alphabet français (The Alphabets)
- Les nombres (cardinaux et ordinaux) (Numbers)
- Les mois de l'année (The Months of the Year)
- Les saisons (The Seasons)
- Les jours de la semaine (The Days of the Week)
- Les couleurs (The Colours)
- La famille (The Family)
- Les nationalités (The Nationalities)

Grammaire

- Les Verbes—*être, avoir et aller*
- Nouns—Gender and Number
- Les articles (définis, indéfinis, contracté et partitif)
- Les adjectifs—possessifs et démonstratifs

Français Interactif (Listening and Speaking)

- Les salutations
- Les formes de politesse
- Présentez-vous (About Yourself)

Unit 2**6L***Vocabulaire*

- L'heure (the time)
- La maison (the house)
- Le corps (the body)
- Les vêtements (clothes)
- Les professions (professions)
- Les loisirs (pastimes)
- Le sport (Sports)

Grammaire

- Les Verbes—*voir, savoir, venir, aller, sortir, connaître, partir.*
- Les négations
- Le futur
- Les interrogatifs

Français Interactif (Listening and Speaking)

- Décrivez les images
- La dictée
- Liséz le journal

Unit3**6L***Vocabulaire*

- La nourriture (Food)
- Les repas (Meals)
- Les légumes (Vegetables)
- Les fruits (Fruits)
- Les fleurs (Flowers)
- Les animaux (Animals)
- Les oiseaux (Birds)

Grammaire

- Les adverbes
- Les adjectifs
- Les prépositions

Français Interactif (Listening and Speaking)

- Ecoutez la radio/la télévision
- Dialogues—À la médecin, au café, a la gare

Unit 4**6L***Vocabulaire*

- Le jardin (The Garden)

- Le temps (the weather)
- Les voyages (Travel)
- La ville (the City)
- Les vacances (Holidays)

Grammaire

- Pronoms interrogatifs
- Mood—subjonctif et l'impératif

Français Interactif (Listening and Speaking)

- Se présenter (expressing ideas/opinions on general topics)
- Ecoutez le programme sur la radio/la télévision

Unit 5

6L

Vocabulaire

- Les modes de transport (Transport)
- L'Ecole (the School)
- À la Campagne (in the Country)
- À la restaurant (at the Restaurant)
- Le Cinema (at the Cinema)
- La Marché (at the Market)

Grammaire

- Passé Composé
- Passé Récent

Ecrivez en Français (Writing)

- Décrivez votre ville
- Décrivez votre maison/appartement
- Qu'est que son métier?

Unit 6

6L

En France

- Les villes de France (the Cities of France)
- Les montagnes et rivières de France (Mountains and Rivers)
- La géographie de France (Geography of France)
- La gastronomie française (French Food and Gastronomy)
- Les fêtes (Festivals of France)

Grammaire

- Les Verbes Pronominaux
- Les Pronoms Personnels

Ecrivez en Français (Writing)

- Décrivez votre vacation à l'mer
- Quels sont les loisirs préférés?
- Les magasins de supermarché

Text Books:

1. *Le Nouveau Sans Frontières-1* (Paris: CLE International, 1999)
2. *Dondo, Modern French Course* (1930, Oxford:Oxford UP, 1999)

3. Dictionnaire Larousse

CO-PO-PSO MAPPING

	PO1	PO2	PO3	PO4	PO5	PO6	PO7	PO8	PO9	P10	P11	P12
CO1	2	-	-	3	-	3	2	2	3	3	-	3
CO2	2	3	3	3	-	3	3	3	2	3	-	3
CO3	1	3	3	3	-	2	2	2	2	3	-	2
CO4	1	-	-	-	-	2	2	2	2	3	-	3
Avg	1.5	3	3	3		2.5	2.25	2.25	2.25	3		2.75

Course Name: Product Design & Manufacturing Processes

Course Code:EC802E

Contact: 3:0:0

Total ContactHours:36

Credits:3

Prerequisite:The student should have completed two semesters of UG Engineering or Science program.Awarenessof toolsandmethodsfor productdesign anddevelopment.

Industry Support: All the industries involved in product conceptualization, design and development likeMSME, HAL,SAIL, ISROetc.

CourseOutcomes:

GraduatesoftheECEprogram willbeableto:

CO1.Understandthe product designanddevelopmentprocess.

CO2.Applycreativethinkingskillsforideageneration.

CO3.Translateconceptualideasintoproducts.

CO4.Presentideasusingvarioustypesof models.

CourseContent:

Module 1: [9L]

Introduction to product design and Manufacturing, Fundamentals of Manufacturing towards ProductDevelopment, Engineering Design, Process Product design morphology and Characteristics ofsuccessful product development, Design and development of products, duration and cost of productdevelopment, the challenges ofproductdevelopment.DevelopmentProcesses and

Organizations, the front-end process, adopting the generic product development process, the AMF development process, product development organizations, the AMF organization.

Module 2: [8L]

Product Planning: The product planning process, identify opportunities. Evaluate and prioritize projects, allocate resources and plan timing, complete pre project planning, reflect all the results and the process.

Identifying Customer Needs: Translating Customer Needs, gather raw data from customers, interpret raw data in terms of customer needs, organize the needs into a hierarchy, establish the relative importance of the needs and reflect on the results and the process. Value Engineering, an introduction

Module 3: [6L]

Product Specifications: What are specifications, when are specifications established, establishing target specifications, setting the final specifications.

Concept Generation: The activity of concept generation, clarify the problem, search externally, search internally, explore systematically, reflect on the results and the process. Concept Selection, Overview of methodology, concept screening, and concept scoring,

Module 4: [7L]

Concept Testing:

Define the purpose of concept test, choose a survey population, choose a survey format, communicate the concept, measure customer response, interpret the result, reflect on the results and the process.

Industrial Design: Assessing the need for industrial design, the impact of industrial design, industrial design process, managing the industrial design process and assessing the quality of industrial design.

Module 5: [6L]

Visual Design, Elements of Visual Design and Quality Function Deployment (QFD), Quality Control, Quality Assurance.

Design for Manufacturing: Definition, estimation of manufacturing cost, reducing the cost of components, assembly, supporting production, impact of DFM on other factors. Prototyping, Prototyping basics, principles of prototyping, technologies, planning for prototypes.

Textbooks:

1. Eppinger, S. and Ulrich, K., 2015. Product design and development. McGraw-Hill Higher Education.
2. Magrab, E.B., Gupta, S.K., McCluskey, F.P. and Sandborn, P., 2009. Integrated product and process design and development: the product realization process. CRC Press.
3. Product Design and Manufacturing - AC Chitale and RC Gupta, PH1, -3rd Edition, 2003.
4. Product Design for Manufacture and Assembly, G. Boothroyd, P. Dewhurst, W. Knight, Marcel Dekker, University of Rhode Island Kingston, New York, USA

Reference Books and materials:

1. Boothroyd, G., 1994. Product design for manufacture and assembly. Computer-Aided Design, 2.26(7).
2. Product Design and Development, Karl T. Ulrich, Steven D. Eppinger, McGraw-Hill companies, New York, USA.
3. Design for Manufacturability Handbook, James G. Bralla, McGraw-Hill companies, New York, USA.
4. Manufacturing Processes: Casting, Forming and Welding: H.S. Shan, Cambridge University Press.
5. <https://ocw.mit.edu/courses/mechanical-engineering/2-008-design-and-manufacturing-ii-spring-2004/lecture-notes/>
6. New Product Development - Tim Jones. Butterworth Heinemann - Oxford. UCI-1997

CO-PO-PSO MAPPING

CO	PO1	PO2	PO3	PO4	PO5	PO6	PO7	PO8	PO9	PO10	PO11	PO12	PSO1	PSO2	PSO3
CO1	2	3	1	-	-	-	-	-	-	-	-	-	-	-	-
CO2	3	2	1	2	2	2	-	-	-	-	-	-	-	-	-
CO3	2	3	3	3	2	1	-	-	-	-	-	-	-	-	-
CO4	3	2	3	2	3	2	-	-	-	-	-	-	-	-	-

Weightage Value: (3) = Strongly matched; (2) = Moderately matched; (1) = Weakly matched; (-) = Not matched.

Course Name: Business Research Method

Coursecode:EC802F

Contact: 3:0:0

Total ContactHours:36

Credit:3

Prerequisite:

Reasoningandanalyticalability.

Courseoutcomes:

TheGraduatesofthe ECEprogramwill beableto:

CO1: Understand various kinds of research, objectives of doing research, research processresearchdesignsand sampling.

CO2:Formulateresearch problemanddevelopasufficientlycoherentresearchdesign.

CO3:Developbasicknowledgeonqualitative,quantitativeaswellasmeasurement&scalingtechniques.

CO4:Capableofwritinganddevelopingindependentthinkingforcriticallyanalyzingresearchreports.

CourseContents:

Module-1:Introduction

2L

Research:–Definition,Meaning,Importance,ResearchProcess

Module-2:ResearchDesign

4L

Research design: Concept, Features of a good research design, Concept of Cross-sectionaland Longitudinal Research. Experimental Design: Concept of Cause, Causal relationships,Concept of Independent&Dependentvariables,extraneousvariable, Treatment,Controlgroup.

Module-3:DatacollectionandPresentation

4L

Primary Data-observational method, Interview, Questionnaire, Survey; Secondary data-internalandexternalsources,QuestionnaireConstruction,Validity,andreliabilitytest.Datapresentation-FrequencyDistributionCharts.

Module-4:ReviewofstatisticalMeasures:

4L

Measures of Central Tendency, Dispersion, Skewness, Correlation and regression

Module-5: Scaling & measurement techniques

6L

Concept of Measurement: Need of Measurement Problems in measurement in management research – Validity and Reliability. Levels of measurement – Nominal, Ordinal, Interval, Ratio. Concept of Scale – Rating Scales viz. Likert Scales, Semantic Differential Scales, Constant Sum Scales, Graphic Rating Scales – Ranking Scales – Paired comparison & Forced Ranking – Concept and Application.

Module-6: Sampling Methods & Distributions

4L

Sampling and sampling distributions: Sampling methods, sampling distribution, Central limit theorem, Confidence Interval Estimation, Determination of sample size

Module-7: Hypothesis testing

8L

Concept of Hypothesis & Hypothesis Testing (one sample test and two sample tests). Test of Significance: Small sample tests: t (Mean, proportion) and F tests, Z test, Analysis of Variance: One-way and two-way

Classifications, Chi-square test; Interpretation of the given data and report preparation.

Module-8

4L

Multivariate Data Analysis: Factor Analysis, Multi-Dimensional Scaling.

References:

1. C.R Kothari, "Research Methodology, Methods & Technique"; New Age International Publishers, 2004.
2. R.Ganesan, "Research Methodology for Engineers", MJ Publishers, 2011.
3. Y.P. Agarwal, "Statistical Methods: Concepts, Application and Computation", Sterling Pubs., Pvt., Ltd., New Delhi, 2004.
4. D.R. Cooper and P.S. Schindler: Business Research Methods, Tata McGraw-Hill.
5. J.K. Das: Business Mathematics and Statistics: Academic Publishers.
6. P. Mishra: Business Research Methods, Oxford University Press.

CO-PO-PSO MAPPING

CO	PO1	PO2	PO3	PO4	PO5	PO6	PO7	PO8	PO9	PO10	PO11	PO12	PSO1	PSO2	PSO3
CO 1	-	-	-	-	2	2	3	-	3	-	3	3	-	-	-
CO 2	-	-	-	-	-	2	-	2	3	3	-	3	-	-	-
CO 3	-	-	-	-	2	3	-	-	3	3	-	2	-	-	-
CO 4	-	-	-	-	-	3	2	-	3	3	-	2	-	-	-

Weightage Values: 3 = Strongly matched, 2 = Moderately matched, 1 = Weakly matched, (-) = Notmatched.

Stream: ECE

Subject Name: MajorProject-II

Subject Code: PR891

Contact hour: 12P

Total contact hour- 120

Credits: 6

Prerequisite: Course completed up to 7th semester in UG ECE

Course Objective:

Prepare students with foundation knowledge in a project domain through surveying, designing, implementing, observing and reporting.

Methodology:

6. Thinking: Discussion on innovative idea.
7. Exploring: Survey of recent research.
8. Implementing: Project guidance to basic prototype implementation.
9. Documenting: Guidance on reporting and conference paper writing.

Each MajorProject –II group should submit the following under their semester project report submission

6. Title, certificates, declaration by student, acknowledgement, Table of Contents, abstract, keywords, Introduction, Literature Survey, System Analysis (if applicable), System Design (if applicable), Coding, Testing (if applicable), Conclusion, Future Scope of work, reference

Course outcome:

Sem. No.	Course Title (Code)	CO Codes	Course Outcomes
			On completion of the course students will be able to
8 th	Major Project-II(PR891)	CO1	Apply the knowledge acquired through survey of recent research to set the project goal.
		CO2	Distinguish the way of implementation of prototype
		CO3	Identify the fault issue through various case study
		CO4	Implement the prototype using modern tools
		CO5	Demonstrate the project design to share the idea through conference/workshop/seminar etc.
		CO6	Modify the project design for the benefit to societal issues

CO-PO-PSO MAPPING

	PO1	PO2	PO3	PO4	PO5	PO6	PO7	PO8	PO9	PO10	PO11	PO12	PSO1	PSO2	PSO3
CO1	3	3	3	2	1	1	3		1	1		3	2	3	
CO2	3	3	3	3	3			3	3		2	3	3	3	2
CO3	2		3	3	2	2	3	3	2	2		3	3	2	1
CO4	1	3	3	2	3		3	2	3		2	3	3	3	3
CO5	3		2	3	3	2		3	3	2		3	3	3	2
CO6	3	3	3	2		2	3			2		3	2		3
AVG	2.5	3	2.83	2.5	2.4	1.75	3	2.75	2.4	1.75	2	3	2.67	2.8	2.2

Stream: ECE

Subject Name: Grand Viva

Subject Code: PR892

Contact hour: - 2P

Total contact hour- 20

Credits: 1

Prerequisite: Course completed up to 7th semester in UG ECE

Objective: The objective of comprehensive viva-voce is to assess the overall knowledge of the student in the relevant field of Engineering acquired over 4 years of study in the undergraduate program.

Contents: The viva shall normally cover the subjects taught in all the semesters of B.Tech Programme.

Learning Outcomes: Viva will be conducted in 8th semester which will be covering the complete syllabus. This will test the student's learning and understanding during the course of their B.Tech programme. In doing so, the main objective of this course is to prepare the students to face interview both in the academic and the industrial sector.

Examination: Every student will be required to undergo comprehensive viva-voce at the end of 8th semester of B.Tech Programme. The duration of the viva will range from 15-30 min. The examination committee will be constituted by the HoD and consist of at least three faculty members.

Course outcome:

Sem. No.	Course Title (Code)	CO Codes	Course Outcomes
			On completion of the course students will be able to
8 th	Grand Viva (PR892)	CO1	Demonstrate the concept of engineering topic in the field of electronics and communication engineering
		CO2	Identify the question and deliver the adequate answer

	CO3	Distinguish the way answering a topic
	CO4	Unveil the ability to listen and answer the topic
	CO5	Exhibit deep attention to receive feedback after answering
	CO6	Give attention to the societal context during the answers and approaches.

CO-PO-PSO MAPPING:

Sem. No.	Course Title (Code)	CO Codes	Program Outcomes (POs)															
			PO1	PO2	PO3	PO4	PO5	PO6	PO7	PO8	PO9	PO10	PO11	PO12	PSO1	PSO2	PSO3	
8 th	Grand Viva (PR892)	CO.PR892.1	3	3	3	2	1	1	3		1	1		3	2	3		
		CO.PR892.2		3		3	3			3			2	3	3	3	2	
		CO.PR892.3	2		3	3		2	3		2	3	1		3	2	1	
		CO.PR892.4	2	3	3	2	3			2	3		2	3	3	2	3	
		CO.PR892.5	1	3		3		2		3	3	2		1	3	1	2	
		CO.PR892.6	3	3	3	2		2	3			2		3				3

CO-PO-PSO MAPPING

	PO1	PO2	PO3	PO4	PO5	PO6	PO7	PO8	PO9	PO10	PO11	PO12	PSO1	PSO2	PSO3
CO1	3	3	3	2	1	1	3		1	1		3	2	3	
CO2		3		3	3			3			2	3	3	3	2
CO3	2		3	3		2	3		2	3	1		3	2	1
CO4	2	3	3	2	3			2	3		2	3	3	2	3
CO5	1	3		3		2		3	3	2		1	3	1	2
CO6	3	3	3	2		2	3			2		3			3
AVG	2.2	3	3	2.5	2.33	1.75	3	2.67	2.25	2	1.67	2.6	2.8	2.2	2.2

Course Name: Essence of Indian Knowledge Tradition

Course Code: MC801

Contacts: 3:0:0

Total Contact Hours: 36

Credits: 3

Prerequisite:

The students to whom this course will be offered must have the knowledge about Indian history, culture and sociological structure.

Course Outcomes:

The Graduates of the ECE program will be able to:

CO1: Identify the concept of Traditional knowledge and its importance.

CO2: Explain the connection between Modern Science and Indian Knowledge System.

CO3: Understand the importance of Yoga for healthcare.

CO4: Interpret the effect of traditional knowledge on environment.

Course Contents:

Module-1: Basic structure of Indian Knowledge System:

[8L]

Define traditional knowledge, nature and characteristics, scope and importance, kinds of traditional knowledge, Indigenous Knowledge (IK), characteristics, traditional knowledge vis-a-vis indigenous knowledge, traditional knowledge Vs western knowledge, traditional knowledge

Module-2: Modern Science and Indian Knowledge System:

[8L] Systems of traditional knowledge protection, Legal

concepts for the protection of traditional knowledge, Patents and traditional knowledge, Strategies to increase protection of traditional knowledge

Module-3: Yoga and Holistic Healthcare: [4L]

Yoga for positive health, prevention of stress related health problems and rehabilitation, Integral approach of Yoga Therapy to common ailments.

Module-4: Traditional Knowledge and Environment: [4L]

Traditional knowledge and engineering, Traditional medicine system, Importance of conservation and sustainable development of environment, Management of biodiversity

Textbooks:

1. V.Sivaramakrishnan (Ed.), Cultural Heritage of India-course material, Bharatiya Vidya Bhavan, Mumbai. 5th Edition, 2014
2. Swami Jitatmanand, Modern Physics and Vedant, Bharatiya Vidya Bhavan.
3. Swami Jitatmanand, Holistic Science and Vedant, Bharatiya Vidya Bhavan.
4. Fritz of Capra, The Wave of life.
5. VN Jha (Eng. Trans.), Tarkasangraha of Annam Bhatta, International Chinmay Foundation, Velliarnad, Arnakulam.
6. Yoga Sutra of Patanjali, Ramakrishna Mission, Kolkata.
7. RN Jha, Yoga-darshanam with Vyasa Bhashya, Vidyanidhi Prakashan, Delhi 2016
RN Jha, Science of Consciousness Psychotherapy and Yoga Practices, Vidyanidhi Prakashan, Delhi 2016.

CO-PO-PSO MAPPING

CO	PO1	PO2	PO3	PO4	PO5	PO6	PO7	PO8	PO9	PO10	PO11	PO12
CO1	3	2	1	-	2	1	-	-	-	2	3	3
CO2	3	2	-	1	3	2	-	1	2	-	3	3
CO3	3	2	2	-	2	3	1	-	2	1	3	3
CO4	3	1	-	2	-	-	-	2	-	3	3	3

Weightage Values: 3 = Strongly matched, 2 = Moderately matched, 1 = Weakly matched, (-) = Notmatched.
