

Curriculum– R23

B.Tech in Mechanical Engineering

Effective for 2023 Admission Batch Onwards

**L – Lecture; T- Tutorial; P- Practical
[1L=1Cr, 1T=1Cr, 1P =0.5 Cr]**

First Year First Semester

Sl. No.	Category	Course Code	Course Title	Hours per week				Credits
				L	T	P	Total	
A. THEORY								
1	Major	ME101	Engineering Mechanics	3	0	0	3	3
	Minor	EE(ME)101	Basic Electrical and	3	0	0	3	3
2	Multidisciplinary	PH(ME)101	Engineering Physics	3	0	0	3	3
3	Multidisciplinary	M(ME)101	Engineering Mathematics –I	3	0	0	3	3
4	VAC	HU104	Environmental science	2	0	0	2	2
5	VAC	HU105	Indian Knowledge System	1	0	0	1	1
B. PRACTICAL								
1	Major	ME191	Engineering Graphics and Design Lab	0	0	3	3	1.5
2	Minor	EE(ME)191	Basic Electrical and Electronics Engineering Lab	0	0	3	3	1.5
3	Ability Enhancement Course	HU(ME)192	Design Thinking and Prototyping	0	0	2	2	1
4	Skill Enhancement Course	PH(ME)191	Engineering Physics Lab	0	0	3	3	1.5
5	Skill Enhancement Course	HU(ME)191	Technical Report Writing & Language Lab	0	0	3	3	1.5
TOTAL CREDIT								22

*‘Mandatory Additional Requirement’(MAR) activities have to be carried out as per university guidelines

First Year 2nd Semester

Sl. No.	Category	Course Code	Course Title	Hours per week				Credits
				L	T	P	Total	
THEORY								
1	Major	ME201	Fluid Mechanics	3	0	0	3	3
2	Multidisciplinary	M(ME)201	Engineering Mathematics II	3	0	0	3	3
3	Multidisciplinary	CH(ME)201	Engineering Chemistry	2	0	0	2	2
4	Ability Enhancement Course	HU201	Professional Communication	2	0	0	2	2
5	VAC	HU202	Values & Ethics	2	0	0	2	2
6	VAC	HU203	Constitution of India	1	0	0	0	1
PRACTICAL								
1	Major	ME291	Workshop and Manufacturing Practices Lab	0	0	3	3	1.5
2	Ability Enhancement Course	HU291	Professional Communication Lab	0	0	2	2	1
3	Skill Enhancement Course	ME292	AutoCAD Lab	0	0	3	3	1.5
4	Skill Enhancement Course	CH(ME)291	Engineering Chemistry Lab	0	0	2	2	1
TOTAL CREDIT								18

*'Mandatory Additional Requirement'(MAR) activities have to be carried out as per university guidelines.

2nd Year 1st Semester

Sl. No.	Category	Course Code	Course Title	Hours per week				Credits
				L	T	P	Total	
THEORY								
1	Major	ME301	Engineering Thermodynamics	3	0	0	3	3
2	Major	ME302	Strength of Material	3	0	0	3	3
3	Major	ME303	Manufacturing Process	3	0	0	3	3
4	Minor	M301	Mathematics III	3	0	0	3	3
5	Minor	CS(ME)301	Computer Fundamentals and Programming	3	0	0	3	3
PRACTICAL								
1	Major	ME391	Material Testing Lab	0	0	3	3	1.5
2	Major	ME392	Manufacturing Process Lab	0	0	3	3	1.5
3	Ability Enhancement Course	HU(ME)391	Technical Seminar Presentation	0	0	1	1	0.5
4	Skill Enhancement Course	CS(ME)391	Computer Fundamentals and Programming Lab	0	0	3	3	1.5
TOTAL CREDIT								20

*‘Mandatory Additional Requirement’(MAR) activities have to be carried out as per university guidelines.

2nd Year 2nd Semester

Sl · N o.	Category	Course Code	Course Title	Hours per week				Credits
				L	T	P	Total	
THEORY								
1	Major	ME401	Applied Thermodynamics	3	0	0	3	3
2	Major	ME402	Fluid Machinery	3	0	0	3	3
3	Major	ME403	Manufacturing Technology	3	0	0	3	3
4	Major	ME404	Materials Engineering	3	0	0	3	3
5	Minor	CS(ME)405	Data Structure	2	0	0	2	2
6	Minor	EC(ME)401A	Microprocessor in Automation	3	0	0	3	3
		EE(ME)401B	Gas Dynamics & Jet Propulsion					
		CS(ME)401C	Internet of Things					
PRACTICAL								
1	Major	ME491	Fluid Mechanics & Fluid Machines Lab	0	0	3	3	1.5
2	Major	ME492	Machine Drawing	0	0	3	3	1.5
3	Major	ME493	Manufacturing Technology Lab	0	0	3	3	1.5
4	Ability Enhancement Course	HU(ME)491	Quantitative Aptitude	1	0	0	1	0.5
TOTAL CREDIT								22

*'Mandatory Additional Requirement'(MAR) activities have to be carried out as per university guidelines.

3rd Year 1st Semester

Sl. No.	Category	Course Code	Course Title	Hours per week				Credits
				L	T	P	Total	
THEORY								
1	Major	ME501	Heat Transfer	3	0	0	3	3
2	Major	ME502	Kinematics & Dynamics of Machines	3	0	0	3	3
3	Major	ME503	A. Refrigeration and Air Conditioning B. Finite Element Analysis C. Metrology & Measurement	3	0	0	3	3
4	Minor	EC(ME)501A	Mechatronics Systems	3	0	1	4	4
		EE(ME)501B	Fluid Power control					
		CS(ME)501C	Data Base Management System					
PRACTICAL								
1	Major	ME591	Heat Transfer Lab	0	0	3	3	1.5
2	Major	ME592	Kinematics & Dynamics of Machines Lab	0	0	3	3	1.5
3	Major	ME593	A. Refrigeration and Air Conditioning Lab B. Finite Element Analysis Lab C. Metrology & Measurement Lab	0	0	3	3	1.5
4	Minor	EC(ME)591A	Mechatronics Systems Lab	0	0	2	2	1
		EE(ME)591B	Fluid Power Control Lab					
		CS(ME)591C	Data Base Management System Lab					
5	Ability Enhancement Course	HU(ME)591	Soft Skill -I	1	0	0	1	0.5
6	VAC	ME594	Modeling & Simulation of Mechanical Systems	0	0	2	2	0.5
7	Project	ME581	Minor Project I	0	0	2	2	1
TOTAL CREDIT								20.5

*'Mandatory Additional Requirement'(MAR) activities have to be carried out as per university guidelines.

3rd Year 2nd Semester

Sl. No.	Category	Course Code	Course Title	Hours per week				Credits
				L	T	P	Total	
THEORY								
1	Major	ME601	IC Engine & Hybrid Vehicles	3	0	0	3	3
2	Major	ME602	Design of Machine Elements	3	0	0	3	3
3	Major	ME603	A. Power Plant Engineering B. Computational Fluid Dynamics C. Tribology	3	0	0	3	3
4	Minor	EC(ME)601A	Robotics	3	1	0	4	4
		EE(ME)601B	Electrical Machines					
		CS(ME)601C	Artificial Intelligence & Machine Learning					
PRACTICAL								
1	Major	ME691	Thermal Engineering Lab	0	0	3	3	1.5
2	Major	ME692	Design Lab	0	0	3	3	1.5
3	Minor	EC(ME)691A	Robotics Lab	0	0	0	2	1
		EE(ME)691B	Electrical Machines Lab					
		CS(ME)691C	Artificial Intelligence & Machine Learning Lab					
4	Ability Enhancement Course	HU(ME)691	Soft Skill-II	1	0	0	1	0.5
5	Internship	ME681	Industrial Training (Min. 2 weeks)	0	0	0	0	1
6	Project	ME682	Minor Project II	0	0	2	2	1
TOTAL CREDIT								19.5

*'Mandatory Additional Requirement'(MAR) activities have to be carried out as per university guidelines.

4th Year 1st Semester

Sl. No.	Category	Course Code	Course Title	Hours per week				Credits
				L	T	P	Total	
THEORY								
1	Major	ME701	Advanced Manufacturing Technology	3	0	0	3	3
2	Major	ME702	A. Automobile Engineering B. Computer Aided Design C. Turbomachinery	3	0	0	3	3
3	Major	ME703	A. Materials Handling B. Design of Transmission Systems C. Nuclear Power Generation & Supply	3	0	0	3	3
4	Minor	EC(ME)701A	3D Printing and Design	3	1	0	4	4
		EE(ME)701B	Electric Vehicles					
		CS(ME)701C	Cyber Security and Blockchain					
5	Multidisciplinary	HU(CS)701	Economics for Engineers	1	0	0	1	1
PRACTICAL								
1	Major	ME791	Advanced Manufacturing Technology Lab	0	0	2	2	1
2	Major	ME792	A. Automobile Engineering Lab B. Computer Aided Design Lab C. Turbomachinery Lab	0	0	2	2	1
3	Ability Enhancement Course	HU(ME)791	Seminar & Group Discussion	0	0	2	2	1
4	Internship	ME781	Internship (Min. 1 month)	0	0	0	0	1
5	Project	ME782	Major Project-I	0	0	8	8	4
TOTAL CREDIT								22

*‘Mandatory Additional Requirement’(MAR) activities have to be carried out as per university guidelines.

4th Year 2nd Semester

Sl. No.	Category	Course Code	Course Title	Hours per week				Credits
				L	T	P	Total	
THEORY								
1	Major	ME801	A. Micro and Nano Manufacturing B. Maintenance Engineering C. Composite Materials	3	0	0	3	3
2	Major	ME802	A. Renewable Energy System B. Industrial Safety C. Nanotechnology	3	0	0	3	3
3	Minor	ECS(ME)801A	Industrial Instrumentation	3	0	0	3	3
		EE(ME)801B	Energy Conservation & Management					
		CS(ME)801C	Data Science and Industry 4.0					
4	Ability Enhancement Course	HU(ME)801	Industrial Management	2	0	0	2	2
PRACTICAL								
1		ME881	Grand Viva	0	0	0	0	1
2	Project	ME882	Major Project-II	0	0	12	12	6
TOTAL CREDIT								18

*‘Mandatory Additional Requirement’(MAR) activities have to be carried out as per university guidelines.

Total Credit:

Semester	Without MOOCS
1st	22
2nd	18
3rd	20
4th	22
5th	22.5
6th	19.5
7th	22
8th	18
TOTAL	162

...

Semester	Minor in INDUSTRIAL AUTOMATION AND CONTROL	Minor in AUTOMOBILE & AEROSPACE	Minor in Industry 4.0	L-T-P	Credit
1st	Basic Electrical and Eletronics Engg	Basic Electrical and Eletronics Engg	Basic Electrical and Eletronics Engg	3-0-3	4.5
3rd	Mathematics III	Mathematics III	Mathematics III	3-0-0	3
	Computer fundamentals and Programming	Computer fundamentals and Programming	Computer fundamentals and Programming	3-0-0	3
4th	Data structure, Microprocessor in Automation	Data structure, Gas Dynamics and Jet Propulsion	Data structure, Internet of Things	5-0-0	5
5th	Mechatronics Systems	Fluid Power control	Data Base Management System	3-1-1	5
6th	3D Printing and Design	Electrical Machines	Artificial Intelligence and Machine Learning	3-1-1	5
7th	Robotics	Electric Vehicles	Cyber Security and Blockchain	3-1-0	4
8th	Industrial Instrumentation	Energy Conservation and Management	Data Science and Industry 4.0	3-0-0	3
TOTAL					32.5

First Year First Semester

Sl. No.	Category	Course Code	Course Title	Hours per week				Credits
				L	T	P	Total	
C. THEORY								
1	Major	ME101	Engineering Mechanics	3	0	0	3	3
	Minor	EE(ME)101	Basic Electrical and Electronics Engineering.	3	0	0	3	3
2	Multidisciplinary	PH(ME)101	Engineering Physics	3	0	0	3	3
3	Multidisciplinary	M(ME)101	Engineering Mathematics –I	3	0	0	3	3
4	VAC	HU104	Environmental science	2	0	0	2	2
5	VAC	HU105	Indian Knowledge System	1	0	0	1	1
D. PRACTICAL								
1	Major	ME191	Engineering Graphics and Design Lab	0	0	3	3	1.5
2	Minor	EE(ME)191	Basic Electrical and Electronics Engineering Lab	0	0	3	3	1.5
3	Ability Enhancement Course	HU(ME)192	Design Thinking and Prototyping	0	0	2	2	1
4	Skill Enhancement Course	PH(ME)191	Engineering Physics Lab	0	0	3	3	1.5
5	Skill Enhancement Course	HU(ME)191	Technical Report Writing & Language Lab	0	0	3	3	1.5
TOTAL CREDIT								22

*‘Mandatory Additional Requirement’(MAR) activities have to be carried out as per university guidelines

COURSE NAME: ENGINEERING MECHANICS**COURSE CODE: ME101**

CONTACTS: 3:0:0

TOTAL CONTACT HOURS: 36**CREDITS: 3****Prerequisites:** Basic Concept of Physics

Course Outcomes:

CO1: Understand representation of force, moments for drawing free-body diagrams and analyze friction-based systems in static condition.

CO2: Calculate the centroid of an area and calculate the moment of inertia of a section.

CO3: Apply of conservation of momentum & energy principle for particle dynamics and rigid body kinetics.

CO4: Understand and apply the concept of virtual work, rigid body dynamics and systems under vibration.

Course Contents:

Module No.	Syllabus	Contact Hrs.
Module 1: Introduction to Engineering Mechanics:	Force Systems Basic concepts, Particle equilibrium in 2-D & 3-D; Rigid Body equilibrium; System of Forces, Coplanar Concurrent Forces, Components in Space – Resultant- Moment of Forces and its Application; Couples and Resultant of Force System, Equilibrium of System of Forces, Free body diagrams, Equations of Equilibrium of Coplanar Systems and Spatial Systems; Vector Mechanics- dot product, cross product, Problems.	8
Module 2: Friction:	Types of friction, Limiting friction, Laws of Friction, Static and Dynamic Friction; Motion of Bodies, wedge friction, screw jack & differential screw jack, Problems.	4
Module 3: Basic Structural Analysis:	Equilibrium in three dimensions; Method of Sections; Method of Joints; How to determine if a member is in tension or compression; Simple Trusses; Zero force members; Beams & types of beams; Frames & Machines, Problems.	4
Module 4: Centroid and Centre of Gravity:	Distributed Force: Centroid and Centre of Gravity; Centroids of a triangle, circular sector, quadrilateral, etc., Centroid of simple figures from first principle, centroid of composite sections; Centre of Gravity and its implications, Problems.	4
Module 5: Moment of Inertia:	Area moment of inertia- Definition, Moment of inertia of plane sections from first principles, Theorems of moment of inertia, Moment of inertia of standard sections and composite sections; Mass moment inertia of circular plate, Cylinder, Cone, Sphere, Hook, Problems.	4

Module 6: Virtual Work and Energy Method:	Virtual displacements, principle of virtual work for particle and ideal system of rigid bodies, degrees of freedom. Active force diagram, systems with friction, mechanical efficiency. Conservative forces and potential energy (elastic and gravitational), energy equation for equilibrium. Applications of energy method for equilibrium. Stability of equilibrium, Problems.	3
Module 7: Review of particle dynamics:	Rectilinear motion; Plane curvilinear motion (rectangular, path, and polar coordinates). 3-D curvilinear motion; Relative and constrained motion; Newton's 2 nd law (rectangular, path, and polar coordinates). Work-kinetic energy, power, potential energy. Impulse-momentum (linear, angular); Impact (Direct and oblique), Problems	5
Module 8: Introduction to Kinetics of Rigid Bodies:	Basic terms, general principles in dynamics; Types of motion, Instantaneous centre of rotation in plane motion and simple problems; D'Alembert's principle and its applications in plane motion and connected bodies; Work energy principle and its application in plane motion of connected bodies; Kinetics of rigid body rotation, Problems.	4

Text books:

1. Irving H. Shames (2006), Engineering Mechanics, 4th Edition, Prentice Hall
2. F. P. Beer and E. R. Johnston (2011), Vector Mechanics for Engineers, Vol I - Statics, Vol II, -Dynamics, 9th Ed, Tata McGraw Hill
3. R.C. Hibbler (2006), Engineering Mechanics: Principles of Statics and Dynamics, Pearson Press.
4. Andy Ruina and Rudra Pratap (2011), Introduction to Statics and Dynamics, Oxford University Press
5. Shames and Rao (2006), Engineering Mechanics, Pearson Education,
6. Hibler and Gupta (2010), Engineering Mechanics (Statics, Dynamics) by Pearson Education

Reference books:

1. Reddy Vijaykumar K. and K. Suresh Kumar (2010), Singer's Engineering Mechanics
2. Bansal R.K. (2010), A Text Book of Engineering Mechanics, Laxmi Publications
3. Khurmi R.S. (2010), Engineering Mechanics, S. Chand & Co.
4. Tayal A.K. (2010), Engineering Mechanics, Umesh Publications

CO – PO/PSO Mapping:

COS	PO 1	PO 2	PO3	PO 4	PO 5	PO6	PO7	PO 8	PO 9	PO 10	PO 11	PO 12	PSO1	PSO2	PSO3
CO 1	3	3	2	2	-	-	-	-	-	-	-	-	1	-	-
CO 2	3	3	2	2	-	-	-	-	-	-	-	-	2	1	-
CO 3	3	2	3	2	-	-	-	-	-	-	-	-	2	1	-
CO 4	3	3	3	3	-	-	-	-	-	-	-	-	1	2	-
Avg	3	2.7 5	2.5	1.7 5	-	-	-	-	-	-	-	-	1.5	1	-

COURSE NAME: BASICS ELECTRICAL AND ELECTRONICS ENGINEERING

COURSE CODE: EE(ME)101

CONTACT: 3:0:0

TOTAL CONTACT HOURS: 36

CREDITS: 3

Pre requisite: Knowledge of Physics up to 12th standard.

Course Outcomes (COs):

COs	Statement
CO1	Apply fundamental concepts and circuit laws to solve simple DC electric circuits
CO2	To solve simple ac circuits in steady state
CO3	Impart the knowledge of Basic Electronics Devices and ICs.
CO4	Analyze the simple electronics circuits

Course Content:

MODULE 1: Elementary Concepts of Electric Circuits 6L

DC Circuits: Circuit Components: Conductor, Resistor, Inductor, Capacitor – Ohm's Law - Kirchhoff's Laws –Independent and Dependent Sources – Simple problems- Nodal Analysis, Mesh analysis with independent sources only (Steady state)

Introduction to AC Circuits and Parameters: Waveforms, Average value, RMS Value, Instantaneous power, real power, reactive power and apparent power, power factor – Steady state analysis of RLC circuits (Simple problems only)

MODULE 2: Electrical machine 8L

Transformer: Magnetic materials, BH characteristics, ideal and practical transformer, equivalent circuit, losses in transformers, regulation and efficiency.

DC Machines: Brief idea on constructional features, classifications, working principle of both motor and generator. Simple problems on Voltage equation.

MODULE 3: Fundamentals of Semiconductor Devices: 6L

Introduction to Semiconductor: Concept of energy band diagram; Comparison among metal, insulator, semiconductor; Semiconductors-classifications and Fermi energy level; Charge neutrality and Mass-Action law in semiconductor; Current flow in semiconductor due to drift & diffusion process; Einstein relation.

MODULE 4: PN Junction Diode: 4L

Principle of operation; V-I characteristics; principle of avalanche & Zener

CO4	3	2	2	2	--	--	--	--	--	--	--	1
CO5	3	3	3	2	2	--	--	--	--	--	--	1

Course Content:

Module 1 (12L)

Modern Optics

1.01- Laser: Concepts of various emission and absorption processes, Einstein A and B coefficients and

equations, working principle of laser, metastable state, population inversion, condition necessary for active laser action, optical resonator, illustrations of Ruby laser, He-Ne laser, Semiconductor laser, applications of laser, related numerical problems.

6L **1.02-Fibre optics-**

Principle and propagation of light in optical fibers (Step index, Graded index, single and multiple modes) - Numerical aperture and Acceptance angle, Basic concept of losses in optical fiber, related numerical problems.

3L

1.03-Holography-Theory of holography, viewing of holography, applications

3L

Module 2 (6L)

Solid State Physics

2.01 Crystal Structure: Structure of solids, amorphous and crystalline solids (definition and examples), lattice, basis, unit cell, Fundamental types of lattices –Bravais lattice, simple cubic, fcc and bcc lattices, Miller indices and miller planes, co-ordination number and atomic packing factor, Bragg’s equation, applications, numerical problems.

3L

2.02 Semiconductor: Physics of semiconductors, electrons and holes, metal, insulator and semiconductor, intrinsic and extrinsic semiconductor, p-n junction.

3L

Module 3 (8L)

Quantum Mechanics

3.01 Quantum Theory: Inadequacy of classical physics-concept of quantization of energy, particle concept of electromagnetic wave (example: photoelectric and Compton Effect; no

derivation required, origin of modified and unmodified lines), wave particle duality; phase velocity and group velocity; de Broglie hypothesis; Davisson and Germer experiment, related numerical problems. 4L

3.02 Quantum Mechanics 1: Concept of wave function, physical significance of wave function, probability interpretation; normalization of wave functions-Qualitative discussion; uncertainty principle, relevant numerical problems, Introduction of Schrödinger wave equation (only statement).

4L

Module 4 (4L)

Physics of Nanomaterials

Reduction of dimensionality, properties of nanomaterials, Quantum wells (two dimensional), Quantum wires (one dimensional), Quantum dots (zero dimensional); Quantum size effect and Quantum confinement. Carbon allotropes. Application of nanomaterials (CNT, graphene, electronic, environment, medical).

Module 5 (6L)

Ultrasound and Infrasonnd

Ultrasound-Introduction, definition and properties –Production of ultrasonics by Piezo-electric crystal and magnetostriction method; Detection of ultrasonics; Engineering applications of Ultrasonics (Non-destructive testing, cavitations, measurement of gauge), Infrasonnd – Introduction and definition, production, application.

Text Books:

1. Refresher courses in physics (Vol. 1, Vol. 2 & Vol. 3)-C. L. Arora (S. Chand Publishers)
2. Engineering Physics (Vol. 1, Vol. 2)-S.P. Kuila (S. Chand Publishers).
3. Perspective & Concept of Modern Physics -Arthur Baiser (Publisher: MaGrawhill)
4. Principles of engineering physics – Md. N Khan and S Panigrahi (Cambridge University Press).
5. Concepts of Modern Engineering Physics-A. S. Vasudeva. (S. Chand Publishers)
6. Engineering Physics (Vol. 1, Vol. 2)-S.P. Kuila (S. Chand Publishers).
7. Physics Volume 1&2 - Haliday, Resnick & Krane, Publisher: Wiley India).
8. Engineering Physics-B. K. Pandey And S. Chaturvedi (Publisher: Cengage Learning, New Delhi).

Recommended Reference Books for Physics I:

Modern Optics:

1. A text book of Light-Brijlal & Subhramanium, (S. Chand publishers).
2. Optics-Ajay Ghatak (TMH)

Solid State Physics:

1. Solid state physics- S. O. Pillai.
2. Introduction to solid state physics-Kittel (TMH).

Quantum Mechanics:

1. Introduction to Quantum Mechanics-S. N. Ghoshal (Calcutta Book House).
2. Quantum mechanics -A.K. Ghatak and S Lokenathan

Physics of Nanomaterials

1. Introduction to Nanotechnology, B.K. Parthasarathy.
2. Introduction to Nanoscience and Nanotechnology, An Indian Adaptation-Charles P. Poole, Jr., Frank J. Owens.

Ultrasound and Infrasonud

1. Principles of Accoustics-B. Ghosh (Sreedhar Publishers)
2. A Treatise on Oscillations, Waves and Acoustics-D. Chattopadhyay.

Course Content:**Module I: Linear Algebra (11L)**

Echelon form and normal (canonical) form of a matrix; Inverse and rank of a matrix; Consistency and inconsistency of system of linear equations, Solution of system of linear equations; Eigenvalues and eigenvectors; Diagonalization of matrix, Cayley-Hamilton theorem.

Module II: Single Variable Calculus (5L)

Rolle's Theorem, Mean value theorems, Taylor's and Maclaurin theorems with remainders; Concept of sequence and series, Power series; Taylor's series.

Module III: Multivariable Calculus (Differentiation) (13L)

Function of several variables; Concept of limit, continuity and differentiability; Partial derivatives, Total derivative and its application; chain rules, Derivatives of implicit functions Euler's theorem on homogeneous function; Jacobian; Maxima and minima of functions of two variables.

Module IV: Multivariable Calculus (Integration) (7L)

Double Integral, Triple Integral; Change of order in multiple integrals; Line Integral, Surface Integral, Volume Integral. Change of variables in multiple integrals.

Text Books:

1. Grewal, B.S., Higher Engineering Mathematics, Khanna Publishers, 36th Edition, 2010.
2. Kreyszig, E., Advanced Engineering Mathematics, 9th Edition, John Wiley & Sons, 2006.

Reference Books:

1. Guruprasad, S. A text book of Engineering Mathematics-I, New age International Publishers.
2. Ramana, B.V., Higher Engineering Mathematics, Tata McGraw Hill New Delhi, 11th Reprint, 2010.
3. Veerarajan, T., Engineering Mathematics for first year, Tata McGraw-Hill, New Delhi, 2008.
4. Bali, N.P. and Goyal, M., A text book of Engineering Mathematics, Laxmi Publications, Reprint, 2008.
5. Thomas, G.B. and Finney, R.L., Calculus and Analytic geometry, 9th Edition, Pearson, Reprint, 2002.
6. Apostol, M., Calculus, Volumes 1 and 2 (2nd Edition), Wiley Eastern, 1980.
7. Kumaresan, S., Linear Algebra - A Geometric approach, Prentice Hall of India, 2000.
8. Poole, D., Linear Algebra: A Modern Introduction, 2nd Edition, Brooks/Cole, 2005.
9. Bronson, R., Schaum's Outline of Matrix Operations. 1988.
10. Piskunov, N., Differential and Integral Calculus, Vol. I & Vol. II, Mir Publishers, 1969.

COURSE NAME: ENVIRONMENTAL SCIENCE

COURSE CODE: HU104

CONTACT (L: T: P): 2: 0: 0

TOTAL CONTACT HOURS: 24

CREDIT: 2

Prerequisites: 10+2

Course Objective(s)

This course will enable the students to,

- Realize the importance of environment and its resources.
- Apply the fundamental knowledge of science and engineering to assess environmental and health risk.
- Know about environmental laws and regulations to develop guidelines and procedures for health and safety issues.
- Solve scientific problem-solving related to air, water, land and noise pollution.

Course Outcome

CO	Statement
C01	Able to understand the natural environment and its relationships with human activities
C02	The ability to apply the fundamental knowledge of science and engineering to assess environmental and health risk
C03	Ability to understand environmental laws and regulations to develop guidelines and procedures for health and safety issues
C04	Acquire skills for scientific problem-solving related to air, water, noise & land pollution.

CO – PO Mapping

COs	PO1	PO 2	PO 3	PO 4	PO5	PO6	PO7	PO8	PO9	PO10	PO11	PO12
C01	2	2	3	-	-	2	3	3	-	-	1	2
C02	3	3	3	1	1	2	3	3	-	-	1	2

CO3	3	3	3	2	1	2	3	3	-	-	1	2
CO4	1	1	1	1	2	2	3	3	-	-	1	2
Avg	2	2	2	1	1	2	3	3	-	-	1	2

Module 1 - Resources and Ecosystem (6L)

1. Resources (2L)

Types of resources, resistance to resources, Human resource, Population Growth models: Exponential Growth, logistic growth

2. Ecosystem (3L)

Components of ecosystem, types of ecosystem, Forest ecosystem, Grassland ecosystem, Desert ecosystem, Aquatic ecosystems, Food chain, Food web.

3. Energy and Environment(1L)

Conventional energy sources, coal and petroleum, Green energy sources, solar energy, tidal energy, geothermal energy, biomass

Module 2 – Environmental Degradation (9L)

1. Air Pollution and its impact on Environment (3L)

Air Pollutants, primary & secondary pollutants, Criteria pollutants, Smog, Photochemical smog and London smog, Greenhouse effect, Global Warming, Acid rain, Ozone Layer Depletion.

2. Water Pollution and its impact on Environment (3L)

Water Pollutants, Oxygen demanding wastes, heavy metals, BOD, COD, Eutrophication, Hardness, Alkalinity, TDS and Chloride, Heavy metal poisoning and toxicity.

3. Land Pollution and its impact on Environment (2L)

Solid wastes, types of Solid Waste, Municipal Solid wastes, hazardous wastes, bio-medical wastes, E-wastes

4. Noise Pollution and its impact on Environment (1L)

Types of noise, Noise frequency, Noise pressure, Noise intensity, Noise Threshold limit, Effect of noise pollution on human health.

Module 3 – Environmental Management (6L)

1. Environmental Impact Assessment (1L)

Objectives of Environmental management, Components of Environmental Management, Environmental Auditing, Environmental laws and Protection Acts of India

2. Pollution Control and Treatment (2L)

Air Pollution controlling devices, Catalytic Converter, Electrostatic Precipitator, etc., Waste Water Treatment, Noise pollution control.

3. Waste Management (3L)

Solid waste management, Open dumping, Land filling, incineration, composting, E-waste management, Biomedical Waste management.

Module 4 – Disaster Management (3L)

1. Study of some important disasters (2L)

Natural and Man-made disasters, earthquakes, floods drought, landside, cyclones, volcanic eruptions, tsunami, Global climate change. Terrorism, gas and radiations leaks, toxic waste disposal, oil spills, forest fires.

2. Disaster management Techniques (1L)

Basic principles of disasters management, Disaster Management cycle, Disaster management policy, Awareness generation program

Text Books:

1. Basic Environmental Engineering and Elementary Biology (For MAKAUT),

Gourkrishna Dasmohapatra, Vikas Publishing.

2. Basic Environmental Engineering and Elementary Biology, Dr. Monindra Nath Patra & Rahul Kumar Singha, Aryan Publishing House.

3. Textbook of Environmental Studies for Undergraduate Courses, Erach Barucha for UGC, Universities Press

Reference Books:

1. A Text Book of Environmental Studies, Dr. D.K. Asthana & Dr. Meera Asthana, S.Chand Publications.
2. Environmental Science (As per NEP 2020), Subrat Roy, Khanna Publisher

COURSE NAME: INDIAN KNOWLEDGE SYSTEM

COURSE CODE: HU105

CONTACT (L: T: P): 1: 0: 0

TOTAL CONTACT HOURS: 12

CREDIT: 1

Prerequisite: Nil

CO1: To recall & state thought process of social setting in ancient India to identify the roots and details of some contemporary issues faced by Indians

CO 2: The students are able to identify & inspect the importance of our surroundings & culture to design & formulate sustainable developmental solutions

CO 3: To develop the ability to understanding the issues related to 'Indian' culture, tradition and its composite character to apply the same in the socio-technological developments in present scenario

CO 4: The students are able to relate & assess Indian Knowledge System in the health care, architecture, agriculture & other systems .

Module-1

3L

An overview of Indian Knowledge System (IKS): Importance of Ancient Knowledge - Definition of IKS - Classification framework of IKS - Unique aspects of IKS. The Vedic corpus: Vedas and Vedangas - Distinctive features of Vedic life. Indian philosophical systems: Different schools of philosophy.

Module-2

3L

Salient features of the Indian numeral system: Importance of decimal representation - The discovery of zero and its importance - Unique approaches to represent numbers.

Highlights of Indian Astronomy: Historical development of astronomy in India

Module-3

3L

Indian science and technology heritage : Metals and metalworking - Mining and ore extraction –Physical structures in India - Irrigation and water management - Dyes and painting technology - Surgical Techniques - Shipbuilding

Module-4**3L**

Traditional Knowledge in Different Sectors: Traditional knowledge and engineering, Traditional medicine system, Traditional Knowledge in agriculture, Traditional societies depend on it for their food and healthcare needs.

Text Book:

- 1) Introduction to Indian knowledge system: concepts and applications-[Mahadevan B.Bhat](#),
[Vinayak Rajat](#), [Nagendra Pavana R.N.](#), PHI

Reference Books:

- 1) Traditional Knowledge system in India, Amit Jha, Atlantic Publishers
2) S. N. Sen and K. S. Shukla, *History of Astronomy in India*, Indian National Science Academy, 2nd edition, New Delhi, 2000

CO and PO mapping:

CO \ PO	PO1	PO2	PO3	PO4	PO5	PO6	PO7	PO8	PO9	P10	P11	P12
CO1	-	-	2	3	-	3	-	2	3	1	-	2
CO2	-	-	2	-	-	3	3	2	3	3	-	
CO3	-	-	2	-	-	3	3	1	3	1	-	2
CO4			2			3	3	2	3			

COURSE NAME: ENGINEERING GRAPHICS & DESIGN LAB

COURSE CODE: ME191

CONTACT: 0:0:3

CREDITS: 1.5

Prerequisites: Basic knowledge of geometry

Course Outcomes: Upon successful completion of this course, the student will be able to:

CO1: Learn the basics of drafting.

CO2: Understand the use of drafting tools which develops the fundamental skills of industrial drawings.

CO3: Apply the concept of engineering scales, dimensioning and various geometric curves necessary to understand design of machine elements.

CO4: Analyze the concept of projection of line, surface and solids to create the knowledge base of orthographic and isometric view of structures and machine parts.

CO5: Evaluate the design model to different sections of industries as well as for research & development.

Course Contents:

Basic Engineering Graphics:

3P

Principles of Engineering Graphics; Orthographic Projection; Descriptive Geometry; Drawing Principles; Isometric Projection; Surface Development; Perspective; Reading a Drawing; Sectional Views; Dimensioning & Tolerances; True Length, Angle; intersection, Shortest Distance.

Module 1: Introduction to Engineering Drawing

6P

Principles of Engineering Graphics and their significance, Usage of Drawing instruments, lettering, Conic sections including Rectangular Hyperbola (General method only); Cycloid, Epicycloid and Involute; Scales – Plain, Diagonal and Vernier Scales.

Module 2: Orthographic & Isometric Projections

6P

Principles of Orthographic Projections-Conventions - Projections of Points and lines inclined to both planes; Projections of planes on inclined Planes - Auxiliary Planes; Projection of Solids inclined to both the Planes- Auxiliary Views; Isometric Scale, Isometric Views of lines, Planes, Simple and compound Solids; Conversion of Isometric Views to Orthographic Views and Vice-versa.

Module 3: Sections and Sectional Views of Right Angular Solids

6P

Drawing sectional views of solids for Prism, Cylinder, Pyramid, Cone and project the true shape of the sectioned surface, Auxiliary Views; Development of surfaces of Right Regular Solids - Prism, Pyramid, Cylinder and Cone; Draw sectional orthographic views of objects from industry and dwellings (foundation to slab only).

Computer Graphics:**3P**

Engineering Graphics Software; -Spatial Transformations; Orthographic Projections; Model Viewing; Co-ordinate Systems; Multi-view Projection; Exploded Assembly; Model Viewing; Animation; Spatial Manipulation; Surface Modeling; Solid Modeling.

Module 4: Overview of Computer Graphics**3P**

Demonstration of CAD software [The Menu System, Toolbars (Standard, Properties, Draw, Modify and Dimension), Drawing Area (Background, Crosshairs, Coordinate System), Dialog boxes and windows, Shortcut menus (Button Bars), Zooming methods, Select and erase objects].

Module 5: CAD Drawing, Customization, Annotations, layering**6P**

Set up of drawing page including scale settings, ISO and ANSI standards for dimensioning and tolerance; Using various methods to draw straight lines, circles, applying dimensions and annotations to drawings; Setting up and use of Layers, changing line lengths (extend/lengthen); Drawing sectional views of solids; Drawing annotation, CAD modeling of parts and assemblies with animation, Parametric and nonparametric solid, surface and wireframe modeling, Part editing and printing documents.

Module 6: Demonstration of a simple team design project**3P**

Illustrating Geometry and topology of engineered components: creation of engineering models and their presentation in standard 2D blueprint form and as 3D wire-frame and shaded solids; Meshed topologies for engineering analysis and tool-path generation for component manufacture, use of solid-modeling software for creating associative models at the component and assembly levels.

Text Books:

1. Bhatt N.D., Panchal V.M. & Ingle P.R, (2014), Engineering Drawing, Charotar Publishing House
2. K. Venugopal, Engineering Drawing + AutoCAD, New Age International publishers

Reference Books:

1. Pradeep Jain, Ankita Maheswari, A.P. Gautam, Engineering Graphics & Design, Khanna Publishing House
2. Agrawal B. & Agrawal C. M. (2012), Engineering Graphics, TMH Publication.
3. Shah, M.B. & Rana B.C. (2008), Engineering Drawing and Computer Graphics, Pearson Education
4. Narayana, K.L. & P Kanniah (2008), Text book on Engineering Drawing, Scitech Publishers.

CO-PO/PSO Mapping:

COs	PO 1	PO 2	PO 3	PO 4	PO 5	PO 6	PO 7	PO 8	PO 9	PO 10	PO 11	PO 12	PSO 1	PSO 2	PSO 3
CO1	2			2									2	2	2
CO2	2			2									2	2	2
CO3	3			2									2	2	2
CO4	3			3									3	3	2
CO5	3	2		3	2								3	3	2

**COURSE NAME: BASIC ELECTRICAL AND ELECTRONICS ENGINEERING
LABORATORY**

COURSE CODE: EE(ME)191

CONTACT: 0:0:3

CREDITS: 1.5

Course Outcomes:

COs	Statement
CO1	To analyze a given network by applying KVL and KCL.
CO2	To examine the Operation of DC Motor.
CO3	To examine the Operation of Basic Electronics Devices and ICs.
CO4	To design simple electronics circuits.

Course Contents:

List of Experiments: -

1. Familiarization with different passive and active electrical & electronic components.
2. Familiarization with different Electrical & Electronics Instruments.
3. Verification of KVL and KCL.
4. Forward and reversal of DC shunt motor.
5. Speed control of DC shunt motor.
6. Study of the P-N junction diode V-I characteristics (Forward & Reverse Bias).
7. Study of the Characteristics of Zener diode (Forward & Reverse Bias).
8. Study of the Input and Output characteristics of BJT in CE mode.
9. Determination of offset voltage, offset current & bias current of OPAMP(IC741).
10. Determination of CMRR and slew rate of OPAMP(IC741).
11. Determination of inverting and non-inverting gain of OPAMP(IC741).
12. Extramural Experiment.

Textbooks:

1. Handbook of Laboratory Experiments in Electronics Engineering Vol. 1, Author Name: A.M. Zungeru, J.M. Chuma, H.U. Ezea, and M. Mangwala, Publisher -Notion Press
Electronic Devices and Circuit Theory by Robert Boylestad Louis Nashelsky, 7th Edition, Prentice Hall

2. Experiments Manual for use with Grob's Basic Electronics 12th Edition by Wes Ponick, Publisher-McGraw Hill,2015
3. Laboratory Manual for 'Fundamentals of Electrical & Electronics Engineering': A handbook for Electrical & Electronics Engineering Students by Manoj Patil (Author), Jyoti Kharade (Author), 2020
4. The Art of Electronics, Paul Horowitz, Winfield Hill, Cambridge University Press, 2015.
5. A Handbook of Circuit Math for Technical Engineers, Robert L. Libbey
CRC Press, 05-Jun-1991

Reference Books

1. Basic Electrical and Electronics Engineering, Author:S. K. Bhattacharya,
Publisher: Pearson Education India,2011
2. Practical Electrical Engineering
3. By Sergey N. Makarov, Reinhold Ludwig, Stephen J. Bitar, Publisher: Springer International Publishing, 2016
4. Electronics Lab Manual (Volume 2) By Navas, K. A. Publisher: PHI Learning Pvt. Ltd. 2018
5. Practical Electronics Handbook, Ian R. Sinclair and John Dunton, Sixth edition 2007, Published by Elsevier Ltd.

CO-PO Course Articulation Matrix Mapping:

COs	PO1	PO2	PO3	PO4	PO5	PO6	PO 7	PO8	PO9	PO 10	PO 11	PO 12
CO1	3	2	3	2	-	2	-	-	2	-	2	3
CO2	3	3	2	3	-	2	-	-	3	-	2	2
CO3	3	2	2	3	-	2	-	-	2	-	3	3
CO4	3	3	2	2	-	2	-	-	3	-	2	3

COURSE NAME: DESIGN THINKING & PROTOTYPING

COURSE CODE: HU(ME)192

CONTACT: 0:0:2

CREDITS: 1

Course Contents:

Module 1: Understanding the Learning Process, Kolb's Learning Styles, Assessing and Interpreting. **2L**

Module 2: Memory: process, Sensory memory, STM and LTM, Problems in retention, Memory enhancement techniques. **4L**

Module 3: Emotions: Experience & Expression Understanding Emotions, Empathy, And Concept of Emotional Intelligence. **2L**

Module 4: Basics of Design Thinking Definition of Design Thinking, Need for Design Thinking, Objective of Design Thinking, Concepts & Brainstorming, Stages of Design Thinking Process (explain with examples) – Empathize, Define, Ideate, Prototype, Test. **6L**

Module 5: Understanding Creative thinking process, Understanding Problem Solving, Testing Creative Problem Solving **4L**

Unit 6: Prototyping & Testing -Rapid Prototype Development process, Testing, Sample Example, Test Group Marketing **2L**

Module-7: Design thinking for strategic innovations Growth –Change- Examples of Customer Challenges, Use of Design Thinking to Enhance Customer Experience -Value redefinition - Extreme Competition –Standardization —Strategy– Business Model design. **4L**

References:

1. John.R.Karsnitz, Stephen O'Brien and John P. Hutchinson, "Engineering Design", Cengage learning (International edition) second Edition, 2013.
2. Roger Martin, "The Design of Business: Why Design Thinking is the Next Competitive Advantage", Harvard Business Press, 2009.
3. Idris Mootee, "Design Thinking for Strategic Innovation: What They Can't Teach You at Business or Design School", John Wiley & Sons 2013
4. George, E, Dieter, Linda, C, Schmidt. (2017). Engineering Design, McGraw Hill publisher, 4th edition.

COURSE NAME: ENGINEERING PHYSICS LAB**CODE: PH(ME)191****CONTACT HOURS: 0:0:3****CREDIT: 1.5****Prerequisites:** Knowledge of Physics up to 12th standard.**Course Objectives:**

The aim of course is to provide adequate exposure and develop insight about the basic principles of physical sciences and its practical aspects which would help engineers to learn underlying principles of various tools and techniques they use in core engineering and related industrial applications. The course would also inculcate innovative mindsets of the students and can create awareness of the vital role played by science and engineering in the development of new technologies.

Course Outcomes (COs):

After attending the course students' will be able to

CO1: demonstrate experiments allied to their theoretical concepts

CO2: conduct experiments using LASER, Optical fiber.

CO3: participate as an individual, and as a member or leader in groups in laboratory sessions actively

CO4: analyze experimental data from graphical representations, and to communicate effectively them in Laboratory reports including innovative experiment.

CO5: Design solutions for real life challenges.

CO-PO Mapping:

COs	PO1	PO2	PO3	PO4	PO5	PO6	PO7	PO8	PO9	PO10	PO11	PO12
CO1	2	3	2	3	3	--	--	--	--	--	--	--
CO2	2	3	2	3	3	--	--	--	--	--	--	--
CO3	2	3	2	3	3	--	--	--	--	--	--	--
CO4	2	2	3	2	3	--	--	--	--	--	--	--
CO5	2	2	3	2	3	--	--	--	--	--	--	--

Course Content:

General idea about Measurements and Errors (One Mandatory):

i) Error estimation using Slide calipers/ Screw-gauge/travelling microscope for one experiment.

Experiments on Classical Physics (Any 4 to be performed from the following experiments):

1. Study of Torsional oscillation of Torsional pendulum & determination of time using various load of the oscillator.
2. Determination of Young's moduli of different materials.
3. Determination of Rigidity moduli of different materials.
4. Determination of wavelength of light by Newton's ring method.
5. Determination of wavelength of light by Laser diffraction method.
6. Optical Fibre-numerical aperture, power loss.

Experiments on Quantum Physics (Any 2 to be performed from the following experiments):

7. Determination of Planck's constant using photoelectric cell.
8. Verification of Bohr's atomic orbital theory through Frank-Hertz experiment.
9. Determination of Stefan's Constant.
10. Study of characteristics of solar cell.

Perform atleast one of the following experiments:

11. Determination of dielectric constant of given sample (frequency dependent)
12. Determination of velocity of ultrasonic wave using piezoelectric crystal.

**In addition it is recommended that each student should carry out at least one experiment beyond the syllabus/one experiment as Innovative experiment.

Probable experiments beyond the syllabus:

1. Study of dispersive power of material of a prism.
2. Study of viscosity using Poiseuille's capillary flow method/using Stoke's law.
3. Determination of thermal conductivity of a bad/good conductor using Lees-Charlton / Searle apparatus.
4. Determination of the angle of optical rotation of a polar solution using polarimeter.
5. Any other experiment related to the theory.

Recommended Text Books for Engineering Physics Lab:

Waves & Oscillations:

1. Vibration, Waves and Acoustics- Chattopadhyay and Rakshit Classical & Modern

Optics:

2. A text book of Light- K.G. Mazumder & B.Ghosh (Book & Allied Publisher)

Quantum Mechanics-I

1. Introduction to Quantum Mechanics-S. N. Ghoshal (Calcutta Book House)

Solid State Physics:

1. Solid State Physics and Electronics-A. B. Gupta and Nurul Islam (Book & Allied Publisher)

Text Books:

1. Practical Physics by Chatterjee & Rakshit (Book & Allied Publisher)

2. Practical Physics by K.G. Mazumder (New Central Publishing)

3. Practical Physics by R. K. Kar (Book & Allied Publisher)

COURSE NAME: TECHNICAL REPORT WRITING AND LANGUAGE LAB

CODE: HU(ME)191

CONTACT HOURS: 0:0:3

CREDIT: 1.5

Pre requisites: A basic knowledge of listening and speaking skills and the ability to infer meaning from audio-video/online lessons and Communication Competence

Course Objective: To maximize exposure and train students in the professional use of English in the globalized workplace.

Course Outcome:

CO	Statement
CO1	Able to develop advanced verbal and nonverbal communication skills through Power Point presentation.
CO2	Able demonstrate interpersonal skills through Group Discussion both for organizational communication and campus recruitment drive.
CO3	Able to recognize and apply the knowledge of public speaking.
CO4	Able to be industry ready professionals by various personality development programs.
CO5	Understand and write a detailed technical report as per organizational needs

Course contents:

Module 1: Presentation [2L+6P]

- (a)Teaching Presentation as a Skill
- (b)Speaking Strategies and Skills
- (c)Media and Means of Presentation
- (d)Extended Practice and Feedback

Module 2: Effective Presentation [2L+6P]

- a) Rules of making micro presentation.
- b) Assignment on micro presentation.
- c) Need for expertise in oral presentation.
- d) Assignment on Oral presentation.
- e) Macro Presentation in Groups.

Module 3: Writing a Technical Report [2L+6P]

- (a)Organizational Needs for Reports and types
- (b)Report Formats
- (c)Report Writing Practice Sessions and Workshops

Module 4: Speaking Skills [2L+6P]

- (a)The Need for Speaking: Content and Situation-based speaking
- (b)Public Speaking Activities: [Just a Minute, Paired Role Play, Situational Speaking Exercises]
- (c)The Pragmatics of Speaking—Pronunciation practice and learner feedback.

Text / Reference Books: Technical communication By Meeenakshi Raman and SangeetaSharma; Oxford Publication.

CO-PO mapping

CO	PO1	PO2	PO3	PO4	PO5	PO6	PO7	PO8	PO9	PO10	PO11	PO12
CO1	3	-	3	-	3	2	-	-	3	3	1	3
CO2	3	3	-	-	-	3	-	-	3	3	-	3
CO3	2	2	2	-	-	2	1	-	3	3	1	3
CO4	2	-	-	-	1	3	-	-	3	3	1	3
CO5	1	2	-	-	2	2	-	2	3	3	1	3

First Year 2nd Semester

Sl. No.	Category	Course Code	Course Title	Hours per week				Credits
				L	T	P	Total	
THEORY								
1	Major	ME201	Fluid Mechanics	3	0	0	3	3
2	Multidisciplinary	M(ME)201	Engineering Mathematics II	3	0	0	3	3
3	Multidisciplinary	CH(ME)201	Engineering Chemistry	2	0	0	2	2
4	Ability Enhancement Course	HU201	Professional Communication	2	0	0	2	2
5	VAC	HU202	Values & Ethics	2	0	0	2	2
6	VAC	HU203	Constitution of India	1	0	0	0	1
PRACTICAL								
1	Major	ME291	Workshop and Manufacturing Practices Lab	0	0	3	3	1.5
2	Ability Enhancement Course	HU291	Professional Communication Lab	0	0	2	2	1
3	Skill Enhancement Course	ME292	AutoCAD Lab	0	0	3	3	1.5
4	Skill Enhancement Course	CH(ME)291	Engineering Chemistry Lab	0	0	2	2	1
TOTAL CREDIT								18

*‘Mandatory Additional Requirement’(MAR) activities have to be carried out as per university guidelines.

COURSE NAME: FLUID MECHANICS

COURSE CODE: ME201

CONTACT: 3:0:0

TOTAL CONTACT HOURS: 36

CREDIT: 3

Prerequisite: Physics and Mechanics (10+2 level)

Course Outcomes:

CO1: Get knowledge about fluid flow properties and analyze hydrostatic forces on flat or curved surfaces.

CO2: Explore the detailed analysis of kinematics and dynamics of fluid for laminar and turbulent flow and exploit the conservation equations for the flow regimes of practical interest.

CO3: Learn about boundary layer theory for a variety of constraints and understand the basics of a turbulent flow.

CO4: Explain the basics of compressible flow and apply for dimensional analysis for practical prototyping.

Course Contents

Module No.	Syllabus	Contact Hrs.
1 Introduction	Introduction to Fluid Mechanics - Fluid, Fluid types, Newton's law of viscosity, surface tension	2
2 Analysis of Fluid Motion	Fluid statics: Forces on submerged surfaces; forces on vertical, horizontal, inclined and curved surfaces, Center of pressure. Stability of floating bodies. Fluid kinematics: fluid flow and classifications. Continuity equation in 1D & 3D. Potential flow & Stream function; types of flow lines. Dynamics of fluid: equations of motion; Euler's equation; Navier-Stokes equation; Bernoulli's equation; Applications of Bernoulli's equation.	9
3 Viscous and Turbulent Flow	Flow through circular pipes, Flow between parallel plates, momentum and energy correction factors, Reynold's experiment, characteristics of turbulent flow, velocity distribution in turbulent flow through pipes.	5
4 Flow through pipes	Fluid friction in pipes, head loss due to friction. Darcy-Weisbach equation of friction loss; hydraulic grade line and total energy line. Variation of friction factor with wall roughness – Moody's chart. Minor losses in pipes.	4

5 Flow Measurement	Orifices, notches and weirs: Basic principle for flow through orifices, rectangular and V-notches, rectangular and trapezoidal weir	3
6 Boundary layer flow	Definition; Boundary layer separation – basic concept. Drag force on a flat plate due to boundary layer, Turbulent layer on a flat plate, displacement thickness, momentum thickness	4
7 Submerged bodies	Flow of fluid and forces around submerged bodies; basic concepts of drag and lift.	3
8 Dimensional Analysis	Dimensions and dimensional homogeneity, Importance and use of dimensional analysis. Buckingham's π theorem with applications. Geometric, Kinematic and Dynamic similarity, Non-dimensional Numbers, Model studies	3
9 Compressible Flow	Thermodynamic relations, Basic equations of compressible flow, velocity of pressure wave in a fluid, Mach number, Stagnation properties, area velocity relationship, flow of compressible fluid through orifices and nozzles fitted to a large	3

Text Books:

1. Introduction to Fluid Mechanics & Fluid Machines – Som & Biswas, TMH
2. Fluid Mechanics & Machinery – R.K.Bansal, Luxmi Publications.
3. A textbook on Fluid Mechanics and Hydraulic Machines – Sukumar Pati, TMH
4. Fluid Mechanics & Turbo Machines – M.M.Das, PHI, 2010.

Reference Books:

1. Introduction to Fluid Mechanics – Fox & Macdonald, Wiley.
2. Fluid Mechanics – Fundamentals & Applications – Cengel & Cimbala, TMH.
3. Mechanics of Fluid – Bernard Massey, Taylor & Francis

CO – PO/PSO Mapping:

COs	PO1	PO2	PO3	PO4	PO5	PO6	PO7	PO8	PO9	PO10	PO11	PO12	PSO1	PSO2	PSO3
CO1	2	2	1	1	-	-	1	-	-	-	-	-	3	2	-
CO2	3	3	2	2	-	-	1	-	-	-	-	1	2	3	-
CO3	3	2	1	2	-	-	1	-	-	-	-	1	3	2	-
CO4	2	2	1	1	-	-	1	-	-	-	-	1	1	3	-
Avg	2.5	1.75	1.25	1.5	-	-	1	-	-	-	-	0.75	2.25	2.75	-

M(ME) 201	2.75	2.25	1.5	2	-	-	-	-	-	-	-	1.25
--------------	------	------	-----	---	---	---	---	---	---	---	---	------

Course Content:

Module I: First Order Ordinary Differential Equations (ODE) (9L)

Solution of first order and first degree ODE: Exact ODE, Rules for finding Integrating factors, Linear ODE, Bernoulli's equation.

Solution of first order and higher degree ODE: solvable for p , solvable for y and solvable for x and Clairaut's equation.

Module II: Second Order Ordinary Differential Equations (ODE) (8L)

Solution of second order ODE with constant coefficients: C.F. & P.I., Method of variation of parameters, Cauchy-Euler equations.

Module III: Laplace Transform (LT) (12L)

Concept of improper integrals; Definition and existence of LT, LT of elementary functions, First and second shifting properties, Change of scale property, LT of $tf(t)$, LT of $\frac{f(t)}{t}$, LT of derivatives of $f(t)$, LT of integral of $f(t)$, Evaluation of improper integrals using LT, LT of periodic and step functions, Inverse LT: Definition and its properties, Convolution theorem (statement only) and its application to the evaluation of inverse LT, Solution of linear ODE with constant coefficients (initial value problem) using LT.

Module IV: Numerical Methods (7L)

Introduction to error analysis, Calculus of finite difference. **Interpolation:** Newton forward and backward interpolation, Lagrange's interpolation. **Numerical integration:** Trapezoidal rule, Simpson's 1/3 rule. **Numerical solution of ordinary differential equation:** Euler method, Fourth order Runge-Kutta method.

Text Books:

1. Grewal, B.S., Higher Engineering Mathematics, Khanna Publishers, 36th Edition, 2010.
2. Kreyszig, E., Advanced Engineering Mathematics, 9th Edition, John Wiley & Sons, 2006.

Reference Books:

1. Guruprasad, S. A text book of Engineering Mathematics-I, New age International Publishers.
2. Ramana, B.V., Higher Engineering Mathematics, Tata McGraw Hill New Delhi, 11th Reprint, 2010.
3. Veerarajan, T., Engineering Mathematics for first year, Tata McGraw-Hill, New Delhi, 2008.
4. Bali, N.P. and Goyal, M., A text book of Engineering Mathematics, Laxmi Publications, Reprint, 2008.

5. Thomas, G.B. and Finney, R.L., Calculus and Analytic geometry, 9th Edition, Pearson, Reprint, 2002.
6. Apostol, M., Calculus, Volumes 1 and 2 (2nd Edition), Wiley Eastern, 1980.
7. Kumaresan, S., Linear Algebra - A Geometric approach, Prentice Hall of India, 2000.
8. Poole, D., Linear Algebra: A Modern Introduction, 2nd Edition, Brooks/Cole, 2005.
9. Bronson, R., Schaum's Outline of Matrix Operations. 1988.
10. Piskunov, N., Differential and Integral Calculus, Vol. I & Vol. II, Mir Publishers, 1969.

COURSE NAME: ENGINEERING CHEMISTRY

COURSE CODE: CH(ME)201

CONTACT (L: T: P): 2: 0: 0

TOTAL CONTACT HOURS: 24

CREDIT: 2

Prerequisites: 10+2

COURSE OBJECTIVE

- To understand the basic principles of elements, organic reactions, drug synthesis and technological aspects of modern chemistry
- To apply the knowledge of different engineering materials, advanced polymers, and nanomaterials to solve complex engineering problems
- To analyse and evaluate quality parameters of water and its treatment
- Apply the knowledge of free energy, energy storage device, semiconductors, fuels and corrosion to design environment friendly & sustainable devices
- Apply the knowledge of different instrumental techniques to analyse unknown engineering materials.

COURSE OUTCOME

CO1. Able to understand the basic principles of elements, organic reactions drug synthesis and computational chemistry

CO2. Able to apply the knowledge of different engineering materials, advanced polymers, and nanomaterials to solve complex engineering problems

CO3. Able to analyse and evaluate water quality parameters and its treatment

CO4. Able to the knowledge of free energy, energy storage device, fuels and corrosion to design environment friendly & sustainable devices

CO5. Able to apply the knowledge of different instrumental techniques to analyse unknown engineering materials

CO-PO MAPPING

CO	PO1	PO2	PO3	PO4	PO5	PO6	PO7	PO8	PO9	PO10	PO11	PO12
1	3	3	2	2	2	-	-	-	-	-	2	2
2	3	3	3	3	-	-	2	-	-	-	2	2
3	3	3	-	-	-	-	3	-	-	-	3	2
4	3	3	3	2	-	-	3	-	-	-	3	2
5	3	3	3	3	2	-	-	-	-	-	2	2

Module 1 - Elements and their properties (6L)

4. Elements and their properties (3L)

Bohr's theory for one electron system, Hydrogen spectrum, Quantum numbers, Atomic orbitals, Pauli's exclusion principle, Hund's rule, exchange energy, Aufbau principle, Electronic configuration and Magnetic properties.

5. Periodic Table for Engineers (3L)

Modern Periodic table, Periodic properties, study of advanced functional materials like Silicones, Silicates, Zeolite and alloys like steel, mischmetall, Neodymium alloy and their applications

Module 2 - Energy devices and Semiconductors (6L)

5. Use of free energy in chemical equilibria (3L)

Laws of Thermodynamics, Enthalpy, Entropy, Spontaneity, Electrochemical Cell, Dry Cell, Mercury Cell, Lead Storage batteries, Fuel Cells, Solar Cells, Nernst equation and applications, Electrochemical sensors

6. Crystals and Semiconductors (3L)

Crystals and their defects, Stoichiometric and Non-stoichiometric defects, Band theory and Doping, n-type and p-type semiconductors, Superconductors

Module 3 –Industrial Applications of Chemistry (8L)

4. Advanced Polymeric materials (3L)

Classification, Engineering Plastics, conducting polymers, bio polymers, polymer composites

5. Industrial corrosion (2L)

Classification, Effects of corrosion, Preventive measures

6. Analysis of Water Quality (1L)

Water quality parameters

7. Fuels and their applications (2L)

Classification of Fuels, Calorific Values, Solid fuels; coal qualifications, Liquid Fuels; Knocking, Cetane and Octane number, composition and uses of gaseous fuels; water gas, Bio Gas, CNG, LPG

Module 4 – Organic Reaction Products and their spectroscopic analysis (4L)

3. Organic Reactions (2L)

Substitution, Elimination and Addition reactions

4. Drug designing and synthesis (1L)

Paracetamol, Aspirin

5. Spectroscopic Analysis (1L)

UV – Visible Spectra, IR spectra

Suggested Text Books

- (i) Fundamentals of Engineering Chemistry, By Dr. Sudip Bandopadhyay & Dr. Nirmal Kumar Hazra
- (ii) A Text Book of Engineering Chemistry by Dr. Rajshree Khare
- (iii) Engineering Chemistry 1, Gourkrishna Dasmohapatra

Reference Books

- (i) Engineering Chemistry, 16th Edition, P.C. Jain & Dr. Monica Jain
- (ii) A Text Book of Engg. Chemistry, Shashi Chawla, Dhanpat Rai & Co.
- (iii) Fundamentals of Molecular Spectroscopy, by C. N. Banwell
- (iv) Engineering Chemistry (NPTEL Web-book), by B. L. Tembe, Kamaluddin and M. S.Krishnan

COURSE NAME: PROFESSIONAL COMMUNICATION

COURSE CODE: HU201

CONTACT (L: T: P): 2: 0: 0

TOTAL CONTACT HOURS: 24

CREDIT: 2

Pre-requisites:	Basic (10+2) level of knowledge of English grammar, vocabulary reading and writing skills.
Course Objectives	The course aims to impart domain and industry-specific communication skills in a globalized context and to promote the understanding of business communication practices and cross cultural dynamics.
Course Outcomes:	By pursuing this course the students shall be able to
	CO1. Define, describe and classify the modalities and nuances of communication in a workplace context.
	CO2. Review, appraise and understand the modes, contexts and appropriacy of communicating across cultures and societies.
	CO3. Identify, interpret and demonstrate the basic formats, templates of business and official communication.
	CO4. Identify, compare and illustrate reading strategies and basic writing strategies.
	CO5. Interpret, analyze and evaluate semantic-structural, interpersonal and multicultural dynamics in business communication.

Course Content:

Module 1:

Verbal and Nonverbal communication

4 L

Definition, Relevance and Effective Usage

Components of Verbal Communication: Written and Oral Communication

Components of Non-verbal Communication: Kinesics, Proxemics, Chronemics, Haptics Paralanguage

Barriers to Effective Communication

Module 2:

Workplace Communication Essentials and Cross Cultural Communication

4L

Communication at the Workplace—Formal and Informal Situations

Language in Use—Jargon, Speech Acts/Language Functions, Syntactical and Grammatical Appropriacy
Cultural Contexts in Global Business: High Context and Low Context Cultures
Understanding Cultural Nuances and Stereotyping
Achieving Culturally Neutral Communication in Speech and Writing

Module 3:

Reading Strategies and Basic Writing Skills **4L**

Reading: Purposes and Nature of Reading
Reading Sub-Skills—Skimming, Scanning, Intensive Reading
Reading General and Business Texts(Reading for Comprehension and Detailed Understanding)
Basic Writing Skills—Paragraph and Essay writing, writing technical documents
Writing Technicalities—Paragraphing, Sentence Structure and Punctuation

Module 4:

Report Writing **4L**

Nature and Function of Reports
Types of Reports
Researching for a Business Report
Format, Language and Style
Report Documentation

Module 5:

Employment Communication

- a. Writing Business Letters—(Enquiry, Order, Sales, Complaint, Adjustment, Job Application, Offer) **2L**
- b. Creating an Employee Profile-- Preparing a CV or Résumé.
Creating a Digital/Online Profile – LinkedIn (Résumé/Video Profile) **2L**
- c. Writing Other Interoffice Correspondence--E-mails: types, convention, and etiquette, Memo, Notices and Circulars **2L**
- d. Preparing Meeting Documentation—Drafting Notice and Agenda of Meetings, Preparing Minutes of Meetings. **2L**

References :-

1. Meenakshi Raman and Sangeetha Sharma. Technical Communication. 3rd edition. New Delhi:Oxford University Press, 2015.
2. Mark Ibbotson. Cambridge English for Engineering. Cambridge: Cambridge University Press,2008.
3. Mark Ibbotson. Professional English in Use: Engineering. Cambridge: Cambridge UP, 2009.

4. Lesikar et al. *Business Communication: Connecting in a Digital World*. New Delhi: TataMcGraw-Hill, 2014.
5. John Seeley. *Writing Reports*. Oxford: Oxford University Press, 2002.
6. Judith Leigh. *CVs and Job Applications*. Oxford: Oxford University Press, 2002.
7. Judith Leigh. *Organizing and Participating in Meetings*. Oxford: Oxford University Press, 2002.
8. Michael Swan. *Practical English Usage*. Oxford: OUP, 1980.
9. Pickett, Laster and Staples. *Technical English: Writing, Reading & Speaking*. 8th ed. London: Longman, 2001.
10. Diana Booher. *E-writing: 21st Century Tools for Effective Communication*.

Links:-

1. Purdue University's Online Writing Lab (OWL)- <https://owl.purdue.edu/>
2. Business English Pod- <https://www.businessenglishpod.com/>

CO-PO Mapping

	PO1	PO2	PO3	PO4	PO5	PO6	PO7	PO8	PO9	PO 10	PO 11	PO 12
CO.1	-	-	-	-	-	2	1	1	2	3	-	2
CO.2	-	-	-	-	-	1	1	2	2	3	-	3
CO.3	-	-	-	-	-	3	3	1	1	3	2	3
CO.4	-	-	-	-	-	3	3	1	-	3	-	3
CO.5						2	2	2	2	3	-	3

COURSE NAME: VALUES & ETHICS

COURSE CODE: HU202

CONTACT (L: T: P): 2: 0: 0

TOTAL CONTACT HOURS: 24

CREDIT: 2

Prerequisite: Nil

CO1: Understand the core values that shape the ethical behavior of an engineer and Exposed awareness on professional ethics and human values.

CO2: understand the basic perception of profession, professional ethics, various moral issues & uses of ethical theories

CO3: understand various social issues, industrial standards, code of ethics and role of professional ethics in engineering field

CO4: Aware of responsibilities of an engineer for safety and risk benefit analysis, professional rights and responsibilities of an engineer

CO5: Acquire knowledge about various roles of engineers in variety of global issues and able to apply ethical principles to resolve situations that arise in their professional lives

Module 1:

Value: Definition- Importance and application of Value in life- Formation of Value- Process of Socialization- self and integrated personality.

Types of values-Social, Psychological, Aesthetic, Spiritual, and Organizational-Value crisis in contemporary society: individual, societal cultural and management level. (4)

Module-2

Effects of Technological Growth- Rapid Technological growth and depletion of resources, Reports of the Club of Rome.

Problems of Technology transfer- Technology assessment impact analysis.

Human Operator in Engineering projects and industries- Problems of man, machine- interaction- Impact of assembly line and automation-Human centred Technology. (4)

Module-3

Impact of Ethics on Business Policies and Strategies – Utilitarianism – Principles of Utilitarianism - Criticism of Utilitarianism - Impact on Business Culture - Role of CEO in shaping Business Culture – Ethical Leadership – Characteristics (4)

Module-4

Types of Ethical issues - Internal Ethics of Business – Hiring Employees – Promotion - Wages – Job discrimination - its nature and extent- Exploitation of Employees – Discipline and Whistle Blowing (2)

Module-5

Markets and consumer Protection – Consumer rights – Unethical Practices in Marketing – Ethics of Competition and Fair Prices – Ethics in Advertising and False Claims - Environmental Protection and Ethics –Pollution Control – Ecological ethics (4)

Module-6

Social Responsibilities of Business – Definition and case study of Corporate Compliance; Responsibilities towards Customers, shareholders, employees – Social Audit – Objectives and Need for Social Audit – Methods of Social Audit – Benefits – Obstacles – Social Audit in India. (6)

Text Books:

- 1) A N Tripathi, Human values in the Engineering Profession, Monograph published by IIM, Calcutta 1996
- 2) . S. K. Chakraborty: Values and Ethics in Organization, OUP

Reference Books:

- 1) U.C.Mathur, Corporate Governance & Business Ethics, Macmillan, 2005
2. Fernando. A. C., Business Ethics – An Indian Perspective, Pearson Publication, 2009.
- 3) Prem Vir Kapoor, Professional Ethics & Human Values, Khanna Publishing House, New Delhi

CO and PO Mapping

CO \ PO	PO1	PO2	PO3	PO4	PO5	PO6	PO7	PO8	PO9	P10	P11	P12
CO1	-	-	-	-	-	2	-	3		1	2	1
CO2	-	2	-	-	-	1	-	2	3	3	3	2
CO3	-	-	-	-	-	3	3	2	3	1	3	2
CO4		2				3	3		3		3	2
CO5						3					2	

COURSE NAME: CONSTITUTION OF INDIA

COURSE CODE: HU203

CONTACT (L: T: P): 1: 0: 0

TOTAL CONTACT HOURS: 12

CREDIT: 1

Prerequisite: Nil

Course Outcome: On Completion of this course student will be able to

CO1: Identify and explore the basic features and modalities of Indian constitution.

CO2: Differentiate and relate the functioning of Indian parliamentary system at the centre and state level.

CO3: Differentiate the various aspects of Indian Legal System and its related bodies.

Course Content:

Module 1: History of Making of the Indian Constitution: History. Drafting Committee, (Composition & Working)

Philosophy of the Indian Constitution: Preamble Salient Features **3L**

Module 2: Fundamental Rights, Fundamental Duties, Directive Principles of State Policy:
6L

The Right to Equality

The Right to Freedom: I (Article 19)

The Right to Freedom: II (Articles 20, 21 and 22)

The Right against Exploitation

The Right to freedom of Religion

Cultural and Educational rights

The Right to Property

The Right to Constitutional Remedies

Fundamental Duties

Module-3: Organs of Governance: **3L**

Parliament - Composition - Qualifications and Disqualifications -Powers and Functions – Executive- President -Governor - Council of Ministers - Judiciary, Appointment and Transfer of Judges, Qualifications - Powers and Functions

Text Book:

- 1) Indian Constitution by D.D.Basu, The Publisher, LexisNexis
- 2) PM Bhakshi, The constitution of India, Universal Law, 14e, 2017

Reference Books:

- 1) Constitution of India by Subhas C Kasyap, Vitasta Publishing
- 2) The Constitution of India, P.M Bakshi, Universal Law Publishing Co.Ltd, New Delhi, 2003.
- 3) Indian Constitution Text Book - Avasthi, Avasthi, Publisher: LAKSHMI NARAIN AGARWAL
- 4) Introduction to the Constitution of India, Brij Kishore Sharma, PHI

CO-PO mapping:

CO \ PO	PO1	PO2	PO3	PO4	PO5	PO6	PO7	PO8	PO9	P10	P11	P12
CO1	-	-	-	-	-	2	-	3		1	-	
CO2	-	-	-	-	-	1	-	2		3	-	
CO3	-	-	-	-	-	3	-	2		1	-	

COURSE NAME: WORKSHOP AND MANUFACTURING PRACTICES LAB**COURSE CODE: ME291****CONTACT: 0:0:3****CREDITS: 1.5****Prerequisite:** Physics & Mathematics (10+2 Level)

CO1: Gain basic knowledge of Workshop Practice and Safety useful for our daily living.

CO2: Understand the use of Instruments of a pattern shop like Hand Saw, Jack Plain, Chisels etc.

CO3: Apply and performing operations like such as Marking, Cutting etc used in manufacturing processes.

CO4: Analyze the various operations in the Fitting Shop using Hack Saw, various files, Scriber, etc. to understand the concept of tolerances applicable in all kind of manufacturing.

CO5: Get hands on practice of in Welding and apply various machining

processes which give a lot of confidence to manufacture physical prototypes in project works.

Course Content:

3P

(i) Theoretical discussions:

1. Manufacturing Methods- casting, forming, machining, joining, advanced manufacturing methods
2. Fitting operations & power tools
3. Carpentry
4. Welding (arc welding & gas welding), brazing
5. Electrical & Electronics
6. Metal casting
7. CNC machining, Additive manufacturing, 3D Printing
8. Plastic moulding & Glass Cutting

(ii) Workshop Practice:

At least 6 modules should be covered

Module 1 - Machine shop

6P

Typical jobs that may be made in this practice module:

- i. To make a pin from a mild steel rod in a lathe.
- ii. To make rectangular and vee slot in a block of cast iron or mild steel in a shaping and / or milling machine.

Module 2 - Fitting shop

6P

Typical jobs that may be made in this practice module: To make a Gauge from MS plate.

Module 3 – Carpentry Shop

6P

Typical jobs that may be made in this practice module: To make wooden joints and/or a pattern or like.

Module 4 - Welding & Soldering shop

6P

Typical jobs that may be made in this practice module:

- i. Arc Welding: To join two thick (approx 5mm) MS plates by manual metal arc welding.
- ii. Gas Welding: To join two thin mild steel plates or sheets by gas welding.
- iii. House wiring, soft Soldering

Module 5 – Smithy & Casting

6P

Typical jobs that may be made in this practice module:

- i. A simple job of making a square rod from a round bar or similar.
- ii. One/ two green sand moulds to prepare, and a casting be demonstrated.

Module 6 – CNC Machining & Laser Cutting

6P

Typical jobs that may be made in this practice module:

- i. At least one sample shape on mild steel plate should be made using CNC Milling / CNC Lathe Machine
- ii. At least one sample shape on glass should be made using laser cutting machine.

Module 7 – 3D Printing

6P

- i) Exposure to a 3D printing machine,
- ii) 3D printing of at least one sample model using available materials.

Examinations could involve the actual fabrication of simple components, utilizing one or more of the techniques covered above.

Text Books:

1. Hajra Choudhury S.K., Hajra Choudhury A.K. and Nirjhar Roy S.K., –Elements of Workshop Technology, Vol. I 2008 and Vol. II 2010, Media promoters and publishers private limited, Mumbai.
2. Rao P.N., –Manufacturing Technology, Vol. I and Vol. II, Tata McGrawHill House, 2017.

Reference Books:

1. Gowri P., Hariharan and A. Suresh Babu, Manufacturing Technology – I, Pearson Education, 2008.
 2. Roy A. Lindberg, –Processes and Materials of Manufacture, 4th edition, Prentice Hall India, 1998.
 3. Kalpakjian S. and Steven S. Schmid, Manufacturing Engineering and Technology, 4th edition, Pearson Education India Edition, 2002.
 4. Manufacturing Science by A. Ghosh and A.K. Mallick, Wiley Eastern.
- Principles of Metal Cutting/Principles of Machine Tools by G.C. Sen and A. Bhattacharya, New Central Book Agency, Kolkata.

CO-PO/PSO Mapping:

CO Codes	PO 1	PO 2	PO 3	PO 4	PO 5	PO 6	PO 7	PO 8	PO 9	PO1 0	PO1 1	PO1 2	PSO 1	PSO 2	PSO 3
CO1	3						2		2	2					
CO2	3						2		2	2					
CO3	3						2		2	2			2		2
CO4	3						2		2	2			2		2
CO5	3	2	2				2		2	2					

COURSE NAME: PROFESSIONAL COMMUNICATION LAB

COURSE CODE: HU291

CONTACT: 0:0:2

CREDITS: 1

Pre requisites: Basic knowledge of LSRW skills.

Course Objectives: To train the students in acquiring interpersonal communication skills by focussing on language skill acquisition techniques and error feedback.

Course Outcome:

By pursuing this course the students will be able to:

CO1: Recognize, identify and express advanced skills of Technical Communication in English through Language Laboratory.

CO2: Understand, categorize, differentiate and infer listening, speaking, reading and writing skills in societal and professional life.

CO3: Articulate and present the skills necessary to be a competent Interpersonal communicator.

CO4: Deconstruct, appraise and critique communication behaviours.

CO5: Adapt, negotiate and facilitate with multifarious socio-economical and professional arenas with effective communication and interpersonal skills.

Course Contents:

Module 1: Introduction to the Language Lab

- a. The Need for a Language Laboratory
- b. Tasks in the Lab
- c. Writing a Laboratory Note Book

Module 2: Active Listening

- a. What is Active Listening?
- b. Listening Sub-Skills—Predicting, Clarifying, Inferencing, Evaluating, Note-taking
- c. Listening in Business Telephony

Module 3: Speaking

- a. Speaking—Accuracy and Fluency Parameters
- b. Pronunciation Guide—Basics of Sound Scripting, Stress and Intonation
- c. Fluency-focussed activities—JAM, Conversational Role Plays, Speaking using Picture/Audio Visual inputs
- d. Accuracy-focussed activities—Identifying Minimal Pairs, Sound Mazes, Open and Closed Pair Drilling, Student Recordings (using software)
- e. Group Discussion: Principles and Practice
- f. Giving a Presentation—Learning Presentation Basics and Giving Micro Presentations

Module 4: Lab Project Work

- a. Writing a Book Review

- b. Writing a Film Review
- c. Scripting a Short Presentation (2 minutes)
- d. Making a short video CV (1-2 minutes)

References:

1. IIT Mumbai, **Preparatory Course in English** syllabus
2. IIT Mumbai, **Introduction to Linguistics** syllabus
3. Sasikumar et al. *A Course in Listening and Speaking*. New Delhi: Foundation Books, 2005.
4. Tony Lynch, *Study Listening*. Cambridge: Cambridge UP, 2004.

CO-PO Mapping

	PO1	PO2	PO3	PO4	PO5	PO6	PO7	PO8	PO9	PO10	PO11	PO12
CO1	-	-	2	-	-	1	1	-	2	3	-	2
CO2	-	-	2	2	-	3	3	-	2	3	-	3
CO3	-	-	2	2	-	3	3	2	2	3	-	3
CO4	-	-	-	-	-	3	3	2	2	3	-	3
CO5	-	-	2	2	-	3	3	2	2	3	-	3

COURSE NAME: AUTOCAD LAB

COURSE CODE: ME292

CONTACT: 0:0:3

CREDITS: 1.5

Prerequisite: Basic knowledge of Engineering Drawing

Course Outcomes:

CO1: Impart skills in sketching and usage of modern engineering tools necessary in engineering practice.

CO2: Acquire the skill of expressing three -dimensional and two-dimensional objects into professional language and vice versa.

CO3: To enable strong spatial visualization skills which are important to an engineer's ability to create and interpret technical drawings

CO4: Create geometric models of mechanical parts and assemblies employing CAD tool.

Course Contents:

1. Use of solid-modeling software for creating engineering components and assemblies and extracting orthographic views, sectional and Isometric views.
2. To create a 2D view of the parts diagram using Auto CAD.
3. Draw the basic sketch of the solid model.
4. Draw the sketch for the 3D modelling.
5. Draw the sketch of the solid model.
6. Structural analysis for solid model.

Text Book:

Randy H. Shih, Tools for Design Using AutoCAD 2024 and Autodesk Inventor 2024, Hand Sketching, 2D Drawing and 3D Modeling.

CO-PO-PSO Mapping

COs	PO 1	PO 2	PO 3	PO 4	PO 5	PO 6	PO 7	PO 8	PO 9	PO 10	PO 11	PO 12	PSO 1	PSO 2	PSO 3
CO1	2			2									2	2	2
CO2	2			2									2	2	2
CO3	3			2									2	2	2
CO4	3			3									3	3	2
CO5	3	2		3	2								3	3	2

COURSE NAME: ENGINEERING CHEMISTRY LAB

COURSE CODE: CH(ME)291

CONTACT: 0:0:2

CREDITS: 1

Prerequisites: 10+2

Course Objective

- Study the basic principles of pH meter and conductivity meter for different applications
- Analysis of water for its various parameters & its significance in industries
- Learn to synthesis Polymeric materials and drugs
- Study the various reactions in homogeneous and heterogeneous medium

Course Outcome

CH191.1: Able to operate different types of instruments for estimation of small quantities chemicals used in industries and scientific and technical fields.

CH191.2: Able to analyse and determine the composition and physical property of liquid and solid samples when working as an individual and also as a team member

CH191.3: Able to analyse different parameters of water considering environmental issues

CH191.4: Able to synthesize drug and sustainable polymer materials.

CH191.5: Capable to design innovative experiments applying the fundamentals of modern chemistry

CO-PO Mapping

CO	PO1	PO2	PO3	PO4	PO5	PO6	PO7	PO8	PO9	PO10	PO11	PO12
1	3	1	3	1	-	2	3	-	-	-	-	1
2	2	2	1	1	-	1	-	-	-	1	-	1
3	-	-	-	-	-	-	-	-	3	3	2	2
4	2	1	2	2	-	-	1	-	-	-	-	2
5	3	3	3	3	1	1	1	1	-	-	2	2

Course Content:**List of experiment:**

1. Determination of the concentration of the electrolyte through conductance measurement.
2. Determination of water quality measurement techniques.
3. Determination of the concentration of the electrolyte through pH measurement.
4. Estimation of Cu in brass
5. Estimation of Fe₂O₃ in Cement
6. Isolation of graphene from dead dry batteries and their use for temporary soldering.
7. Synthesis of Silver Nanoparticles doped organic thin film for organic transistors.
8. Estimation of corrosion in a given sample metal.
9. Preparation of Si-nano crystals for future memory devices.
10. Green Synthesis of ZnO based Polymer Nano composites.
11. Synthesis of polymers for electrical devices and PCBs.
12. Determination of Partition Coefficient of acetic acid between two immiscible liquids.
13. Drug design and synthesis
14. Rheological properties of the Newtonian fluids
15. Innovative Experiments

2nd Year 1st Semester

Sl. No.	Category	Course Code	Course Title	Hours per week				Credits
				L	T	P	Total	
THEORY								
1	Major	ME301	Engineering Thermodynamics	3	0	0	3	3
2	Major	ME302	Strength of Material	3	0	0	3	3
3	Major	ME303	Manufacturing Process	3	0	0	3	3
4	Minor	M301	Mathematics III	3	0	0	3	3
5	Minor	CS(ME)301	Computer Fundamentals and Programming	3	0	0	3	3
PRACTICAL								
1	Major	ME391	Material Testing Lab	0	0	3	3	1.5
2	Major	ME392	Manufacturing Process Lab	0	0	3	3	1.5
3	Ability Enhancement Course	HU(ME)391	Technical Seminar Presentation	0	0	1	1	0.5
4	Skill Enhancement Course	CS(ME)391	Computer Fundamentals and Programming Lab	0	0	3	3	1.5
TOTAL CREDIT								20

*'Mandatory Additional Requirement'(MAR) activities have to be carried out as per university guidelines.

Detailed Syllabus for 3rd Semester

COURSE NAME: ENGINEERING THERMODYNAMICS

COURSE CODE: ME301

CONTACT: 3:0:0

TOTAL CONTACT HOURS: 36

CREDITS: 3

Prerequisites: Physics (10+2 level)

Course Outcomes:

CO1: Learn about the interrelationship of heat and work to draw an energy balance between a system and its surroundings.

CO2: Understand the second law limitation of energy conversion and differentiate realistic and unrealistic thermodynamic systems.

CO3: Carry out Entropy and Exergy analysis of thermal systems to evaluate sustainability of practical equipment in industries.

CO4: Evaluate the performance of energy conversion devices using utility thermodynamic cycles.

Course Contents

Module	Syllabus	Contact Hours
1. Fundamentals	System & Control volume; Property, State & Process; Exact & Inexact differentials; Work-Thermodynamic definition of work; examples; Displacement work; Path dependence of displacement work and illustrations for simple processes; electrical, magnetic, gravitational, spring and shaft work.	4
2. Temperature & First Law of Thermodynamics	Definition of thermal equilibrium and Zeroth law; Temperature scales; Various Thermometers- Definition of heat; examples of heat/work interaction in systems- First Law for Cyclic & Non- cyclic processes; Concept of total energy E; Demonstration that E is a property; Various modes of energy, Internal energy and Enthalpy.	4
3. Pure Substance	Definition of Pure substance, Ideal Gases and ideal gas mixtures, Real gases and real gas mixtures, Compressibility charts- Properties of two-phase systems - Const. temperature and Const. pressure heating of water; Definitions of saturated states; P-v-T surface; Use of steam tables and R134a tables; Saturation tables; Superheated tables; Identification of states & determination of properties, Mollier's chart.	7
4. First Law for Flow Processes	Derivation of general energy equation for a control volume; Steady state steady flow processes including	5

	throttling; Examples of steady flow devices; Unsteady processes; examples of steady and unsteady I law	
5. Second law of Thermodynamics	Definitions of direct and reverse heat engines; Definitions of thermal efficiency and COP; Kelvin-Planck and Clausius statements; Definition of reversible process; Internal and external irreversibility; Carnot cycle;	5
6. Entropy and its application	Clausius inequality; Definition of entropy S; Demonstration that entropy S is a property; Evaluation of S for solids, liquids, ideal gases and ideal gas mixtures undergoing various processes; Determination of entropy from steam tables- Principle of increase of entropy; Illustration of processes in TS coordinates; Definition of Isentropic efficiency for compressors, turbines and nozzles. Irreversibility and Availability, Availability function for systems and Control volumes undergoing different processes, Lost work. Second law analysis for a control volume. Exergy balance equation and Exergy analysis.	7
7. Thermodynamic cycles	Basic Rankine cycle; Basic Brayton cycle; Basic vapor compression cycle and comparison with Carnot cycle	4
	Total Contact Hours	36

Text Books:

1. Yunus A. Cengel, Michael A. Boles, 2014, 8th Edition, Thermodynamics: An Engineering Approach, McGraw-Hill Education.
2. Nag, P.K, 1995, Engineering Thermodynamics, Tata McGraw-Hill Publishing Co. Ltd.

Reference Books:

1. Sonntag, R. E, Borgnakke, C. and Van Wylen, G. J., 2003, 6th Edition, Fundamentals of Thermodynamics, John Wiley and Sons.
2. Jones, J. B. and Duggan, R. E., 1996, Engineering Thermodynamics, Prentice-Hall of India
3. Moran, M. J. and Shapiro, H. N., 1999, Fundamentals of Engineering Thermodynamics, John Wiley and Sons

CO-PO/PSO Mapping:

COs	PO 1	PO 2	PO 3	PO 4	PO 5	PO 6	PO 7	PO 8	PO 9	PO 10	PO 11	PO 12	PSO 1	PSO 2	PSO 3
CO1	2	2	2	-	-	-	1	-	-	-	-	1	-	2	-
CO2	3	2	2	1	-	-	2	-	-	-	-	-	-	1	-
CO3	3	3	3	1	-	-	3	-	-	-	-	1	-	3	-
CO4	2	1	2	-	-	-	-	-	-	-	-	-	-	2	-
Avg	2.5	2	2.2 5	0.5	-	-	1.5	-	-	-	-	0.5	-	2	-

COURSE NAME: STRENGTH OF MATERIALS

COURSE CODE: ME302

CONTACT: 3:0:0

TOTAL CONTACT HOURS: 36

CREDITS: 3

Prerequisite: Engineering Mechanics

Course Outcomes:

CO1: Recognize various types loads applied on machine components of simple geometry and understand the nature of internal stresses that will develop within the components.

CO2: Evaluate the strains and deformation in materials that will result due to the elastic stresses developed within the materials for simple types of loading.

CO3: Quantify mechanical integrity and failure in materials.

CO4: Analyze application of materials with respect to their strength and weakness.

Course Contents:

Module	Syllabus	Contact Hours
1. Deformation in solids	Hooke's law, stress and strain- tension, compression and shear stresses, elastic constants and their relations- volumetric, linear and shear strains- principal stresses and principal planes- Mohr's circle	7
2. Beams	Beams and types of transverse loading on beams- shear force and bend moment diagrams- Types of beam supports, simply supported and over-hanging beams, cantilevers. Theory of bending of beams, bending stress distribution and neutral axis, shear stress distribution, point and distributed loads.	8
3. Moment of inertia	Moment of inertia about an axis and polar moment of inertia, deflection of a beam using double integration method, computation of slopes and deflection in beams, Maxwell's reciprocal theorems.	5
4. Failure Theorie	Static failure theories: Ductile and brittle failure mechanisms, Tresca, Von-mises, Maximum normal stress, Mohr-Coulomb and Modified Mohr-Coulomb Theory	4
5. Torsion	Torsional stresses and deformation in circular and hollow shafts, stepped shafts, deflection of shafts fixed at both ends, stresses and deflection of helical springs	6
6. Pressure Vessels	Axial and hoop stresses in cylinders subjected to internal pressure, deformation of thick and thin cylinders, deformation in spherical shells subjected to internal pressure	6
	Total Contact Hours	36

Text Books:

1. Egor P. Popov, Engineering Mechanics of Solids, Prentice Hall of India, New Delhi, 2001.
2. R. Subramanian, Strength of Materials, Oxford University Press, 2007.
3. Ferdinand P. Beer, Russel Johnson Jr and John J. Dewole, Mechanics of Materials, Tata Mc Graw Hill Publishing Co. Ltd., New Delhi 2005.

CO – PO/PSO Mapping:

CO	PO 1	PO 2	PO 3	PO 4	PO 5	PO 6	PO 7	PO 8	PO 9	PO 10	PO 11	PO 12	PS O 1	PS O 2	PS O 3
CO1	3	2	2	2	2	-	-	-	-		-	2	2	-	-
CO2	3	2	2	2	2	-	-	-	-		-	2	-	-	-
CO3	2	3	3	-	3	-	-	-	-		-	2	2	-	-
CO4	2	2	3	2	2	-	-	-	-		-	2	2	-	-
Avg	2.5	2.5	2.5	2	2.25	-	-	-	-		-	2	2	-	-

Text Books:

1. Egor P. Popov, Engineering Mechanics of Solids, Prentice Hall of India, New Delhi, 2001.
2. R. Subramanian, Strength of Materials, Oxford University Press, 2007.
3. Ferdinand P. Beer, Russel Johnson Jr and John J. Dewole, Mechanics of Materials, Tata Mc Graw Hill Publishing Co. Ltd., New Delhi 2005.

COURSENAME: MANUFACTURING PROCESSES

COURSE CODE: ME303

CONTACT: 3:0:0

TOTAL CONTACT HOURS: 36

CREDITS:3

Prerequisite: Workshop

Course Outcomes:

CO1: Understand the basics of manufacturing processes and concerned behavior of material properties.

CO2: Explain various casting processes for different molding designs and forming techniques for metal works.

CO3: Understand welding methods and analyze solid or liquid state joining.

CO4: Analyze the principle of powder metallurgy and its application.

Course Contents:

Module	Syllabus	Contact Hours
1. Casting Process	Metal Casting: Casting and Molding: Major Classification, Casting Materials. Sand mould casting: Moulding sands: composition, properties & testing. Design of gating system: sprue, runner, ingate & riser, Estimation of powering time, Foundry equipment, Furnaces Melting, pouring and solidification Type of patterning, use of a core. Different type of sand mould casting: Floor mould casting, Centrifugal casting, Shell mould & CO2 casting, Investment casting. Permanent mould casting: Die casting, types, methods; advantages & applications. Slush casting, principle & use. Casting defects, types, causes & remedy; equipment; Heat transfer and solidification, shrinkage, riser design, casting defects and residual stresses.	10
2. Forming Process	Metal Forming: Plastic deformation and yield criteria; Forging: Introduction, definition, classification, hot forging & cold forging, characteristics & applications. Forging material operations, equipment & tools: Smith forging, Drop forging, Pressing or press forging, Forging dies, materials & design. Rolling: Introduction, basic principles, hot rolling & cold rolling, characteristics & applications. Rolling processes & applications, operations, equipments & roll stands. Wire drawing & extrusion: Basic principles & requirements. Classification, methods & applications. Miscellaneous forming processes. load estimation for bulk forming	10

	(forging, rolling, extrusion, drawing) and sheet forming (shearing, deep drawing, bending).	
3. Joining Process	Metal Joining: Different metal welding processes; types of joints. Gas welding: oxy-acetylene flame; gas welding equipment; welding process. Electric arc welding: principle of arc formation; arc welding equipment- AC & DC machine; electrodes. Manual metal arc welding procedure: edge preparation, current & voltage setting, electrode movement; down hand, horizontal & overhead welding. TIG & MIG welding: process & application. Resistance welding- spot welding & butt/seam welding. Causes & remedy of welding defects, NDT methods.	10
4. Press-tool Works	Press tool works: Basic principles, systems, operations & applications, Shearing, parting, blanking, piercing & notching, Cupping (drawing), Spinning & deep drawing Blanks & forces needed for shearing & drawing operations, Coining & embossing	3
5. Powder Metallurgy	Powder Metallurgy: Principles of powder metallurgy; production of Metallic Powder; processing methods (mixing and blending, compacting, sintering, secondary operations etc.); Advantages; Designing for P/M; Metal injection Moulding (MIM); applications, advantages and limitations.	3
	Total Contact Hours	36

Text Books:

1. Kalpakjian and Schmid, Manufacturing processes for engineering materials (5th Edition)- Pearson India, 2014
2. Mikell P. Groover, Fundamentals of Modern Manufacturing: Materials, Processes and Systems.
3. Degarmo, Black & Kohser, Materials and Processes in Manufacturing

CO – PO/PSO Mapping:

COs	PO 1	PO 2	PO 3	PO 4	PO 5	PO 6	PO 7	PO 8	PO 9	PO 10	PO 11	PO 12	PSO 1	PSO 2	PSO 3
CO 1	3	-	2	-	-	-	-	-	-	-	1	-	1	-	1
CO 2	3	3	3	2	-	-	-	-	-	-	-	-	2	-	2

CO 3	3	2	3	2	-	-	-	-	-	-	-	-	3	-	2
CO 4	3	2	3	2	-	-	-	-	-	-	1	-	2	-	3
Avg	3	1.7 5	2.7 5	1.5	-	-	-	-	-	-	0.5	-	2	-	2

COURSE NAME: COMPUTER FUNDAMENTALS AND PROGRAMMING

COURSE CODE: CS(ME)301

CONTACT: 3:0:0

TOTAL CONTACT HOURS: 36 CREDITS: 3

Prerequisites: Number system, Boolean Algebra

Course Outcome:

- CO1** Understand and differentiate among different programming languages for problem solving.
- CO2** Describe the way of execution and debug programs in C language.
- CO3** Define, select, and compare data types, loops, functions to solve mathematical and scientific problem.
- CO4** Understand the dynamic behavior of memory by the use of pointers.
- CO5** Design and develop modular programs using control structure, selection structure and file.

Course Contents

Module	Syllabus	Cont act Hour s
1. Fundamentals of Computer	History of Computer, Generation of Computer, Classification of Computers, Basic structure of Computer System, Primary & Secondary Memory, Processing Unit, Input & Output devices. Number System: basic of Binary, Octal, Decimal and Hexadecimal number systems; Representation and interchanging of number in different number systems. Introduction to complements system, Representation of signed and unsigned numbers in signed magnitude signed 1's complement system and signed 2's complement system. Arithmetic- Addition and Subtraction (using 1's complement and 2's complement). Representation of Characters-ASCII Code Basics of Compiler, Interpreter and Assembler Problem solving – Basic concept of Algorithm. Representation of algorithm using flow chart and pseudo code. Some basic examples	9

2. Introduction to C Programming	Overview of Procedural vs Structural language; History of C Programming Language. Variable and Data Types: The C characterse identifiers And keywords, data type & sizes, variable names, declaration, statements. Operators & Expressions: Arithmetic operators,relational operators, logical operators, increment anddecrementoperators,bitwiseoperators,assignmentoperators,conditional operators,specialoperators-typeconversion, C expressions, precedence and associativity. Input and Output: Standard input and output, formatted output–print f,formatted input scan f.	5
3. Branch and Loop	Branching: Concept of Statement and Blocks in C, Simple if, if -else, nested if-else and if-else ladder. Switch Case: break and continue; switch-case, concept of go to and labels Loops - while, for, do while	5
4. Program Structures	Function: Basics of Functions, function types, function prototypes, formal and actual parameter, function calling, functions returning values, functions not returning values. Recursion and Recursive Function. Storage Class in C: Storage Class-auto, external, static and register storage class, scope rules and life time of variables C pre-processor: Pre-processing directive and macro, parameterized macro.	4
5. Array and Pointer	Arrays: One dimensional arrays, Two-dimensional arrays, Passing an array to a function Pointers: Pointers, Pointer and Array, Pointer and functions. Strings: Character array and string, array of strings, Passing a string to a function, String related functions, Pointer and String. Dynamic memory allocation: Malloc, calloc, realloc and free with example.	7
6. Structures , Unions and Enum	Basic of structures, arrays of structures, structures and pointers, bit fields. Basics of union and enum, difference between structure and union.	3
7. File in C	Files handling- opening and closing a file in different mode, formatted and unformatted files, Command line arguments, f open, f close, f get c, f put c, f print f, f scan f function	3
Total Contact Hours		36

Textbook:

1. Byron Gottfried, Schaum's Outline of Programming with C, McGraw-Hill
2. Kanetkar Y.-LetusC,BPBPpublication,15th Edition

Reference Books:

1. Brian W. Kernighan and Dennis M. Ritchie, The C Programming Language, Prentice Hall of

CO–PO/PSO Mapping:

PO CO	PO 1	PO 2	PO 3	PO 4	PO 5	PO 6	PO 7	PO 8	PO 9	PO 10	PO 11	PO 12	PSO 1	PSO 2	PSO 3
CO1	3	3	3	2	2								3	3	3
CO2	3	2	2	2	2								3	3	3
CO3	3	3	3	2	2								3	3	3
CO4	3	3	3	2	2								3	3	3
CO5	3	3	3	2	2								3	3	3

COURSE NAME: MATERIALS TESTING LABORATORY

COURSE CODE: ME391

CONTACT: 0:0:3

CREDITS: 1.5

Prerequisites: Engineering Mechanics and Engineering Materials.

Course Outcomes:

CO1: Acquire experimentation skills in the field of material testing.

CO2: Apply the knowledge to analyze a material failure and determine the failure inducing agent/s.

CO3: Apply the knowledge of testing methods in related areas.

CO4: Understand how to improve structure/behavior of materials for various industrial applications.

List of experiments:

At least six experiments need to be conducted.

1. Uniaxial tension test on mild steel rod
2. Torsion test on mild steel rod
3. Impact test on a metallic specimen
4. Brinell and Rockwell hardness tests on metallic specimen
5. Bending deflection test on beams
6. Strain measurement using Rosette strain gauge
7. Microscopic examination of heat-treated and untreated metallic samples
8. Demonstration of Fatigue Test
9. Strut test (Column buckling experiment)
10. Determination of moment of inertia of rotating bodies

CO – PO/PSO Mapping:

COs	PO 1	PO 2	PO 3	PO 4	PO 5	PO 6	PO 7	PO 8	PO 9	PO 10	PO 11	PO 12	PSO 1	PSO 2	PSO 3
CO 1	3	2	2	-	-	-	-	-	-	-	-	2	3	2	2
CO 2	2	2	2	-	-	-	-	-	-	-	-	2	2	2	2
CO 3	2	3	2	-	-	-	2	-	-	-	-	2	2	2	2
CO 4	3	3	3	-	-	-	2	-	-	-	-	2	2	2	2
Avg	2.5	2.5	2.25	-	-	-	2	-	-	-	-	2	2.25	2	2

COURSE NAME: MANUFACTURING PROCESS LAB**COURSE CODE: ME392****CONTACTS: 0: 0: 3****CREDIT: 1.5****Prerequisite: Manufacturing Process****Course Outcome:****CO1:** Learn about patterns and casting of metals**CO2:** Practice forming techniques and modern improvements for sophisticated metal works.**CO3:** Apply the knowledge of welding technology and they can perform arc and gas welding to join the material.**CO3:** Appreciate the role of powder metallurgy component in various field**List of Experiments**

Experiment No	Name of the Experiment
1.	To determine the percentage of clay content in dry sand
2.	To determine the grain fineness number of dry and clay free sand
3.	To determination the compressive strength, splitting strength and shearing strength of green sand by Pendulum Type Universal Strength Testing Machine
4.	To determine the permeability number of greensands, Core sand and Raw sand.
5.	Mould preparation and casting of metals after preparation of suitable moulds
6.	Study of post casting operation like fettling, cleaning, deburring and polishing
7.	Practicing smithy or forging of carbon steels and testing for its property changes

8.	To generate plastic curve of a given metal strip at room temperature and at recrystallization temperature during rolling. Observe the changes in metal characteristic after rolling
9.	To generate plastic curve of a given metal strip at room temperature and at recrystallization temperature during rolling. Observe the changes in metal characteristic after rolling
10.	Laboratory experiments in Fabrication processes to observe effects of varying process parameters in GMAW and SMAW and Testing for Joint defects.
11.	Mechanical Press Working: Blanking & Piercing operation and study of simple, compound and progressive press tool. Hydraulic Press: Deep drawing and extrusion operation.
12.	To Study Various Characteristics of given metal powders and Evaluate Green Density as well as Strength Characteristics (hardness) of Cold-compacted and sintered (Conventional) powder

CO-PO Mapping:

COs	PO 1	PO 2	PO 3	PO 4	PO 5	PO 6	PO 7	PO 8	PO 9	PO 10	PO 11	PO 12	PSO 1	PSO 2	PSO 3
CO 1	3	2	2	-	-	-	-	-	-	-	-	2	3	2	2
CO 2	2	2	2	-	-	-	-	-	-	-	-	2	2	2	2
CO 3	2	3	2	-	-	-	2	-	-	-	-	2	2	2	2
CO 4	3	3	3	-	-	-	2	-	-	-	-	2	2	2	2
Avg	2.5	2.5	2.25	-	-	-	2	-	-	-	-	2	2.25	2	2

COURSENAME: COMPUTER FUNDAMENTALS AND PROGRAMMING LAB

COURSE CODE: CS(ME)391

CONTACT: 0:0:3

CREDITS: 1.5

Prerequisites: Number system, Boolean Algebra

Course Outcomes (COs):

After completion of the course students would be able to,

CO1: Understand and propose appropriate command or function in the running system or developing program for engineering and mathematical problems depending on the platform used even in a changed environment leading to their lifelong learning.

CO2: Identify and propose appropriate data type, arithmetic operators, input/output functions and also conditional statements in designing effective programs to solve complex engineering problem using modern tools.

CO3: Design and develop effective programs for engineering and mathematical problems using iterative statements as well as recursive functions using modular programming approach possibly as a team maintaining proper ethics of collaboration.

CO4: Explain and organize data in arrays, strings and structures and manipulate them through programs and also define pointers of different types and use them in defining self-referential structures and also to construct and use files for reading and writing to and from leading to solution of engineering and mathematical problem.

CO5: Prepare laboratory reports on interpretation of experimental results and analyse it for validating the same maintaining proper ethics of collaboration.

Course Content:

Module-1: Familiarization with some basic commands of DOS and Linux. File handling and Directory structures, file permissions, creating and editing simple C program in different editor and IDE, compilation and execution of C program. Introduction to Code block.

Module-2: Problem based on

- a) Basic data types
- b) Different arithmetic operators.
- c) Print f() and scan f() functions.

Module-3: Problem based on conditional statements using

- a) if-else statements
- b) different relational operators
- c) different logical operators

Module-4: Problem based on

- a) **for** loop
- b) **while** loop
- c) **do-while** loop

Module-5: Problem based on

- a) How to write a menu driven program using **switch-case** statement
- b) How to write a function and passing values to a function
- c) How to write a **recursive function**.

Module-6: Problem based on

- a) How to use **array (both I-Dand2-D)**.
- b) How to pass an **array** to a **function**.

Module-7: Problem based on manipulation of strings in different way.

Module-8: Problem based on

- a) How to handle compound variables in

1. Byron Gottfried, Schaum's Outline of Programming with C, McGraw-Hill
2. Kanetkar Y.- Letus C, BPB Publication,15th Edition

Reference Books:

1. Brian W. Kernighan and Dennis M. Ritchie, The C Programming Language, Prentice Hall of India
2. K R Venugopal & S R Prasad – MASTERING C, TMH, 2nd Edition

CO-PO/PSO Mapping:

CO PO	PO 1	PO 2	PO 3	PO 4	PO 5	PO 6	PO 7	PO 8	PO 9	PO 10	PO 11	PO 12	PSO 1	PSO 2	PSO 3
CO1	3	3	3	3	3								3	3	3
CO2	3	3	2	3	3								3	3	3
CO3	3	3	3	3	3								3	3	3
CO4	3	3	3	3	3								3	3	3
CO5	3	3	3	3	3								3	3	3

2nd Year 2nd Semester

Sl · No.	Category	Course Code	Course Title	Hours per week				Credits
				L	T	P	Total	
THEORY								
1	Major	ME401	Applied Thermodynamics	3	0	0	3	3
2	Major	ME402	Fluid Machinery	3	0	0	3	3
3	Major	ME403	Manufacturing Technology	3	0	0	3	3
4	Major	ME404	Materials Engineering	3	0	0	3	3
5	Minor	CS(ME)405	Data Structure	2	0	0	2	2
6	Minor	EC(ME)401A	Microprocessor in Automation	3	0	0	3	3
		EC(ME)401B	Gas Dynamics & Jet Propulsion					
		CS(ME)401C	Internet of Things					
PRACTICAL								
1	Major	ME491	Fluid Mechanics & Fluid Machines Lab	0	0	3	3	1.5
2	Major	ME492	Machine Drawing	0	0	3	3	1.5
3	Major	ME493	Manufacturing Technology Lab	0	0	3	3	1.5
4	Ability Enhancement Course	HU(ME)491	Quantitative Aptitude	1	0	0	1	0.5
TOTAL CREDIT								22

*'Mandatory Additional Requirement'(MAR) activities have to be carried out as per university guidelines.

Detailed Syllabus for 2nd Year 2nd Semester

COURSE NAME: APPLIED THERMODYNAMICS

COURSE CODE: ME401

CONTACT: 3:0:0

TOTAL CONTACT HOURS:36

CREDITS:3

Prerequisite: Engineering Thermodynamics

Course Outcomes:

CO1: Understand fuel characteristics and apply the principles of combustion analysis in combustors.

CO2: Analyze vapor & gas based power cycles and evaluate their performance

CO3: Analyze the functioning and performance of various compressors and refrigeration cycles.

CO4: Demonstrate phenomena occurring in high-speed compressible flows and analyze energy conversion in various thermal devices like nozzles, diffusers and air coolers.

Course Contents

Module	Syllabus	Contact Hours
1. Fuels and Combustion Analysis	Introduction to solid, liquid and gaseous fuels – Stoichiometry, exhaust gas analysis - First law analysis of combustion reactions Heat calculations using enthalpy tables- Adiabatic flame temperature- Chemical equilibrium and composition calculations using free energy	6
2. Vapor Based Cycles	Vapor power cycles, Rankine cycle with superheat, reheat and regeneration, exergy analysis. Supercritical and ultra-supercritical Rankine cycle - Vapor compression refrigeration cycles, refrigerants and their properties	8
3. Gas Based Cycles	Gas power cycles, Air standard Otto, Diesel and Dual cycles – Air standard Brayton cycle, effect of reheat, regeneration and intercooling- Combined gas and vapor power cycles	8
4. Psychrometry	Properties of dry and wet air, use of psychrometric chart, processes involving heating/cooling and humidification/dehumidification, dew point.	4
5. Reciprocating Compressors	Reciprocating compressors, staging of reciprocating compressors, optimal stage pressure ratio, effect of intercooling, minimum work for multistage reciprocating compressors.	5

6. Nozzle and Diffuser	Isentropic flow of a perfect gas through a nozzle, choked flow, subsonic and supersonic flows- Flow of steam and refrigerant through nozzle, supersaturation, compressible flow in diffusers, efficiency of nozzle and diffuser	5
Total Contact Hours		36

Text Books:

1. Sonntag, R. E, Borgnakke, C. and Van Wylen, G.J., 2003,6thEdition, Fundamentals of Thermodynamics, John Wiley and Sons.
2. Nag, P. K,1995, Engineering Thermodynamics, Tata McGraw-HillPublishing Co. Ltd

Reference Books

1. Jones, J. B. and Duggan,R. E., 1996,EngineeringThermodynamics,Prentice-HallofIndia
2. Moran, M. J.and Shapiro, H. N.,1999, Fundamentals of Engineering Thermodynamics, John Wiley and Sons

CO–PO/PSO Mapping:

COs	PO 1	PO 2	PO 3	PO 4	PO 5	PO 6	PO 7	PO 8	PO 9	PO 10	PO 11	PO 12	PSO 1	PSO 2	PSO 3
CO 1	3	2	2	2	-	-	2	-	-	-	-	2	3	-	-
CO 2	2	2	2	3	-	-	2	-	-	-	-	2	2	-	-
CO 3	3	3	2	3	-	-	2	-	-	-	-	2	2	-	-
CO 4	2	3	2	2	-	-	2	-	-	-	-	2	2	-	-
Avg	2.5	2.5	2	2.5	-	-	2	-	-	-	-	2	1.75	-	-

COURSE NAME: FLUID MACHINERY

COURSE CODE: ME402

CONTACT: 3:0:0

TOTAL CONTACT HOURS: 36

CREDITS: 3

Prerequisite: Fluid Mechanics

Course Outcomes: At the end of the course the students will be able to

CO1: Discuss the characteristics of centrifugal pump and reciprocating pumps

CO2: Calculate forces and work done by a jet on fixed or moving plate and curved plates

CO3: Analyze the working of turbines and select the type of turbine for an application.

CO4: Evaluate hydraulic machines and select the suitable one for a specific application

Course Contents:

Module	Syllabus	Contact Hours
1. Impact of Jets and Jet Propulsions	Euler's fundamental equation, Force exerted by a liquid jet on a stationary flat plate, force exerted by a liquid jet on a stationary curved vane, force exerted by a liquid jet on a hinged plate, force exerted by a liquid jet on moving flat plates, force exerted by a liquid jet on moving curved vane, jet propulsion.	4
2. Hydraulic Turbines	Essential element of a hydroelectric power plant; head and efficiencies of hydraulic turbines; classifications of hydraulic turbines, Pelton turbine, reaction turbine, Francis turbine, Kaplan turbine; draft tube; cavitation in hydraulic machines; dimensional analysis and similarity laws for rotodynamic machines; specific speed of hydraulic turbines; unit quantities of hydraulic turbines; characteristic curves of hydraulic turbines; governing of Pelton wheel and turbines.	8
3. Centrifugal Pump	Components of a centrifugal pump, working principle, work done by impeller, different heads in a pumping system, different efficiencies, characteristics, minimum speed for starting a centrifugal pump, multistage centrifugal pumps, specific speed, model testing, cavitation & separation, net positive suction head	8
4. Positive Displacement Pump:	Components of a reciprocating pump, working principle, types of reciprocating pumps, discharge and power requirement, slip and coefficient of discharge, variation of velocity and acceleration in the suction and delivery pipes due to acceleration of the piston, frictional head on suction and delivery pipes, indicator diagram, air vessels. Comparison of centrifugal and reciprocating pumps, Performance characteristics.	8

5. Miscellaneous Hydraulic Machines:	Hydraulic press, hydraulic accumulator, hydraulic intensifier, hydraulic ram, hydraulic lift, hydraulic crane, hydraulic coupling, hydraulic torque converter, hydraulic actuators, hydraulic valves, air lift pump, jet pump.	8
Total Contact Hours		36

Text Books:

1. A textbook on Fluid Mechanics and Hydraulic Machines – Sukumar Pati, TMH
2. Fluid Mechanics & Machinery – R. K. Bansal, Luxmi Publications.
3. Introduction to Fluid Mechanics & Fluid Machines – Som Biswas, Chakraborty, TMH.
4. Fluid Mechanics & Turbo Machines – M.M. Das, PHI, 2010.
5. Fluid Mechanics and Fluid Power Engineering by D S Kumar, S K Kataria & Sons

Reference Books:

1. Fluid Mechanics & Machinery – C. Ratnam, A.V. Kothapalli, I.K. International Publishing House Ltd, 2010.
2. Fluid Mechanics & Machinery – C.S.P Ojha, R. Berndtsson, P.N. Chandramouli, OUP.
3. Introduction to Fluid Mechanics – Fox & Macdonald, Wiley.
4. Fluid Mechanics – Fundamentals & Applications – Cengel & Cimbala, TMH.

CO – PO/PSO Mapping:

COs	P O 1	P O 2	P O 3	P O 4	P O 5	P O 6	P O 7	P O 8	P O 9	P O 10	P O 11	P O 12	P S O 1	P S O 2	P S O 3
CO1	3	2	3	1	-	1	3	-	2	-	-	-	2	3	-
CO2	3	3	2	2	-	1	1	-	1	-	-	-	2	2	-
CO3	2	2	2	2	-	1	2	-	3	-	-	-	2	3	-
CO4	2	3	2	-	1	1	1	-	1	-	-	-	2	2	-
Avg	2.5	2.5	2.2 5	1.2 5	0.2 5	1	1.7 5	-	1.7 5	-	-	-	2	2.5	-

COURSE NAME: MANUFACTURING TECHNOLOGY

COURSE CODE: ME403

CONTACT: 3:0:0

TOTAL CONTACT HOURS: 36

CREDITS: 3

Prerequisite: Manufacturing Processes, Materials Engineering.

Course Outcomes: After successful completion of this course, the learner will be able to:

- CO1:** Understand the cutting tool geometry, mechanism and mechanics of machining, cutting temperature and application of cutting fluids, tool life and tool materials.
- CO2:** Understand the basic operations and kinematic structure of machine tools needed for manufacturing.
- CO3:** Explore and use the knowledge of the assembly of different components in practical projects.
- CO4:** Apply the optimization methods in manufacturing.

Course Contents:

Module	Syllabus	Contact Hours
1. Machining Principles	Machining: Basic principle, definition and requirements. Cutting Tools: Geometry of single point and multi point tools in ASA, ORS and NRS systems, Conversion of tool angles. Mechanism and Mechanics of machining: Chip formation in various cutting and determination of various force components. Cutting temperature and cutting fluids. Tool Life: Tool wear and tool life, Surface finish and integrity, Machinability, Cutting tool materials.	12
2. Machine Tools	Introduction, Purpose of use, definition and general features of machine tools. Generatrix and Directrix and tool-work motions in different operations of conventional machine tools. Major components and their functions for shaping, planning and slotting machines; drilling and milling machines; and lathe. Kinematic structure of conventional and non-conventional machine tools.	10
4. Mechanical Assembly	Manufacturing and assembly, alignment and testing methods, tolerance analysis, process planning, selective assembly, Material handling and devices	4
5. Optimization	Linear programming, objective function and constraints, graphical method, Simplex algorithms, transportation assignment, Network models: shortest route, minimal spanning tree, maximum flow model-Project networks: CPM and PERT, critical path scheduling; Production planning& control: Forecasting models, aggregate production planning, materials requirement planning.	10
Total Contact Hours		36

Text Books:

1. A. B. Chattopadhyay, Machining and Machine Tools, Wiley India (P) Ltd., New Delhi.
2. G. Kuppuswamy, Principles of Metal Cutting, University Press, Hyderabad.
3. Stephenson & Agapion, Metal Cutting Theory and Practice, Taylor and Francis, NY.
4. G.C. Sen and A. Bhattacharyya, Principles of Machine Tools, New Central Book Agency (P)Ltd., Kolkata.

CO-PO/PSO Mapping:

COs	PO 1	PO 2	PO 3	PO 4	PO 5	PO 6	PO 7	PO 8	PO 9	PO 10	PO 11	PO 12	PSO 1	PSO 2	PSO 3
CO1	3	3	3	2			2	-	2		-		3		2
CO2	3	2	2	2			2	-	2		-		2		2
CO3	3	3	2	2			2	-	2		-		3		2
CO4	3	2	-	-			-	-	3		2		3		2

COURSE NAME: MATERIALS ENGINEERING**COURSECODE:ME404****CONTACT: 3:0:0****TOTAL CONTACT HOURS: 36****CREDITS:3**

CO1: Identify crystal structures for various materials and understand the defects in such structures.

CO2: Analyze the effect of heat treatment of mechanical properties of a material.

CO3: Understand how to tailor material properties of ferrous and nonferrous alloys

CO4: Learn about advanced materials useful in modern industrial application.

Prerequisite: Engineering Physics and Engineering Chemistry

Course Contents:

Module	Syllabus	Contact Hours
1. Crystal Structure	Unit cells, Metallic crystal structures, Imperfection in solids: Point, line, interfacial and volume defects; dislocation strengthening mechanisms and slip systems, critically resolved shear stress	6
2. Mechanical Property measurement	Tensile, compression and torsion tests; Young's modulus, relations between true and engineering stress-strain curves, generalized Hooke's law, yielding and yield strength, ductility, resilience, toughness and elastic recovery; Hardness: Rockwell, Brinell, Vickers and their relation to strength.	7
3. Metals & Alloys	Alloys, substitutional and interstitial solid solutions- Phase diagrams: Interpretation of binary phase diagrams and microstructure development; Iron - Iron-carbide phase diagram, and microstructure analysis of ferrous materials, cast iron, steel.	6
4. Heat treatment	Heat treatment of Steel: Annealing, tempering, normalising and spheroidising, isothermal transformation diagrams for Fe-C alloys and microstructure development. Continuous cooling curves and interpretation of final microstructures and properties- austempering, martempering, case hardening, carburizing, nitriding, cyaniding, carbonitriding, flame and induction hardening, vacuum and plasma hardening	7
5. Alloying of steel	Properties of stainless steel and tool steels, maraging steels- cast irons; - copper and copper alloys; brass, bronze and cupro-nickel; Aluminum and Al -Cu – Mg alloys- Nickel based superalloys and Titanium alloys	5
6. Ceramics and Advanced Materials	Structure, properties and application of ceramics, Composite Types, Types and properties of main composition, Smart Materials, Ferroelastic and Piezoelectric materials, Nanomaterials, Biomaterials, Shape memory alloys	5
Total Contact Hours		36

Text Books:

1. W. D. Callister, 2006, Materials Science and Engineering - An Introduction, 6th Edition, Wiley India.
2. V. Raghavan, Material Science and Engineering, Prentice Hall of India Private Limited, 1999.
3. U. C. Jindal, Engineering Materials and Metallurgy, Pearson, 2011.

Reference Books:

1. Kenneth G. Budinski and Michael K. Budinski, Engineering Materials, Prentice Hall of India Private Limited, 4th Indian Reprint, 2002.

CO-PO/PSO Mapping:

COs	PO 2	PO 2	PO 3	PO 4	PO 5	PO 6	PO 7	PO 8	PO 9	PO 10	PO 11	PO 12	PSO 1	PSO 2	PSO 3
CO 1	2	2	2	2	1	-	-	-	-	-	-	1	-	3	2
CO 2	2	2	3	2	1	-	-	-	-	-	-	2	-	3	2
CO 3	3	3	3	2	1	-	-	-	-	-	-	2	-	2	2
CO 4	2	1	3	2	1	-	-	-	-	-	-	2	-	2	2
Avg	2.2 5	2	2.7 5	2	1	-	-	-	-	-	-	1.7 5	-	2.5	2

COURSE NAME: DATA STRUCTURE**COURSE CODE: CS(ME)405****CONTACT: 2:0:0****TOTAL CONTACT HOURS: 24****CREDITS: 2**

Prerequisite: C language

Course outcomes:

CO1: For a given algorithm student will able to analyze the algorithms to determine the time and computation complexity and justify the correctness.

CO2: For a given Search problem (Linear Search and Binary Search) student will able to implement it.

CO3: For a given problem of Stacks, Queues and linked list student will able to implement it and analyze the same to determine the time and computation complexity.

CO4: Students will able to write algorithms and practice programming in C++.

Course contents:

Module	Syllabus	Contact Hours
I – Introduction	Basic Terminologies: Elementary Data Organizations, Data Structure Operations: insertion, deletion, traversal etc.; Analysis of an Algorithm, Asymptotic Notations, Time-Space trade off. Searching: Linear Search and Binary Search Techniques and their complexity analysis.	5
II – Stacks and Queues	ADT Stack and its operations: Algorithms and their complexity analysis, Applications of Stacks: Expression Conversion and evaluation – corresponding algorithms and complexity analysis. ADT queue, Types of Queue: Simple Queue, Circular Queue, Priority Queue; Operations on each types of Queues: Algorithms and their analysis.	5
III – Linked Lists and Trees	Singly linked lists: Representation in memory, Algorithms of several operations: Traversing, Searching, Insertion into, Deletion from linked list; Linked representation of Stack and Queue, Header nodes, Doubly linked list: operations on it and algorithmic analysis; Trees: Basic Tree Terminologies, Different types of Trees: Binary Tree, Threaded Binary Tree, Binary Search Tree, AVL Tree; Tree operations on each of the trees and their algorithms with complexity analysis. Applications of Binary Trees. B Tree, B+ Tree: definitions, algorithms and analysis.	8
IV– Sorting and Hashing	Sorting and Hashing: Objective and properties of different sorting algorithms: Selection Sort, Bubble Sort, Insertion Sort, Quick Sort, Merge Sort, Heap Sort; Performance and Comparison among all the methods, Hashing.	4
V – C++	Object oriented Programming using C++	2
	Total Contact Hours	24

Text Book:

1. —Fundamentals of Data Structures, Illustrated Edition by Ellis Horowitz, Sartaj Sahni, Computer Science Press.

Reference books:

1. Algorithms, Data Structures, and Problem Solving with C++, Illustrated Edition by Mark Allen

Weiss, Addison-Wesley Publishing Company

2. —How to Solve it by Computer, 2nd Impression by R.G. Dromey, Pearson Education

CO – PO/PSO Mapping:

CO	PO 1	PO 2	PO 3	PO 4	PO 5	PO 6	PO 7	PO 8	PO 9	PO 10	PO 11	PO 12	PSO 1	PSO 2	PSO 3
CO1	2	1	1	-	-	-	-	-	-	1	1	1	-	-	-
CO2	1	1	-	-	-	-	-	-	-	1	1	-	-	1	-
CO3	1	1	-	-	-	-	-	-	-	1	1	1	2	-	2
CO4	2	1	1	2	-	-	-	-	-	1	2	-	2	1	-

COURSE NAME: GAS DYNAMICS & JET PROPULSION

COURSE CODE: EC(ME)401B

CONTACT: 3:0:0

CONTACT HOURS: 36

CREDITS: 3

Course Outcomes: On successful completion of the course, the learner will be able to

CO1. Understand the basics of compressible flow.

CO2. Analyze compressible flow characteristics in constant and variable area ducts.

CO3. Apply the knowledge of shock theories in complex engineering situations.

CO4. Evaluate jet and rocket propulsion techniques applicable in aerospace industries.

Prerequisite: Fluid Mechanics, Thermodynamics.

Course Contents:

Module	Syllabus	Contact Hours
1. COMPRESSIBLE FLOW - FUNDAMENTALS	Energy and momentum equations for compressible fluid flows - various regions of flows - reference velocities - stagnation state - velocity of sound - critical states - Mach number – critical Mach number - types of waves - Mach cone - Mach angle - effect of Mach number on flow.	6
2. FLOW THROUGH VARIABLE AREA DUCTS	Isentropic flow through variable area ducts- T-s and h-s diagrams for nozzle and diffuser flows - Area ratio as a function of Mach number - Mass flow rate through nozzles and diffusers - Effect of friction in flow through nozzles.	7
3. FLOW THROUGH CONSTANT AREA DUCTS	Flow in constant area ducts with friction (Fanno flow) – Fanno curves and Fanno flow equation - variation of flow properties - variation of Mach number with duct length. Isothermal flow with friction in constant area ducts. Flow in constant area ducts with heat transfer (Rayleigh flow) - Rayleigh line and Rayleigh flow equation - variation of flow properties - Maximum heat transfer.	6
4. NORMAL AND OBLIQUE SHOCKS	Governing equations – Variation of flow parameters across the normal and oblique shocks – Prandtl – Meyer relations – Applications	9
5. PROPULSION	Jet Propulsion: Aircraft propulsion - types of jet engines – energy flow through jet engines- performance of turbo jet engines - thrust - thrust power - propulsive and overall efficiencies – thrust augmentation in turbo jet engine - ram jet, pulse jet and turboprop Engines. Space Propulsion: Types of rocket engines - Propellants - Ignition and combustion - Theory of rocket propulsion –Terminal and characteristic velocity - Applications.	8
Total Contact Hours		36

Text Books

1. YAHYA. S.M. - "Fundamental of compressible flow"- New Age International (p) Ltd. - New Delhi 1996.
2. PATRICH.H. OOSTHVIZEN-WILLIAM E. CARSCALLEN- "Compressible fluid flow"-

McGraw-Hill- 1997

3. COHEN. H. - ROGERS R.E.C AND SRAVANAMUTOO- "Gas turbine theory"- Addison Wesley Ltd. - 1987.

4. GANESAN. V. - "Gas Turbines"- Tata McGraw-Hill- New Delhi- 1999

Reference Books

1. RATHAKRISHNAN.E- "Gas Dynamics"- Prentice Hall of India- New Delhi- 2001

2. HILL.D and PETERSON .C, Mechanics & Thermodynamics of propulsion - Addison Wesley Publishing Company, 1999.

3. G.P. Sutton- "Rocket Propulsion Elements "- John Wiley- 1986- New York.

4. ZUCROW N.J Principles of Jet Propulsion and Gas Turbines - John Wiley Newyork, 1970

CO-PO/PSO Mapping:

CO	PO 1	PO 2	PO 3	PO 4	PO 5	PO 6	PO 7	PO 8	PO 9	PO 10	PO 11	PO 12	PSO 1	PSO 2	PSO 3
CO1	3	2	2	2	2	2	3	1	1	1	1	3	2	3	1
CO2	2	1	2	1	2	2	3	1	1	1	1	2	1	2	2
CO3	2	1	1	1	2	2	3	1	1	1	1	2	1	2	3
CO4	1	1	1	1	3	2	3	1	2	1	2	3	1	2	3

COURSE NAME: FLUID MECHANICS & FLUID MACHINES LAB

COURSE CODE: ME491

CONTACT: 0: 0: 3

CREDITS: 1.5

PREREQUISITES: FLUID MECHANICS & MACHINERY

Course outcome:

CO1: Develop a hands-on grasp of fluid behavior principles through experiments, covering pressure, velocity, and flow dynamics.

CO2: Gain expertise in using instruments like manometers, pitot tubes, and viscometers for accurate fluid parameter measurement and data interpretation.

CO3: Acquire skills to assess pump, turbine, and hydraulic system performance, analyzing efficiency, head, and power characteristics.

CO4: Learn experimental design, execution, and reporting techniques, cultivating the ability to present findings systematically and conclusively.

List of Experiments:

1. Measurement of Coefficient of Discharge of an Orifice
2. Measurement of Coefficient of Discharge of a Venturimeter
3. To verify the Bernoulli's Theorem
4. To find the critical Reynolds number for pipe flow
5. To determine friction factor for a flow through pipe
6. Determination of the density & viscosity of an oil and friction factor of oil flow in a pipe
7. Determination of the performance characteristics of a centrifugal pump
8. Determination of the performance characteristics of a Pelton Wheel
9. Determination of the performance characteristics of a Francis Turbine.
10. Determination of the performance characteristics of a Kaplan Turbine

Course Name: Machine Drawing

Course Code: ME492

Contact: 0:0:3

Credits: 1.5

Prerequisite: Basic knowledge of Machine elements, engineering drawing/drafting

Course Outcomes:

CO1: Gain knowledge about the isometric views of a given three-dimensional object/part.

CO2: Understand and draw the orthogonal projection of a solid body and assemble drawing using part drawings.

CO3: Learn and practice 3D modeling of machine parts using AutoCAD /

SOLIDWORKS /CATIA

CO4: Draft the shape and structure of different types of screws, keys and Couplings

List of Experiments

1. Schematic product symbols for standard components in welding and pipe joints
2. Joints 2 Orthographic projections of machine elements, different sectional views- full, auxiliary sections, Isometric projection of components (Manual and CAD).
3. Assembly and detailed drawings of a mechanical assembly (Manual Drafting) a) Plummer block b) Tool head of a shaping machine c) Tailstock of a lathe d) Welded pipe joints indicating work parts before welding
4. Basic 3D modeling practice of simple machine elements using AutoCAD or SolidWorks (At least 10, samples given)

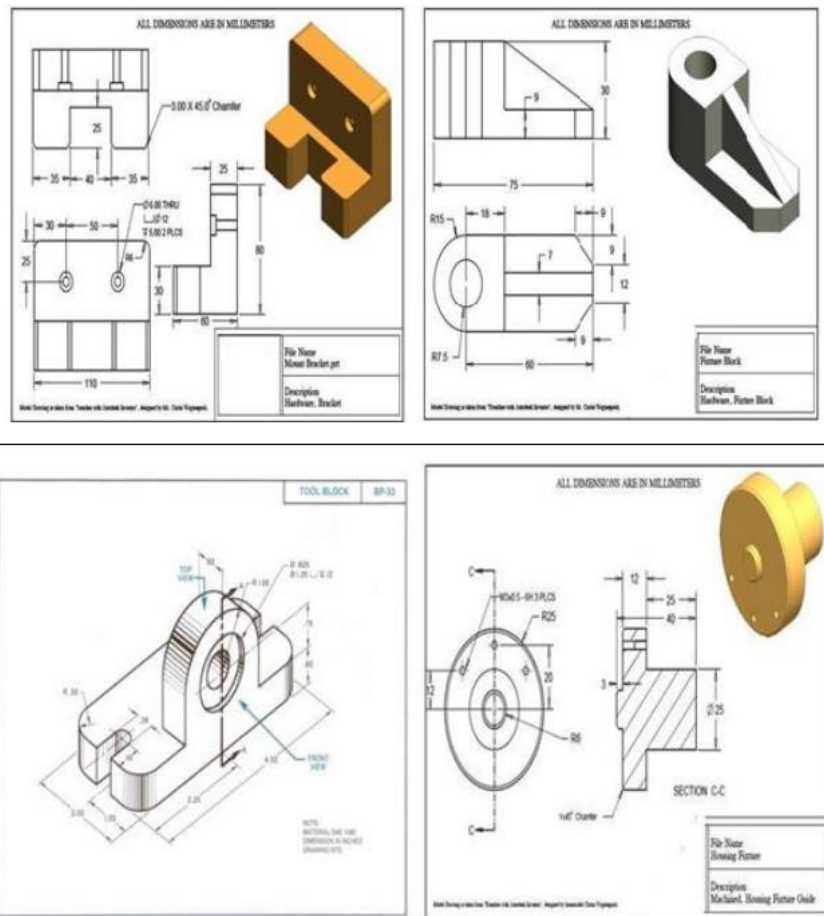

Text Books:

1. Text Book on Engineering Drawing, Narayana/Kannaia H, Scitech
2. Mechanical Engineering Drawing and Design, S. Pal and M. Bhattacharyya
3. Machine Drawing by N.D. Bhatt
4. Machine Drawing by P.S. Gill
5. Engineering Drawing and Graphics + AutoCAD by K. Venugopal, New Age

International Pub.

6. Engineering Drawing with an Introduction to AutoCAD by D.A. Jolhe, Tata-McGraw-Hill Co.
7. Introduction to Solid Modeling Using SolidWorks 2008, Joseph C. Musto and William E.Howard
8. SOLIDWORKS 2016 Basic Tools, Paul Tran.

CO-PO/PSO Mapping:

CO s	P O 1	P O 2	P O 3	P O 4	P O 5	P O 6	P O 7	P O 8	P O 9	P O 10	P O 11	PO 1 2	P S O 1	P S O 2	PS O 3
CO 1	1	2	2	-	-	-	-	-	-	-	-	-	2	-	1
CO 2	1	2	2	-	-	-	-	-	-	-	-	-	1	-	-
CO 3	1	3	2	-	-	-	-	-	-	-	-	-	1	-	1
CO 4	2	2	1	-	-	-	-	-	-	-	-	-	1	-	1
Avg	1.2 5	2.2 5	1.7 5	-	-	-	-	-	-	-	-	-	1.25	-	0.7 5

COURSENAME: MANUFACTURING TECHNOLOGY LAB

COURSECODE: ME493

CONTACTS: 0: 0: 3

CREDITS: 1.5

Prerequisite: Manufacturing Technology

CO1: Develop proficiency in operating machining tools, mastering techniques for precise material removal and dimensional accuracy.

CO2: Gain hands-on experience in using a variety of machine tools, understanding their functions, capabilities, and applications in production processes.

CO3: Learn principles of efficient assembly, including component alignment, joining methods, and quality verification for producing functional products.

CO4: Acquire the ability to analyze manufacturing processes, identify areas for improvement, and propose solutions for enhanced product quality and production efficiency.

List of Experiments

At least 6 (six) of the following experiments/ assignments to be conducted

1. Taper turning and external thread cutting using lathe
2. Contour milling using vertical milling machine
3. Spur gear cutting in milling machine
4. Measurement of cutting forces in Milling/ Turning process
5. Measurement of average cutting temperature in turning under different speed – feed combinations
6. Measurement of surface roughness in turning under different conditions
7. Study of chip formation (type, color & thickness) in turning mild steel and evaluation of role of variation of cutting velocity and feed on chip reduction coefficient /cutting ratio and shear angle
8. Measurement of tool – wear and evaluation of tool life in turning mild steel by HSS or carbide tool
9. Bore diameter measurement using micrometer and telescopic gauge

CO-PO/PSO Mapping:

COs	PO 1	PO 2	PO 3	PO 4	PO 5	PO 6	PO 7	PO 8	PO 9	PO 10	PO 11	PO 12	PSO 1	PSO 2	PSO 3
CO1	2	2	3	2	-	-	2	-	1	-	3	-	2	-	2
CO2	3	3	2	2	-	-	2	-	-	-	3	-	2	-	2
CO3	3	2	2	2	-	-	2	-	-	-	3	-	2	-	2
CO4	3	3	2	2	-	-	2	-	1	-	3	-	2	-	2
Avr g.	2.7 5	2.5	2.2 5	2	-	-		-		-	3	-	2	-	2

3rd Year 1st Semester

Sl. No.	Category	Course Code	Course Title	Hours per week				Credits
				L	T	P	Total	
THEORY								
1	Major	ME501	Heat Transfer	3	0	0	3	3
2	Major	ME502	Kinematics & Dynamics of Machines	3	0	0	3	3
3	Major	ME503	A. Refrigeration and Air Conditioning B. Finite Element Analysis C. Metrology & Measurement	3	0	0	3	3
4	Minor	EC(ME)501A	Mechatronics Systems	3	0	1	4	4
		EE(ME)501B	Fluid Power control					
		CS(ME)501C	Data Base Management System					
PRACTICAL								
1	Major	ME591	Heat Transfer Lab	0	0	3	3	1.5
2	Major	ME592	Kinematics & Dynamics of Machines Lab	0	0	3	3	1.5
3	Major	ME593	A. Refrigeration and Air Conditioning Lab B. Finite Element Analysis Lab C. Metrology & Measurement Lab	0	0	3	3	1.5
4	Minor	EC(ME)591A	Mechatronics Systems Lab	0	0	2	2	1
		EE(ME)591B	Fluid Power Control Lab					
		CS(ME)591C	Data Base Management System Lab					
5	Ability Enhancement	HU(ME)591	Soft Skill -I	1	0	0	1	0.5

	Course							
6	VAC	ME594	Modeling & Simulation of Mechanical Systems	0	0	2	2	0.5
7	Project	ME581	Minor Project I	0	0	2	2	1
TOTAL CREDIT								20.5

*‘Mandatory Additional Requirement’(MAR) activities have to be carried out as per university guidelines.

COURSE NAME: HEAT TRANSFER

COURSE CODE: ME 501

CONTACT: 3:0:0

TOTAL CONTACTHOURS: 36

CREDITS: 3

Prerequisite: Thermodynamics, Fluid mechanics.

Course Outcomes:

CO1: Understand the basic laws & constraints of heat transfer to analyze problems involving steady state or transient heat conduction in simple geometries.

CO2: Survey the analytical solutions of free and forced convection problems to apply in modern research sectors of heat and mass transfer.

CO3: Evaluate the radiation heat transfer between black body and gray body surfaces and obtain numerical solutions of combined mode heat transfer problems in practice.

CO4: Analyze the effectiveness of several type of heat exchanger and develop skills for industrial design solutions regarding boiling and condensation.

Course Contents:

Module No.	Syllabus	Contact Hrs.
1 Conduction	Introduction to three modes of heat transfer, Derivation of heat balance equation- Steady one dimensional solution for conduction heat transfer in Cartesian, cylindrical and spherical geometry, concept of conduction and film resistances, critical insulation thickness, lumped system approximation and Biot number, heat transfer through pin fins- Two dimensional conduction solutions for both steady and unsteady heat transfer- approximate solution to unsteady conduction heat transfer by the use of Heissler charts	10

2 Convection	Heat convection, basic equations, boundary layers- Forced convection, external and internal flows-Natural convective heat transfer- Dimensionless parameters for forced and free convection heat transfer-Correlations for forced and free convection- Approximate solutions to laminar boundary layer equations (momentum and energy) for both internal and external flow- Estimating heat transfer rates in laminar and turbulent flow situations using appropriate correlations for free and forced convection.	9
3 Radiation	Interaction of radiation with materials, definitions of radiative properties, Stefan Boltzmann's law, black and gray body radiation, Calculation of radiation heat transfer between surfaces using radiative properties, view factors and the radiosity method	7
4 Heat Exchangers	Types of heat exchangers, Analysis and design of heat exchangers using both LMTD and ϵ -NTU methods.	5
5 Boiling & Condensation	Boiling and Condensation heat transfer, Pool boiling curve.	3
6 Mass Transfer	Introduction to mass transfer, Similarity between heat and mass transfer.	2

Text Books:

1. P.K. Nag, Heat & Mass Transfer, TMH.
2. Yunus A Cengel, Heat Transfer: A Practical Approach, McGraw Hill, 2002

Reference Books:

1. S.K. Som, Introduction to Heat Transfer, PHI.
2. Kreith, Principles of Heat Transfer, Cengage learning.
3. O.P. Single, Heat & Mass Transfer, Macmillan India.

CO – PO/PSO Mapping:

COs	PO 1	PO 2	PO 3	PO 4	PO 5	PO 6	PO 7	PO 8	PO 9	PO 10	PO 11	PO 12	PSO 1	PSO 2	PSO 3
CO1	3	3	1	3	-	1	1	-	-	-	2	1	3	2	-
CO2	3	3	2	3	-	1	1	-	-	-	1	2	3	2	-
CO3	2	2	1	2	-	1	1	-	-	-	1	1	3	2	-

CO4	3	2	2	3	-	2	2	-	-	-	2	2	3	2	2
-----	---	---	---	---	---	---	---	---	---	---	---	---	---	---	---

COURSE NAME: KINEMATICS & DYNAMICS OF MACHINES

CODE: ME 502

CONTACT: 3:0:0

TOTAL CONTACTHOURS: 36

CREDITS: 3

Prerequisite: Physics

Course Outcomes:

CO1: Understand the kinematics and rigid- body dynamics of kinematically driven machine components

CO2: Understand the motion of linked mechanisms in terms of the displacement, velocity and acceleration at any point in a rigid link

CO3: Design and analyse cam and gear based mechanisms to generate specified output motion

CO4: Explore the mechanism of bearings and understand vibration-based systems

Course Contents:

Module	Syllabus	ContactHrs
1– Mechanisms	Classification of mechanisms- Basic kinematic concepts and definitions- Degree of freedom, mobility- Grashof's law, Kinematic inversions of four bar chain and slider crank chains Limit positions- Mechanical advantage- Transmission angle- Description of some common mechanisms- Quick return mechanism, straight line generators- Universal Joint- Rocker mechanisms	6

2– Velocit y& Acceleration	Displacement, velocity and acceleration analysis of simple mechanisms, graphical velocity analysis using instantaneous centers, velocity and acceleration analysis using loop closure equations- kinematic analysis of simple mechanisms- slider crank mechanism dynamics- Coincident points- Coriolis component of acceleration- introduction to linkage synthesis three position graphical synthesis for motion and path generation	8
3– Cam Drive	Classification of cams and followers- Terminology and definitions- Displacement diagrams, Uniform velocity, parabolic, simple harmonic and cycloidal motions- derivatives of follower motions- specified contour cams- circular and tangent cams- pressure angle and undercutting, sizing of cams, graphical and analytical disc cam profile synthesis for roller and flat face followers	6
4- Gear Drive	Involute and cycloidal gear profiles, gear parameters, fundamental law of gearing and conjugate action, spur gear contact ratio and interference/undercutting- helical, bevel, worm, rack & pinion gears, epicyclic and regular gear train kinematics.	6
5- Friction & Bearings	Introduction to Bearing, Classification; Sliding contact bearing & Rolling Contact bearing, Lubrication in different bearing material, 'Balancing' in Mechanical components, Gyroscope.	6
6 - Vibration	Natural and Transverse vibration, Free and forced Vibration, Damping, Torsional vibration	4
Total Hours (36 L)		

Text Books:

1. Thomas Bevan, Theory of Machines, 3rd edition, CBS Publishers & Distributors, 2005.
2. Ghosh A. and Mallick A.K., Theory of Mechanisms and Machines, Affiliated East West Pvt. Ltd, New Delhi, 1988.

Reference Books:

1. Cleghorn W.L., Mechanisms of Machines, Oxford University Press, 2005.
2. Robert L. Norton, Kinematics and Dynamics of Machinery, Tata Mc Graw Hill, 2009.

CO – PO/PSO Mapping:

COs	PO 1	PO 2	PO 3	PO 4	PO 5	PO 6	PO 7	PO 8	PO 9	PO 10	PO 11	PO 12	PSO 1	PSO 2	PSO 3
CO1	3	3	2	2	-	-	-	-	-	-	-	-	-	-	-
CO2	3	2	3	1	-	-	-	-	-	-	2	1	2	-	-

CO3	2	2	2	-	2	-	-	-	-	-	-	-	-	2	-
CO4	3	3	2	-	-	-	-	-	-	-	3	2	2	-	3

COURSE NAME: REFRIGERATION & AIR CONDITIONING

COURSE CODE: ME503A

CONTACT: 3:0:0

TOTAL

CONTACTHOURS:36

CREDITS:3

Prerequisite: Applied Thermodynamics

Course Outcomes:

CO1: Explain different types of Refrigeration cycles and its applications in multi compressor and multi evaporator systems.

CO2: Evaluate the selection and design of different components of Refrigeration systems

CO3: Interpret the knowledge of psychometric processes and air conditioning systems.

CO4: Design the air-conditioning system for a given conditions including refrigerating equipment as well as ducting systems.

Course Contents:

Module No.	Syllabus	Contact Hrs.
1 Refrigerants	Classification of refrigeration systems, Refrigerants and their mixtures: properties and characteristics; Ozone depletion and global warming issues	3
2 VCRS	Advanced Vapor compression cycles Compressors, Condensers, Expansion devices and Evaporators-Performance matching of components of refrigeration systems	8

3 VARS	Vapour Absorption Refrigeration System, Advanced sorption refrigeration systems and their components, Lithium bromide - water System; Aqua-ammonia systems.	6
4 ARS	Air Refrigeration System (ARS): Bell-Coleman refrigerator. COP determination, actual air refrigeration cycle.	4
4 Air Conditionin g	Review of Psychrometry and Air-conditioning processes- Comfort air conditioning and Cooling load calculations - Applications of AC systems	10
5 Application & Duct Design	Concept of enthalpy potential - Air washers, Cooling towers, Evaporative condensers, Cooling and dehumidifying coils, Duct Sizing & Design	6
Total Hours (36 L)		

Text Books:

1. Stocker & Jones, Refrigeration and Air Conditioning, McGraw Hill.
2. P. L. Ballaney, Refrigeration and Air Conditioning.

Reference Books:

3. R. C. Arora, Refrigeration and Air Conditioning, TMH.
4. Arora and Domkundwar, Refrigeration and Air Conditioning, Dhanpat Rai Publication.

CO – PO/PSO Mapping:

COs	PO 1	PO 2	PO 3	PO 4	PO 5	PO 6	PO 7	PO 8	PO 9	PO 10	PO 11	PO 12	PSO 1	PSO 2	PSO 3
CO1	3	3	2	1	-	1	1	-	-	1	1	-	-	-	-
CO2	2	-	2	-	-	1	3	1	-	1	2	1	2	-	3
CO3	2	2	2	-	-	-	-	-	-	1	1	-	2	-	2
CO4	3	1	3	1	-	1	2	-	-	1	2	2	2	-	3

COURSE NAME: FINITE ELEMENT ANALYSIS

COURSE CODE: ME503B

CONTACT: 3:0:0

TOTAL CONTACTHOURS: 36

CREDIT: 3

PREREQUISITE: MATHEMATICS III.

Course Outcomes:

CO1: Understand the fundamental theory of the FEA method.

CO2: Develop the ability to generate the governing FE equations for systems governed by partial differential equations.

CO3: Apply the basic finite element methods for structural applications using truss, beam, frame, and plane elements.

CO4: Analyze the FE method and compare the results with FEA package like ANSYS.

Course Contents:

Module No.	Syllabus	Contact Hrs.
1.	Introduction: Historical background, Relevance of FEM to design problems, Application to the continuum– Discretization, Matrix approach, Matrix algebra– Gaussian elimination, Governing equations for continuum, Classical Techniques in FEM, Weighted residual method, Ritz method, Galerkin method.	8

2.	One dimensional problems: Finite element modeling– Coordinates and shape functions, Potential energy approach– Element matrices and vectors, Assembly for global equations, Boundary conditions, Higher order elements- Shapes functions, Applications to axial loadings of rods– Extension to plane trusses, Bending of beams– Finite element formulation of stiffness matrix and load vectors, Assembly to Global equations, boundary conditions, Solutions and Post processing, Example Problems.	8
3.	Two dimensional problems– scalar variable problems: Finite element modeling– CST element, Element equations, Load vectors and boundary conditions, Assembly, Application to heat transfer, Examples.	4
4.	Two dimensional problems– vector variable problems: Vector Variable problems, Elasticity equations– Plane Stress, Plane Strain and Axisymmetric problems, Formulation, element matrices, Assembly, boundary conditions and solutions. Examples	8
5.	Isoparametric elements for two dimensional problems: Natural coordinates, Iso parametric elements, Four node quadrilateral element, Shape functions, Element stiffness matrix and force vector, Numerical integration, Stiffness integration, Displacement and Stress calculations, Examples.	6
6.	Computer implementation: Pre-processor, Processor, Post-processor. Discussion about finite element packages.	2
Total		36

Text Books:

1. David Hutton, Fundamentals of Finite element Analysis, 2st Edition
2. C.S. Krishnamoorthy, Finite Element Analysis, TMH.

Reference books.

1. J. Bathe, Finite Element Procedures, Prentice Hall.
2. O.C. Zienkiewicz, R.L. Taylor, J.Z. Zhu, The Finite Element Method: Its Basis and Fundamentals, Elsevier.
3. J.N. Reddy, An Introduction to the Finite Element Method, McGraw-Hill.

CO – PO/PSO Mapping:

CO	PO 1	PO 2	PO 3	PO 4	PO 5	PO 6	PO 7	PO 8	PO 9	PO 10	PO 11	PO 12	PSO 1	PSO 2	PSO 3
CO1	2	-	2	2	3	-	-	1	-	-	-	3	3	-	-
CO2	2	3	-	3	2	-	-	1	-	-	-	2	3	-	-
CO3	3	3	-	2	2	-	-	1	-	-	-	2	3	-	-
CO4	-	-	-	1	2	-	-	1	-	-	-	2	3	-	2

COURSE NAME: METROLOGY AND MEASUREMENT

COURSE CODE: ME503C

CONTACT: 3:0:0

TOTAL CONTACTHOURS: 36

CREDIT: 3

Prerequisite: Knowledge of basic science upto 12th

Course Outcomes: Upon successful completion of this course, students will be able to

CO1: Obtain knowledge about different instruments used to measure pressure, temperature, flow, level of liquids and data acquisition etc.

CO2: Elucidate the construction and working of various industrial devices used to measure pressure, sound and flow.

CO3: Explicate the construction and working of various industrial devices used to measure temperature, level, vibration, viscosity and humidity.

CO4: Ability to analyze, formulate and select suitable sensor for the given industrial applications.

Course Contents:

Module No.	Syllabus	Contact Hrs.
-------------------	-----------------	---------------------

1.	Introduction: Definition and importance of Metrology Measurement; Methods of measurements – direct, indirect, comparison, substitution, transposition, deflection and null measurement; Errors in measurement – absolute, relative, parallax, alignment, loading, dynamic and calibration error; Units of measurements – SI base and derived units, SI prefixes of units.	3
2.A	Linear Metrology: Vernier scale; construction and use of Vernier calliper, Vernier height and depth gauge, micrometer; slip gauge.	3
2.B	Angular Metrology: Constructional features and use of protractor, Vernier bevel protractor, angle gauges, sine bar and slip gauges.	2
2.C	Measurements of : (i) Level using spirit-level; (ii) Flatness using straight edge, interferometry (Newton's rings) and surface plate; Parallelism, cylindricity and concentricity using dial indicator.	3
3.	Interchangeability of components; concept of limits, tolerances and fits; Hole basis and shaft basis system of fits; Go and No Go limit gauges; plug, ring, snap, thread, radius and filler gauges.	5
4.	Definition, use and essential features of Comparators; working principle and application of (i) dial gauge, (ii) Cook optical comparator, (iii) back pressure Bourdon gauge pneumatic comparator, (iv) optical comparator-profile projector.	4
5.	Measuring Instruments: Functional elements of an instrument – sensing, conversion & manipulation, data transmission and presentation element; Characteristics – accuracy, precision, repeatability, sensitivity, reproducibility, linearity, threshold, calibration, response, dynamic or measurement error; Transducers – definition, primary and secondary, active and passive.	5
6.	Measurement of Surface Finish: Definition; Terminologies – geometrical surface, effective surface, surface roughness, roughness (primary texture), waviness (secondary texture), form, lay, sampling length; Numerical evaluation of surface roughness: peak-to-valley height (Rmax), centre line average (CLA, Ra), average depth (Rm), smoothness value (G); Principle of operation of a Talysurf.	4
7.	Principle of operation of a few measuring instruments: displacement by LVDT; force by strain – gauge load cell and piezoelectric load cell; pressure by Bourdon – tube gauge; temperature by liquid-in-glass thermometer, thermocouples, optical pyrometer; liquid velocity by pitot tube; water flow by orifice meter.	7
Total		36L

Text Book

1. E.O. Doebelin and D.N. Manik, Measurement Systems– Application and Design, TMH

2. R. Rajendra, Principles of Engineering Metrology, Jaico Pub. House.

Reference Book

1. Beckwith, Lienhard and Marangoni, Mechanical Measurements, Pearson.
2. Bewoor and Kulkarni, Metrology & Measurement, TMH.
3. R.K. Jain, Metrology, Khanna Publication, New Delhi.

CO – PO/PSO Mapping:

COs	PO 1	PO 2	PO 3	PO 4	PO 5	PO 6	PO 7	PO 8	PO 9	PO 10	PO 11	PO 12	PSO 1	PSO 2	PSO 3
CO1	1	2	-	2	1	-	2	2	-	2	-	-	2	-	3
CO2	2	1	2	-	-	1	2	1	1	1	-	-	-	3	-
CO3	3	2	-	2	1	-	2	2	-	1	-	-	3	-	-
CO4	3	-	2	-	-	2	-	3	-	2	-	-	-	2	-

COURSE NAME: MECHATRONICS SYSTEM

COURSE CODE: EC(ME)501A

CONTACT: 3:0:0

TOTAL CONTACTHOURS:36

CREDIT: 3

Prerequisite: Fluid Mechanics, Basic Electronics.

Course Outcomes

- CO1: Describe Mechatronics systems and have an overview of the types of actuators.
 CO2: Distinguish between various sensors, transducers, actuators and their applications.
 CO3: Understand the basic concept of microprocessor.
 CO4: Interpret various signal conditioning units, amplifiers, logic gates and their role in Programmable logic controllers.

Course Contents:

Module No.	Syllabus	Contact Hrs.
1.	Introduction to Mechatronics: Definition, Mechatronics in design and manufacturing, Comparison between Traditional and Mechatronic approach; Concurrent engineering.	3
2.	Review of fundamentals of electronics, Logic gates and their operations, Signal processing devices, Data conversion devices, Input and output devices. Sensors and Transducers, Actuators, Limit	6

	switches, Relays.	
3.	Control Systems: Open loop and closed loop control, block diagrams, transfer functions, Laplace transforms.	3
4.	Electrical Drives: Stepper motors, servo drives.	2
5.	Mechanical Drives: Different mechanisms, Ball screws, Linear motion bearings, Transfer systems.	3
6.	Pneumatic and Hydraulic Drives: Elements of pneumatic and hydraulic drives, comparison between them. Design of pneumatic and hydraulic circuits, symbolic representations of such circuits indicating different valves, actuators, etc.	4
7.	Basics of 8085 microprocessor, programmable register architecture, buses, memory mapping, clock pulse and data transfer operations, and simple assembly and mnemonic programming on 8085 microprocessor.	5
8.	Use of On-Off, PI and PID controllers to control different drives, Programming in PLC controller using Ladder diagram.	4
9.	Mathematical modeling of physical systems, such as spring-mass vibration system, linear and rotary motion and its Laplace Transform.	2
10.	Basics of time domain analysis, Introduction to discrete-time systems and Z-transform.	2
11.	Introduction to Mechatronic systems, such as automatic brake, door closing and opening, robot, CNC machine, AGV, etc.	2
Total Lectures		36 L

Text Book

1. N.P. Mahalik, Mechatronics, Tata McGraw Hill Publication
2. W. Bolton, Mechatronics, Pearson Education

Reference Book

1. Smaili and F. Arnold, Mechatronics, Oxford University Press, Indian Edition
2. M.D. Singh and J.G. Joshi, Mechatronics, Prentice Hall of India Pvt. Ltd.
3. K.K. AppuKuttan, Mechatronics, Oxford University Press, New Delhi

CO-PO/PSO MAPPING:

COs	PO 1	PO 2	PO 3	PO 4	PO 5	PO 6	PO 7	PO 8	PO 9	PO 10	PO 11	PO 12	PSO 1	PSO 2	PSO 3
CO1	2	-	-	-	1	-	-	-	-	-	-	1	1	1	2
CO2	3	1	2	-	2	-	1	-	-	-	1	2	2	1	1

CO3	2	-	1	-	2	-	-	-	-	-	-	2	3	2	2
CO4	3	2	2	-	3	-	1	-	-	-	3	2	3	2	1

COURSE NAME: FLUID POWER CONTROL

COURSE CODE: EE(ME)501B

CONTACT: 3:0:0

TOTAL CONTACT HOURS: 36

CREDITS: 3

Prerequisite: Fluid Mechanics, Basic Electronics.

Course Outcomes:

CO1: Understand the working principle of hydraulic and pneumatic systems.

CO2: Analyze the performance of pumps and actuators used in control devices.

CO3: Apply hydraulic valves in different industrial application.

CO4: Design and evaluate fluid powered control circuits and express through proper drawing.

Course Contents:

Module No.	Syllabus	Contact Hrs.
-------------------	-----------------	---------------------

1	<p>Introduction: Introduction to Fluid power; Hydraulic power generation and transmission. Applications and advantages; Components of a hydraulic and pneumatic system. Desired properties of a hydraulic fluid; advantage of mineral oil over water; definition of terms like pressure, head, force, density, specific gravity, kinematic and absolute viscosity, compressibility and incompressibility, Pascal's law; analysis of simple hydraulic jack, Mechanical advantage; continuity equation; hydraulic power of a cylinder.</p>	6
2	<p>Hydraulic pumps, accumulators and intensifiers: Classification of pumps, pumping theory of positive displacement pumps, construction and working of Gear pumps, Vane pumps, Piston pumps, fixed and variable displacement pumps, Pump performance characteristics, pump selection factors, problems on pumps. Accumulators: Types, selection/design procedure, applications of accumulators. Types of Intensifiers, Pressure switches/sensor, Temperature switches/sensor, Level sensor.</p>	6
3	<p>Actuators: Classification cylinder and hydraulic motors, Hydraulic cylinders, single and double acting cylinder, mounting arrangements, cushioning, special types of cylinders, problems on cylinders. Construction and working of rotary actuators such as gear, vane, piston motors, and Hydraulic Motor. Theoretical torque, power, flow rate, and hydraulic motor performance; numerical problems. Symbolic representation of hydraulic actuators. Application of cylinder through mechanical linkages; force, velocity and Power from a cylinder.</p>	7
4	<p>Components and hydraulic circuit design Components Classification of control valves, Directional Control Valves-symbolic representation, sliding spool, solenoid and pilot operated DCV, shuttle valve, and check valves. Pressure control valves – types, direct operated types and pilot operated types. Flow Control Valves -compensated and non-compensated FCV, needle valve, temperature compensated, pressure compensated, pressure and temperature compensated FCV, symbolic representation. Hydraulic Circuit Design: Control of single and Double -acting hydraulic cylinder, hydraulic cylinder sequencing circuits, cylinder synchronizing circuit using different methods, hydraulic circuit for force multiplication; speed control of hydraulic cylinder-metering in, metering out and bleed off circuits. Pilot pressure operated circuits. Hydraulic circuit examples with accumulator</p>	7

5	<p>Pneumatic control circuits: Simple Pneumatic Control: Direct and indirect actuation pneumatic cylinders, speed control of cylinders – supply air throttling and exhaust air throttling. Signal Processing Elements: Use of Logic gates – OR and AND gates in pneumatic applications. Practical examples involving the use of logic gates.</p> <p>Multi- Cylinder Application: Coordinated and sequential motion control, motion and control diagrams. Signal elimination methods, Cascading method principle, Practical application examples (up to two cylinders) using cascading method (using reversing valves).</p>	6
6	<p>Electro- Pneumatic Control Principles – signal input and output, pilot assisted solenoid control of directional control valves, use of relay and contactors. Control circuitry for simple signal cylinder application. Give an overview of control systems associated with Electro hydraulic and pneumatic applications.</p>	4
Total		36 L

Text Books:

1. Anthony Esposito, Fluid Power with applications, Prentice Hall international, 1997.
2. Ahmed Abu Hanieh, Fluid Power Control: Hydraulics and pneumatics, Cambridge International Science Publishing.

Reference Book:

1. Andrew Parr, Hydraulics and pneumatics, Jaico Publishing House, 2003.

CO – PO/PSO Mapping:

COs	PO 1	PO 2	PO 3	PO 4	PO 5	PO 6	PO 7	PO 8	PO 9	PO 10	PO 11	PO 12	PSO 1	PSO 2	PSO 3
CO1	3	2	2	1	-	-	-	-	-	1	1	-	-	1	-
CO2	2	-	1	2	1	-	-	1	-	1	2	1	2	2	1
CO3	2	2	2	1	1	1	-	-	-	1	1	1	-	1	1
CO4	2	1	2	2	1	1	-	1	-	1	2	3	2	2	-

COURSE NAME: DATABASE MANAGEMENT SYSTEM

COURSE CODE: CS(ME) 501C

CONTACT: 3:0:0

TOTAL CONTACT HOURS: 36

CREDITS: 3

Prerequisites:

1. Logic of programming language
2. Basic concepts of data structure and algorithms

Course Outcome(s): On completion of the course students will be able to

CO1: Understand the database management system and database language

CO2: Understand and apply the SQL queries related to management of data and transaction processing.

CO3: Explain about query processing techniques involved in query optimization

CO4: Understand PL/SQL programming, the concept of Cursor Management, Error Handling, Package and Triggers

CO5: Design and build the commercial database systems.

Course Contents:

Module No.	Syllabus	Contact Hrs.
1 Introduction	Concept & Overview of DBMS, Data Models, Database Languages, Database Administrator, Database Users, Three Schema architecture of DBMS.	3
2 Entity-Relationship and Relational Database Model	Basic concepts, Design Issues, Mapping Constraints, Keys, Entity-Relationship Diagram, Weak Entity Sets, Extended E-R features, case study on E-R Model. Structure of relational Databases, Relational Algebra, Relational Calculus, Extended Relational Algebra Operations, Views, Modifications Of the Database.	9
3 SQL and Integrity Constraints	Concept of DDL, DML, DCL. Basic Structure, Set operations, Aggregate Functions, Null Values, Domain Constraints, Referential Integrity Constraints, assertions, views, Nested Subqueries, Database security application development using SQL, Stored procedures and triggers.	6
4 Relational Database Design	Functional Dependency, Different anomalies in designing a Database., Normalization using functional dependencies, Decomposition, Boyce-Codd Normal Form, 3NF, Normalization using multi-valued dependencies, 4NF, 5NF , Case Study	6
5 Internals of RDBMS	Physical data structures, Query optimization: join algorithm, statistics and cost bas optimization. Transaction processing, Concurrency control and Recovery Management: transaction model properties, state serializability, lock base protocols; two phase locking, Dead Lock handling	6
6 File Organization & Index Structures	File & Record Concept, Placing file records on Disk, Fixed and Variable sized Records, Types of Single-Level Index (primary, secondary, clustering), Multilevel Indexes	6

Total Hours (36 L)

Text Books:

1. Henry F. Korth and Silberschatz Abraham, —Database System Concepts, Mc.Graw Hill.
2. Elmasri Ramez and Navathe Shamkant, —Fundamentals of Database Systems, Benjamin Cummings

Publishing. Company.

Reference Books:

1. Jain: Advanced Database Management System CyberTech
2. Date C. J., —Introduction to Database Management, Vol. I, II, III, Addison Wesley.
3. —Fundamentals of Database Systems, Ramez Elmasri, Shamkant B.Navathe, Addison Wesley Publishing Edition
4. Gray Jim and Reuter Address, —Transaction Processing : Concepts and Techniques, Moragan Kauffman Publishers.
5. Ullman JD., —Principles of Database Systems, Galgottia Publication.

CO- PO/PSO Mapping

CO Codes	PO 1	PO 2	PO 3	PO 4	PO 5	PO 6	PO 7	PO 8	PO 9	PO 10	PO 11	PO 12	PSO 1	PSO 2	PSO 3
CO1	3	3	3	3	1	2	-	-	2	1	2	-	-	-	-
CO2	3	3	3	3	1	1	-	-	-	1	3	1	2	-	1
CO3	3	3	2	2	2	2	-	-	-	1	2	-	-	-	-
CO4	3	3	3	3	1	1	-	-	-	1	3	-	1	-	1
CO5	3	3	3	3	3	2	1	1	1						

COURSE NAME: HEAT TRANSFER LAB

COURSE CODE: ME591

CONTACT: 0: 0: 3

CREDITS: 1.5

Prerequisite: Heat Transfer.

Course Outcomes:

CO1: Evaluate the problems involving steady state conduction in simple geometries.

CO2: Determine the convective heat transfer for free and forced convection related problems.

CO3: Differentiate radiation capabilities of black and grey surfaces by practical observation

CO4: Analyze the effectiveness of heat exchanger and develop skills for industrial design solutions.

Course Outcomes:

List of Experiments:

1. Determination of the thermal conductivity and specific heat of given objects
2. Determination of the thermal conductivity of insulating materials
3. Determine the overall heat transfer coefficient of the composite wall
4. Determination of thermal conductivity of liquid.
5. Determination of the convective heat transfer coefficient for flow over a heated plate
6. Determination of the average theoretical and experimental value of heat transfer coefficient for forced convection.
7. Determination of the emissivity of a given sample.
8. Determination of the Stefan Boltzmann constant for radiation heat transfer.
9. Determination of the effectiveness of a shell and tube heat exchanger.
10. Determination of the LMTD, effectiveness of parallel and counter flow heat exchanger.

CO – PO/PSO Mapping:

COs	PO 1	PO 2	PO 3	PO 4	PO 5	PO 6	PO 7	PO 8	PO 9	PO 10	PO 11	PO 12	PSO 1	PSO 2	PSO 3
CO1	2	-	1	-	-	-	-	-	2	1	3	2	-	1	-
CO2	2	-	3	-	-		1	-	2	2	3	2	-	2	2
CO3	2	-	1	-	-	1		-	2	1	3	2	-	1	-
CO4	2	-	1	1	-	-	-	-	2	2	3	2	-	2	3

COURSE NAME: KINEMATICS AND DYNAMICS OF MACHINES LAB**COURSE CODE: ME592****CONTACT: 0:0:3****CREDITS: 1.5****Prerequisite:** Kinematics & Theory of Machines.**Course Outcomes:**

- CO1: Understand the kinematics and rigid- body dynamics of kinematically driven machine components
- CO2: Understand the motion of linked mechanisms in terms of the displacement, velocity and acceleration at any point in a rigid link
- CO3: Design and analyse cam and gear based mechanisms to generate specified output motion
- CO4: Explore the mechanism of bearings and understand vibration-based systems

List of Experiment:

1. Velocity ratios of simple, compound, epicyclic and differential gear trains
2. Kinematics of four bar, slider crank, crank rocker, double crank, double rocker and

- oscillating cylinder mechanisms
- 3. Study of Cam & follower motion
- 4. Determination of natural frequency and damping coefficient for a Single DOF Spring-mass-damper system
- 5. Determination of torsional natural frequency of single and double rotor systems-undamped and Damped natural frequencies

CO – PO/PSO Mapping:

COs	PO 1	PO 2	PO 3	PO 4	PO 5	PO 6	PO 7	PO 8	PO 9	PO 10	PO 11	PO 12	PSO 1	PSO 2	PSO 3
CO1	3	3	2	2	-	-	-	-	-	-	-	-	-	-	-
CO2	3	2	3	1	-	-	-	-	-	-	2	1	2	-	-
CO3	2	2	2	-	2	-	-	-	-	-	-	-	-	2	-
CO4	3	3	2	-	-	-	-	-	-	-	3	2	2	-	3

COURSE NAME: REFRIGERATION & AIR CONDITIONING LAB

COURSE CODE: ME593A

CONTACTS: 0: 0: 3

CREDITS: 1.5

Prerequisite: Applied Thermodynamics, Refrigeration & Air Conditioning.

Course Outcomes: On successful completion of the course, the learner will be able to,

CO1. Demonstrate a domestic refrigerator and identify its important components.

CO 2. Analyze the performance parameters of a vapor compression-based refrigeration system

CO 3. Observe the components of a basic air conditioning setup and operate it to analyze its performance index.

CO 4. Recognize the components of a thermoelectric refrigeration setup and measure its coefficient of performance useful in future project applications.

List of Experiments

1. Study of a Domestic Refrigerator.
2. Study of a room (window type) Air Conditioner.
3. Study of a room (split type) Air Conditioner.
4. Determination of C.O.P of a vapour compression refrigeration system.
5. Experiment in an Air Conditioning Test Unit; Determination of bypass factor and plotting of the cooling – dehumidification process on a psychometric chart.
6. Performance test of thermoelectric refrigeration system

CO – PO/PSO Mapping:

COs	PO 1	PO 2	PO 3	PO 4	PO 5	PO 6	PO 7	PO 8	PO 9	PO 10	PO 11	PO 12	PSO 1	PSO 2	PSO 3
CO1	1	-	-	-	-	1	-	-	3	2	3	2	-	-	2
CO2	1	-	2	-	-	-	-	-	3	2	3	3	1	1	2
CO3	1	-	2	-	1	1	1	-	3	2	3	2	1	1	2
CO4	1	-	1	-	1	-	2	-	2	2	3	3	2	-	3

COURSE NAME: FINITE ELEMENT ANALYSIS LAB

COURSE CODE: ME593 B

CONTACTS: 0: 0: 3

CREDITS: 1.5

Prerequisite: Mathematics I & II

Course Outcomes: Upon successful completion of this course, students will be able to

- 1) Understand the fundamental theory of the FEA.
- 2) Generate the governing FE equations for systems governed by partial differential equations.
- 3) Use the finite element methods for structural applications using truss, beam frame, and plane elements.
- 4) Analyze the FE method and compare result with FEA package like-ANSYS.

Course Contents:

1. Introduction to software employed in modelling and analyzing of structural problems.
2. Ten (10) relevant problems shall be modelled and analyzed using ABAQUS software.

CO – PO/PSO Mapping:

CO	PO 1	PO 2	PO 3	PO 4	PO 5	PO 6	PO 7	PO 8	PO 9	PO 10	PO 11	PO 12	PSO 1	PSO 2	PSO 3
CO1	2	-	2	2	-	-	-	1	1	2	3	1	2	-	-
CO2	2	3	-	3	2	-	-	1	2	2	3	1	2	2	-
CO3	3	3	2	2	2	-	-	1	1	2	3	3	-	3	-
CO4	-	-	3	1	3	-	-	1	2	2	3	3	2	-	2

COURSE NAME: METROLOGY & MEASUREMENT LAB

COURSE CODE: ME593C

CONTACTS: 0:0:3

CREDITS: 1.5

Prerequisite: Metrology & Measurement Theory, Physics.

Course Outcomes: Upon successful completion of this course, students will be able to

CO1: Obtain knowledge about different instruments used to measure pressure, temperature, flow, level of liquids and data acquisition etc.

CO2: Elucidate the construction and working of various industrial devices used to measure pressure, sound and flow

CO3: Explicate the construction and working of various industrial devices used to measure temperature, level, vibration, viscosity and humidity

CO4: Ability to analyze, formulate and select suitable sensor for the given industrial applications

Course Contents: List of Experiments

1. Taking measurements using following instruments :
 - (i) Vernier height & depth gauge, (ii) Dial micrometer, (iii) Thread gauge, (iv) Radius gauge, (v) Fillergauge, (vi) Slip gauge.
2. Measurement of angle of a component using :
 - (i) Vernier bevel protractor, (ii) angle gauges , (iii) Sine-bar and slip gauges.
3. Checking / measuring parallelism, cylindricity and concentricity of components using dial indicator.
4. Measurement of a specific dimension for a lot of components, and prepare a histogram from the dataobtained.
5. Measurement of surface finish by a Talysurf instrument.
6. Measurement of micro feature of a product (eg. Thread of a bolt or saw etc.) in a profile projector.
7. Determine natural cooling characteristics of a heated object by using a thermocouple.
8. Measurement of air velocity across an air duct using anemometer.
9. Fixing a strain gauge on a cantilevered flat section of steel. Then calibration of it as a forcedynamometer using a Wheatstone bridge and loading arrangement.

CO – PO/PSO Mapping:

COs	PO 1	PO 2	PO 3	PO 4	PO 5	PO 6	PO 7	PO 8	PO 9	PO 10	PO 11	PO 12	PSO 1	PSO 2	PSO 3
CO1	1	2	-	2	1	-	2	2	-	2	-	-	2	-	3
CO2	2	1	2	-	-	1	2	1	1	1	-	-	-	3	-
CO3	3	2	-	2	1	-	2	2	-	1	-	-	3	-	-
CO4	3	-	2	-	-	2	-	3	-	2	-	-	-	2	-

COURS NAME: MECHATRONICS SYSTEM LAB

COURSE CODE: EC(ME)591A

CONTACTS: 0:0:2

CREDITS: 1

Prerequisite: Fluid Mechanics, Basic Electronics, Mechatronics Theory.

Course Outcomes:

CO1: Describe and demonstrate Mechatronics systems and overview of control systems & actuators.

CO2: Distinguish between various sensors, transducers and actuators and their applications.

CO3: Understand the basic concept of microprocessor and perform simple operations on it.

CO4: Identify various signal conditioning units, amplifiers, logic gates and their role in programmable logic controllers

List of Experiments

1. Open loop position control;
2. Closed loop position control using positional and velocity feedback;
3. Use of analog and digital servosystems,
4. Use of PID control;
5. Experiments on pneumatic drives and actuators;
6. Experiments on hydraulic drives and actuators;
7. Use of logic gates;
8. Programming on a 8085 Microprocessor training kit.
9. Programming on a PLC for simple control operations.

CO- PO/PSO Mapping

CO Codes	PO 1	PO 2	PO 3	PO 4	PO 5	PO 6	PO 7	PO 8	PO 9	PO 10	PO 11	PO 12	PSO 1	PSO 2	PSO 3
CO1	1	-	2	-	1	-	-	-	2	1	2	-	-	-	-
CO2	1	-	2	-	1	-	-	-	-	1	3	1	2	-	1
CO3	1	-	2	-	2	-	-	-	-	1	2	-	-	-	-
CO4	2	-	3	-	1	-	-	-	-	1	3	-	1	-	1

COURSE NAME: FLUID POWER CONTROL LAB

COURSE CODE: EE(ME)591B

CONTACTS: 0: 0: 2

CREDITS: 1

Prerequisite: Fluid Power Control.

Course Outcomes:

CO1: Demonstrate the devices such as pumps, compressor, valves, actuators and sensors etc.

CO2: Differentiate hydraulic and pneumatic circuits.

CO3: Apply fluid control valves in different industrial application.

CO4: Design and evaluate fluid powered control circuits and express through proper drawing.

List of Experiments:

Experiment No.	Description
1	Study of Basic hydraulic circuits for the working of single and double acting cylinder, hydraulic pump and hydraulic motor.
2	To Study of Basic pneumatic circuits for the working of single and double acting cylinder, Compressor.
3	To Study of control valve (PCV, DCV, FCV) in a circuit for the working of single and double acting cylinder in a hydraulic and pneumatic system.
4	To Studies of Circuits for the Use of different direction control valves and valve actuation in single and double acting cylinder, and multi actuation circuit.
5	To Study and perform of Speed control circuits. Different Metering methods Inlet & outlet flow control (meter-in& meter-out circuit).
6	To Study Hydraulic or Pneumatic Sequencing circuit with magnetic sensor with Clamp, Direction Control Valves (Manual/External/Solenoid Operated), Flow Control Valves, Roller Lever Valve, Rapid Release Valve.
7	To perform AND & OR logic gate for a double acting cylinder using two cylinders by manual control.
8	To operate Two double acting cylinders, (Sequence of operation A+B+A-B-) using manual control & electrohydraulic control.
9	Study of circuit with cam operated pilot valves operating a pilot operated 4way direction control Valve or proximity/ limit switches, solenoid operated 4way direction control valve for Auto reversing circuit.

CO – PO/PSO Mapping:

CO Codes	PO 1	PO 2	PO 3	PO 4	PO 5	PO 6	PO 7	PO 8	PO 9	PO 10	PO 11	PO 12	PSO 1	PSO 2	PSO 3
CO1	3	1	2	-	2	-	-	-	-	-	-	-	1	1	2
CO2	2	-	1	-	1	-	-	1	-	1	2	1	2	1	1
CO3	2	1	3	-	1	1	-	-	-	-	1	1	3	2	2
CO4	2	1	2	-	1	-	-	1	-	-	2	3	2	1	2

COURSE NAME: DATABASE MANAGEMENT SYSTEM LAB

COURSE CODE: CS(ME)591C

CONTACT: 0:0:2

CREDITS: 1

Prerequisite:

1. Logic of programming language
2. Basic concepts of data structure and algorithms

Course Outcome(s): On completion of the course students will be able to
CO1: Understand the database management system and database language

CO2: Understand and apply the SQL queries related to management of data and transaction processing.

CO3: Explain about query processing techniques involved in query optimization

CO4: Understand PL/SQL programming, the concept of Cursor Management, Error Handling, Package and Triggers

CO5: Design and build the commercial database systems.

Course Contents:

Module 1 Conceptual Designing using ER Diagrams (Identifying entities, attributes, keys and relationships between entities, cardinalities, generalization, specialization etc.)

Module 2 Converting ER Model to Relational Model (Represent entities and relationships in Tabular form, Represent attributes as columns, identifying keys) and apply the normalization techniques.

Module 3 Creation of Tables using SQL- Overview of using SQL tool, Data types in SQL, Creating Tables

(along with Primary and Foreign keys), Altering Tables and Dropping Tables

Module 4 Practicing DML commands- Insert, Select, Update, Delete

Module 5 Practicing Queries using ANY, ALL, IN, EXISTS, NOT EXISTS, UNION, INTERSECT, CONSTRAINTS etc., Practicing Sub queries (Nested, Correlated) and Joins (Inner, Outer and Equi).

Module 6 Practice Queries using COUNT, SUM, AVG, MAX, MIN, GROUP BY, HAVING, VIEWS Creation and Dropping, Practicing on Triggers - creation of trigger, Insertion using trigger, Deletion using trigger, Updating using trigger

Module 7 Procedures- Creation of Stored Procedures, Execution of Procedure, and Modification of Procedure, PL/SQL, Cursors- Declaring Cursor, Opening Cursor, Fetching the data, closing the cursor.

CO- PO/PSO Mapping

CO Codes	PO 1	PO 2	PO 3	PO 4	PO 5	PO 6	PO 7	PO 8	PO 9	PO 10	PO 11	PO 12	PSO 1	PSO 2	PSO 3
CO1	3	3	3	3	1	2	-	-	2	1	2	-	-	-	-
CO2	3	3	3	3	1	1	-	-	-	1	3	1	2	-	1
CO3	3	3	2	2	2	2	-	-	-	1	2	-	-	-	-
CO4	3	3	3	3	1	1	-	-	-	1	3	-	1	-	1
CO5	3	3	3	3	3	2	1	1	1						

COURSE NAME: SOFT SKILL -I

COURSE CODE: HU(ME)591

CONTACT: 0:0:1

CREDITS: 0.5

Pre-requisites: Basic (10+2) level of knowledge of English grammar, vocabulary reading and writing skills.

Course Content:

Module- 1: Verbal and Non-verbal communication **4L**

- 1.1: Definition, Relevance and Effective Usage
- 1.2: Components of Verbal Communication: Written and Oral Communication
- 1.3 :Components of Non-verbal Communication: Kinesics, Proxemics, Chronemics, HapticsParalanguage
- 1.4: Barriers to Effective Communication

Module- 2: Social Communication Essentials and Cross-Cultural Communication **6L**

- 2.1: Communication in Society and the Workplace
- 2.2: Greetings, Courtesies and Socially Useful Language
- 2.3: Cultural Contexts: High Context and Low Context Cultures 2.4: Understanding Cultural Nuances and Stereotyping
- 2.5: Achieving Culturally Neutral Communication in Speech and Writing

Module- 3: Meetings **4L**

- 3.1: Meetings: Nature and Types
- 3.2: Conducting Meetings: Organization and Procedures
- 3.3: Meeting Coordination: Roles of Chairpersons and Members3.4: Notice and Agenda for a Meeting
- 3.5: Preparing the Minutes of a Meeting (MOM)

Module- 4: Report Writing **4L**

- 4.1: Nature and Function of Reports4.2: Types of Reports
- 4.3: Researching for a Business Report4.4: Format, Language and Style
- 4.5: Report Documentation

Module 5: Employment Communication **10L**

- 5.1: Writing Business Letters- (Enquiry, Order, Sales, Complaint, Adjustment, Job Application, Offer)
- 5.2: Preparing a CV or Résumé
- 5.3: Creating a Digital/Online Profile – LinkedIn (Résumé/Video Profile) 5.4: Writing E-mails: types, convention, and etiquette
- 5.5: Memo, Notices and Circulars
- 5.6: Writing Technicalities—Paragraphing, Sentence Structure and Punctuation

Text Books &Reference Books:

1. Meenakshi Raman and Sangeetha Sharma. *Technical Communication*. 3rd edition. NewDelhi: Oxford University Press, 2015.
2. Mark Ibbotson. *Cambridge English for Engineering*. Cambridge: Cambridge University Press, 2008.

Reference Book

1. Mark Ibbotson. Professional English in Use: Engineering. Cambridge: Cambridge UP,2009.
2. Lesikar et al. Business Communication: Connecting in a Digital World. New Delhi: TataMcGraw-Hill, 2014.
3. John Seeley. Writing Reports. Oxford: Oxford University Press, 2002.
4. Judith Leigh. CVs and JobApplications. Oxford: Oxford University Press, 2002.
5. Judith Leigh. Organizing and Participating in Meetings. Oxford: Oxford University Press,2002.
6. Michael Swan. Practical English Usage. Oxford: OUP, 1980.
7. Pickett, Laster and Staples. Technical English: Writing, Reading & Speaking. 8th ed.London: Longman, 2001.
8. Diana Booher. E-writing: 21st Century Tools for Effective Communication.

Links:

1. Purdue University's Online Writing Lab (OWL)-<https://owl.purdue.edu/>
2. Business English Pod-<https://www.businessenglishpod.com/>

COURSE NAME: MODELING & SIMULATION OF MECHANICAL SYSTEMS

COURSE CODE: ME594

CONTACT HOUR: 0:0:1

CREDITS: 0.5

Prerequisite: Engineering Drawing, Mathematics

Course Contents:

Module	Syllabus	Contact Hrs.
--------	----------	--------------

Module 1 Introduction	Introduction to CAE, CAD. Role of CAD in Mechanical Engineering, Design process, software tools for CAD,geometric modelling.	2
Module 2 Transformations in Geometric Modeling	Introduction, Translation, Scaling, Reflection, Rotation in 2D and 3D. Homogeneous representation of transformation, Concatenation of transformations. Computer-Aided assembly of rigid bodies, applications of transformations in design and analysis of mechanisms, etc.	4
Module 7 Solids in Geometric Modeling for Design	Solid entities, Boolean operations, Topological aspects, Invariants. Write-frame modeling, B-rep of Solid Modelling, CSG approach of solid modelling. Popular modeling methods in CAD softwares. Data Exchange Formats and CAD Applications:	6

TEXT BOOK:

1. Michael E. Mortenson, Geometric Modelling, Tata McGraw Hill, 2013.
2. A. Saxena and B. Sahay, Computer-Aided Engineering Design, Anamaya Publishers, NewDelhi, 2005.

Reference Book

1. Rogers, David F., An introduction to NURBS: with historical perspective, Morgan KaufmannPublishers, USA, 2001.
2. David F. Rogers, J. A. Adams, Mathematical Elements for Computer Graphics, TMH, 2008.

COURSE NAME: Minor Project I

COURSE CODE: ME581

CONTACT HOUR: 0:0:2

CREDITS: 1

Prerequisite: Fundamentals of Mechanical Engineering.

Course Contents:

- i) literature review on topic of interest.
- ii) Finding research Gaps
- iii) Attempt to solve problems towards filling the research gaps.

3rd Year 2nd Semester

Sl. No.	Category	Course Code	Course Title	Hours per week				Credits
				L	T	P	Total	
THEORY								
1	Major	ME601	IC Engine & Hybrid Vehicles	3	0	0	3	3
2	Major	ME602	Design of Machine Elements	3	0	0	3	3
3	Major	ME603	A. Power Plant	3	0	0	3	3

			Engineering B. Computational Fluid Dynamics C. Tribology					
4	Minor	EC(ME)601A	Robotics	3	1	0	4	4
		EE(ME)601B	Electrical Machines					
		CS(ME)601C	Artificial Intelligence & Machine Learning					
PRACTICAL								
1	Major	ME691	Thermal Engineering Lab	0	0	3	3	1.5
2	Major	ME692	Design Lab	0	0	3	3	1.5
3	Minor	EC(ME)691A	Robotics Lab	0	0	0	2	1
		EE(ME)691B	Electrical Machines Lab					
		CS(ME)691C	Artificial Intelligence & Machine Learning Lab					
4	Ability Enhancement Course	HU(ME)691	Soft Skill-II	1	0	0	1	0.5
5	Internship	ME681	Industrial Training (Min. 2 weeks)	0	0	0	0	1
6	Project	ME682	Minor Project II	0	0	2	2	1
TOTAL CREDIT								19.5

*‘Mandatory Additional Requirement’ (MAR) activities have to be carried out as per university guidelines.

COURSENAME: INTERNAL COMBUSTION ENGINE AND HYBRID VEHICLES

COURSE CODE: ME601

CONTACT: 3:0:0

TOTAL CONTACTHOURS: 36

CREDITS:3

Prerequisite: Applied Thermodynamics, Fluid mechanics.

Course Outcomes:

CO1: Get the knowledge of engine nomenclature, performance parameters and characteristics of

- different fuels to differentiate several types of I C engine designs.
- CO2: Understand several losses in an engine Understand several losses in an engine to predict performance and fuel economy trends with good accuracy.
- CO3: Identify modern injection systems, cooling & lubrication systems and supercharging to optimize the thermal efficiency and emission standards.
- CO4: Explore new generation hybrid engines and basics of electric vehicles to acquire modern industry standards.

Course Contents:

Module No.	Syllabus	Contact Hrs.
1 Engine Fundamentals	Classification and working of basic engine types: 2-stroke & 4-stroke Engines, SI & CI Engines, Engine Nomenclature, Performance parameters; Measurement of speed, torque, fuel consumption, IHP, BHP and FHP, SFC, thermal efficiency,	5
2 Fuel Air Cycle & Actual Cycle	Review of Air Standard Cycles, Fuel-Air cycles: Assumptions, Effect of specific heat & Dissociation, Performance analysis of fuel air cycle. Actual cycles: Assumptions, Heat Loss, Time loss and Blowdown loss, Optimum spark advance	6
3 Fuels & Combustion	Fuels: classification and desirable characteristics, HCV and LCV, Rating of fuels, Alternative fuels. Combustion of fuels in S.I and C.I engines, Parameters influencing combustion, Detonation and knocking in S.I. and C.I. engines and their preventions, Types of combustion chambers, Analysis of combustion product	7
4 Fuel Mixing, Injection and Ignition Systems	Fuel-Air mixing in SI Engines, Analysis of a simple carburetor, Disadvantages. Fuel injection systems: Working principle, Injection pumps and nozzles, electronic fuel injection system, MPFI systems, Ignition systems: ignition timing and spark advance, firing order.	8
5 Engine Cooling, Scavenging & Supercharging	Cooling and Lubrication: Properties of lubricating oil, Air and liquid cooling. Scavenging: ideal and actual, scavenging pumps, Supercharging and Turbo charging	5
6 Electric vehicles and Hybrid Engines	History, Components and General Layout of Electric vehicle (EV), EV classification, Comparison with IC Engine, Advantages and disadvantages of EV, Components and General Layout of Hybrid EV, Comparison with EV, Advantages and disadvantages of Hybrid EV.	5
Total Hours (36L)		

Text Books:

1. V. Ganesan, Internal Combustion Engines, The McGraw-Hill Companies.
2. M.L. Mathur and R.P. Sharma, A course in Internal Combustion Engines, Dhanpat Rai & Sons.
3. H.N. Gupta, Fundamentals of Internal Combustion Engines, PHI Learning Private Ltd.
4. Electric vehicle technology explained, James Larminie and John Lowry, Wiley.
5. Introduction to Hybrid vehicle system Modeling and control, Wei Liu, Wiley.

ReferenceBooks:

6. S.K. Som, Introduction to Heat Transfer, PHI.
7. Kreith, Principles of Heat Transfer, Cengage learning.
8. O.P. Single, Heat & Mass Transfer, Macmillan India.

CO – PO/PSO Mapping:

COs	PO 1	PO 2	PO 3	PO 4	PO 5	PO 6	PO 7	PO 8	PO 9	PO 10	PO 11	PO 12	PSO 1	PSO 2	PSO 3
CO1	3	2	2	2	-	1	1	-	-	1	2	2	2	3	2
CO2	2	1	3	2	-	2	2	1	-	1	2	2	2	2	2
CO3	3	3	3	3	2	1	1	-	-	1	3	3	2	2	2
CO4	2	1	2	2	3	3	3	1	-	1	2	3	2	3	2

COURSE NAME: DESIGN OF MACHINE ELEMENTS**COURSE CODE: ME 602****CONTACT: 3:0:0****TOTAL CONTACT****HOURS: 36****CREDITS: 3****Prerequisite:** Rigid body Mechanics, Strength of Materials, Theory of Machine.**Course Outcomes:**

CO1: Understand the use of codes, standards for designing.

CO1: Able to prevent failure under static and fluctuating load.

CO3: Able to analyze the different kind of stresses, which generates due to the loading in different mechanical element.

CO2: Able to design different mechanical elements.

Course Content

Module No.	Syllabus	Contact Hrs.
1.Fundamentals of design of machine elements	Theory of failures to prevent static failure; Design consideration under cyclic stresses; S-N Curve; Endurance limit; Design for Infinite cycle and finite cycles under cyclic loading; Uses of Stress concentration factor(k_t); Notch sensitivity; Theoretical stress concentration factor; Gerber line, Soderberg line, Goodman Line, Modified Goodman Line.	7
2.Design of Shaft and Bearings	Design of shafts under static and fatigue loadings, Design of shaft using ASME code, Analysis and design of sliding and rolling contact bearings	6
3. Design of transmission elements	Spur, helical, bevel and worm gears; static & dynamic load calculation, belt and chain drives	7
4. Design of springs	Helical compression, tension, torsional and leaf springs	4
5. Design of joints	Threaded fasteners, pre-loaded bolts and welded joints, joint efficiencies, Analysis and applications of power screws and couplings	6
6. Design of Clutch and Brakes	Analysis of clutches and brakes	6
Total Lectures: 36L		

Text Books:

1. V. B. Bhandari, Design of Machine Elements, TMH.
2. Shigley, J.E. and Mischke, C.R., Mechanical Engineering Design, Fifth Edition, McGraw-Hill International; 1989.

Reference Book

3. Deutschman, D., Michels, W.J. and Wilson, C.E., Machine Design Theory and Practice, Macmillan, 1992

CO – PO/PSO Mapping:

COs	PO 1	PO 2	PO 3	PO 4	PO 5	PO 6	PO 7	PO 8	PO 9	PO 10	PO 11	PO 12	PSO 1	PSO 2	PSO 3
CO1	2	-	2	-	1	-	-	-	1	1	1	1	3	3	2
CO2	2	3	3	2	-	-	-	-	-	-	-	-	2	2	2
CO3	1	3	3	3	-	-	1	-	-	-	-	-	2	3	2
CO4	2	3	3	3	2	1	-	1	-	1	2	2	2	2	2

COURSE NAME: POWER PLANT ENGINEERING
COURSE CODE: ME 603A

CONTACT: 3:0:0

TOTAL CONTACT HOURS: 36

CREDITS:3

Prerequisite: Applied Thermodynamics

Course Outcomes:

CO1: Explore minute details of all components of coal-based power plant including steam generation, fuel and ash handling equipment.

CO2: Understand the principle of steam and gas-based turbines to analyze their performance for a variety of design conditions.

CO3: Describe brief functionalities of Nuclear, Hydel and other renewable energy-based power plants.

CO4: Evaluate plant performance with the knowledge of plant economics.

Course Contents:

Module	Syllabus	Contact Hrs
1 Thermal Power Plant	Coal based thermal power plants, Coal properties, Combustion analysis, layout of modern coal power plant, super critical boilers, FBC boilers, turbines, condensers & Cooling Towers, Steam and heating rates, subsystems of thermal power plants, fuel and ash handling, draught system, feed water treatment, Losses in boilers, boilers efficiency binary cycles and cogeneration systems.	10
2 Steam Turbine & Condensing Systems	Steam turbine- Major classification, Nozzles types and efficiency, Impulse turbine - velocity diagram, work done and blade efficiency. Pressure compounding and velocity compounding of steam turbine. Impulse reaction turbine - Velocity diagram, degree of reaction and Parsons turbine. Governing in Steam turbine. Condenser and Cooling Towers	8
4 Gas Turbineand Combined Cycle	Diesel Power Plant, Gas turbine and combined cycle power plants, components of gas turbine power plants, combined cycle power plants, Brayton Cycle – Analysis & Optimization. Integrated Gasifierbased Combined Cycle (IGCC) systems.	5
5 Nuclear Power Plants	Basics of nuclear energy conversion, Layout and subsystems of nuclear power plants, Boiling Water Reactor, Pressurized Water Reactor, CANDU Pressurized Heavy Water Reactor, Fast Breeder Reactors, Gas cooled and liquid metal cooled reactors, safety measures for nuclear power plants.	5
6 Hydel and Renewable Energy plants	Hydroelectric power plants, classification, typical layout and components, principles of wind, tidal, solar PV and solar thermal, geothermal, biogas and fuel cell power systems.	4

7 Plant Economics	Energy, economic and environmental issues, power tariffs, load distribution parameters, load curve, capital and operating cost of different power plants, pollution control technologies including wastedisposal options for coal and nuclear plants	4
TOTAL		36L

Text Books:

1. P.K. Nag, -Power plant Engineering,|| Tata McGraw Hill.
2. Arora and Domkundwar, —A course in Power Plant Engineering| Dhanpat Rai & Sons.

Reference Book:

3. M. M. EI- Wakil, -Power plant technology,|| Tata McGraw - Hill.

CO– PO/PSO Mapping:

CO	PO 1	PO 2	PO 3	PO 4	PO 5	PO 6	PO 7	PO 8	PO 9	PO 10	PO 11	PO 12	PSO 1	PSO 2	PSO 3
CO1	3	3	2	1	2	3	2	1	-	-	3	2	2	2	3
CO2	2	2	3	1	3	1	2	1	1	1	2	3	3	2	2
CO3	2	1	2	1	3	1	2	1	-	1	1	2	2	2	2
CO4	3	3	3	2	2	1	1	2	1	1	2	3	3	2	3

COURSE NAME: COMPUTATIONAL FLUID DYNAMICS

COURSE CODE: ME603B

CONTACT: 3:0:0

TOTAL CONTACT HOURS: 36

CREDITS: 3

Prerequisite: Fluid mechanics, Thermodynamics, Heat Transfer

Course Outcomes:

- CO1. Create numerical modeling and its role in the field of fluid flow
- CO2. Use the various discretization methods, solution procedures and
- CO3. Solve turbulence modeling flow and heat transfer problems.

Course Contents:

Module No.	Syllabus	Contact Hrs.
1. Introduction	Basics of computational fluid dynamics – Governing equations of fluid dynamics – Continuity, Momentum and Energy equations – Chemical species transport – Physical boundary conditions – Time-averaged equations for Turbulent Flow – Turbulent–Kinetic Energy Equations – Mathematical behavior of PDEs on CFD - Elliptic, Parabolic and Hyperbolic equations.	7
6. Finite difference and finite volume methods for diffusion	Derivation of finite difference equations – Simple Methods – General Methods for first and second order accuracy – Finite volume formulation for steady state One, Two and Three - dimensional diffusion problems –Parabolic equations – Explicit and Implicit schemes – Example problems on elliptic and parabolic equations – Use of Finite Difference and Finite Volume methods.	6
3. Finite volume method for convection diffusion	Steady one-dimensional convection and diffusion – Central, upwind differencing schemes properties of discretization schemes – Conservativeness,	6
4. Flow field analysis	Finite volume methods -Representation of the pressure gradient term and continuity equation – Staggered grid – Momentum equations – Pressure and Velocity corrections	5
5. Turbulence models and mesh generation	Important features of turbulent flow, Vorticity transport equation, Statistical representation of turbulent flows: Homogeneous turbulence and isotropic turbulence, General Properties of turbulent quantities, Turbulence models, mixing length model, Two equation (k- ϵ) models – High and low Reynolds number models	6
Total Hours		36 L

TEXT BOOKS:

1. Prodip Niyogi, Chakrabarty, S.K., Laha, M.K. "Introduction to Computational Fluid Dynamics", Pearson Education, 2005.
2. Versteeg, H.K., and Malalasekera, W., "An Introduction to Computational Fluid Dynamics: The finite volume Method", Pearson Education Ltd. Second Edition – 2007.

REFERENCES:

1. Anil W. Date, "Introduction to Computational Fluid Dynamics", Cambridge University Press, 2005.
2. Patankar, S.V. "Numerical Heat Transfer and Fluid Flow",

Hemisphere Publishing Corporation, 2004.

3. Chung, T.J., "Computational Fluid Dynamics", Cambridge University, Press, 2002.
4. Ghoshdastidar P.S., "Heat Transfer", Oxford University Press, 2005
5. Muralidhar, K., and Sundararajan, T., "Computational Fluid Flow and Heat Transfer", Narosa Publishing House, New Delhi, 1995.
6. S.V.Patankar, Numerical Heat Transfer and Fluid Flow, McGraw-Hill.
7. T. J. Chung, Computational Fluid Dynamics, Cambridge University Press.
8. John D.Anderson Jr, Computational Fluid Dynamics, McGraw Hill Book Company.

CO – PO/PSO Mapping:

COs	PO 1	PO 2	PO 3	PO 4	PO 5	PO 6	PO 7	PO 8	PO 9	PO 10	PO 11	PO 12	PSO 1	PSO 2	PSO 3
CO1	3	2	2	2	1	-	-	1	2	1	1	2	2	1	2
CO2	3	2	3	1	1	-	1	2	-	1	-	3	2	2	3
CO3	3	3	3	3	1	1	-	1	-	1	-	2	2	1	2
CO4	3	2	2	2	1	-	-	1	2	1	1	3	2	2	3

COURSE NAME: TRIBOLOGY

COURSE CODE: ME 703C

CONTACT: 3:0:0

CONTACT HOURS: 36

CREDIT: 3

Prerequisites: Machine Design

Course Outcomes: On successful completion of the course, the learner will be able to

CO1: Become familiar with mathematical tools used to analyze Tribological processes.

CO2: Have awareness of Tribological issues in the design of machine components, such as rolling element bearings, journal bearings, thrust bearings, seals, and braking systems.

CO3: Become familiar with common anti-friction and anti-wear components.

CO4: Design a Tribological system for optimal performance.

Course Contents:

Module No.	Syllabus	Contact Hrs.
1.	Introduction: History, Industrial Importance. Engineering Surfaces: Properties and Measurement: Measurement Methods, Surface Profilometry, Statistical Description of Roughness.	4
2.	Surface Contact: Hertz contact theory, Greenwood-Williamson model, Elastic-plastic contact. Adhesion: Basic Models, Factors influencing Adhesion.	5
3.	Friction: Measurement Methods, Origin of Friction, Friction Theories – adhesion and ploughing, Mechanisms, Friction of Metals, Non-metallic Materials.	4
5.	Surface Engineering: Surface Treatments: Microstructural and Thermochemical Treatments, Surface Coatings: Hard Facing, Vapour Deposition Processes: PVD, CVD, PECVD etc.	5
6.	Lubrication: Basic Equations for Fluid Film Lubrication. Hydrodynamic lubrication -Thrust and Journal bearings, Squeeze Film Bearings, Hydrostatic lubrication, Gas-Lubrication. Lubrication of rolling element bearings. Boundary lubrication – metal working lubrication, solid film lubrication. Hygiene of lubricants.	8
7.	Nanotribology: Measurement Tools: Surface Force Apparatus, Scanning Tunneling Microscope, Atomic / Friction Force Microscope.	4

Text Books:

1. P. Sahoo, Engineering Tribology, Prentice Hall-India, New Delhi, 2009.
2. B. Bhushan, Introduction to Tribology, Wiley, 2002.
3. G W Stachowiak and A W Batchelor, Engineering Tribology, Butterworth-Heinemann,2005.
4. S.K. Basu, S.N. Sengupta, B.B. Ahuja, Fundamentals of Tribology, Prentice Hall-India, 2005.
5. B C Majumdar, Introduction to Tribology of Bearings, S Chand & Co, 2012.

CO – PO/PSO Mapping:

CO	PO 1	PO 2	PO 3	PO 4	PO 5	PO 6	PO 7	PO 8	PO 9	PO 10	PO 11	PO 12	PSO 1	PSO 2	PSO 3
CO1	3	2	2	1	-	-	-	-	-	1	-	1	-	2	-
CO2	2	1	1	1	-	-	-	-	-	1	-	2	3	-	-
CO3	3	2	1	2	-	-	-	-	-	1	-	1	-	2	-
CO4	2	1	2	1	-	-	-	-	-	1	-	2	-	2	3

COURSE NAME: ROBOTICS
COURSE CODE: EC(ME)601A
CONTACT: 3:0:0
TOTAL CONTACT HOURS: 36
CREDITS: 3

Prerequisite: Basic Electronics, mechanism, manufacturing technology.

Course Outcomes: Upon successful completion of this course, students will be able to

CO1: Understand the various robot structures and their workspace.

CO2: Learn about robot kinematics.

CO3: Analyze the different control drives in robot operation system.

CO4: Apply programming for controlling the robotic operation.

Course Contents:

Module No.	Syllabus	Contact Hrs.
1	Introduction: Brief history of robotics; definition of robot; Main components of robot: manipulator, sensors, controller, power conversion unit; Robot geometry: types of joints, workspace, number of degrees of freedom; Common configurations used in arms: rectangular, cylindrical, spherical, joined; Classification of robot according to coordinate system: cartesian, cylindrical, polar, articulated or jointed; Classification of robots according to control method: non-servo, servo; Robot specifications: payload, accuracy, repeatability resolution, maximum tip speed, reach stroke:	7
2	Robot kinematics: Definition of Robot kinematics, Tool frame and base frame. Forward kinematics, Inverse kinematics, Describing position and orientation of an object in space, Homogenous transformation, Translational transformations, Rotational transformations, Denavit-Hartenberg representation.	6
3	End effectors: End effectors- classification- mechanical, magnetic, vacuum and adhesive gripper- gripper force analysis and design. Robot control- Unit control system concept- servo and non-servo control of robot joints, adaptive and optimal control.	5
4	Robot actuators: Definition; Characteristics: power to weight ratio, stiffness, compliance, reduction gears; Conventional actuators: hydraulic actuator, pneumatic actuator, electric motor, direct drive motor, stepper motor, servo motor; Special actuators: magnetostrictive, shape memory alloy, elastomer.	4
5	Robot Sensors: Sensor devices, Types of sensors- contact, position and displacement sensors, Force and torque sensors- Proximity and range sensors- acoustic sensors- Robot vision systems- Sensing and digitizing-Image processing and analysis.	5
6	Robot Programming: Robot language classification- programming methods- off and online programming- Lead through method-Teach pendent method- VAL systems and language, simple program.	4

7	Industrial Application: Application of robots- Material handling- Machine loading and unloading, Assembly, Inspection, Welding, Spray painting, Mobile robot, Microbots- Recent developments in robotics- safety consideration.	5
----------	--	----------

Text Books:

1. S.R. Deb, Robotics Technology and Flexible Automation, Tata McGraw-Hill Publication, New Delhi, 1994.
2. M.P. Groover. Industrial Robotics Technology Programming and Applications, McGrawHill Book Co, Singapore, 1987.

Reference Books:

3. S. K. Saha, Introduction to Robotics, McGraw-Hill Publication, 2014.
4. Y. Koren, Yoram, Robotics for Engineers, McGraw-Hill Book Company, Singapore.
5. W. Stadler, Analytical Robotics and Mechatronics, McGraw Hill Book Co., 1995.

CO – PO/PSO Mapping:

COs	PO 1	PO 2	PO 3	PO 4	PO 5	PO 6	PO 7	PO 8	PO 9	PO 10	PO 11	PO 12	PSO 1	PSO 2	PSO 3
CO1	3	2	2	1	-	-	-	-	1	1	-	2	2	1	2
CO2	2	1	1	2	1	-	-	1	-	1	2	3	2	2	3
CO3	2	2	2	1	1	1	-	-	-	-	1	3	2	1	2
CO4	2	1	2	2	1	1	-	1	-	-	2	3	2	2	3

COURSE NAME: ELECTRICAL MACHINE

COURSE CODE: EE(ME)601C

COURSE CREDIT: 3:0:0

CONTACT HOURS: 36 LCREDIT: 3

Prerequisite: Basic electrical engineering

Course Outcome

CO1: Formulate and then analyze the working of any electrical machine under loaded and unloaded conditions.

CO2: Understand and explain the principle of operation and performance of DC machine, Three Phase Induction Motor, Synchronous Machine and Fractional kW Motors.

CO3: Analyze the response of DC machine, Three Phase Induction Motor, Synchronous Machine and Fractional kW Motors.

CO4: Troubleshoot the operation of DC machine, Three Phase Induction Motor, Synchronous Machine and Fractional kW Motors.

CO5: Analyze given require specification of electrical machine and select a suitable measuring instrument for a given application.

Course Content

Module No.	Syllabus	Contact Hrs
1 DC Machines	EMF generated in the armature, OCC and Voltage build-up in d.c. generator - concept of critical resistance & critical speed. External Characteristics. Armature reaction - function of Interpoles & Compensating windings. Commutation process, Concept of back e.m.f. - Speed & Torque equation of d.c. motor, Speed control of DC motor, Losses and Efficiency, Application of d.c. Machine	9
2 3-Phase Induction machine	Construction of 3-phase induction motor. Production of rotating magnetic field (concept only) - Working principle of 3-phase induction motor. Concept of synchronous speed & slip. Phasor diagram (at no-load & running condition). Equivalent circuit - No-load and Blocked rotor test. Torque equation. Torque-slip characteristic. Power flow in 3-phase induction motor (Numerical). Speed control & Braking of Induction motor. Starting methods of 3-phase induction motor – DOL, Auto-transformer & Star-Delta starter. Industrial application of 3-phase Induction motor	10
3 Synchronous Machines	Construction & Types of synchronous machines. Method of excitation system. Working principle of synchronous machines - generator & motor modes. Armature reaction at different power factor - concept of synchronous reactance.	10

	Theory of salient pole machine, Two reaction theory Voltage regulation by synchronous impedance method (with Numerical). Synchronous machine connected to infinite bus, Synchronization of two or more alternators and an alternator with infinite bus. Load sharing between them. Principle of operation of synchronous motor- its starting techniques - Damper winding & Hunting. V_c Curves – Synchronous condenser.	
4 Fractional Kilowatt motors	Single phase Induction motor: Construction, Double revolving field theory. Starting methods, Speed - torque characteristics & Application Principle of operation & Application of Stepper motors Principle of operation of Welding Transformer	7
	Total	36L

Text Books:

1. P.S. Bhimra, Electrical Machinery, Khanna Publishers.
2. D.P. Kothari & I.J Nagrath, Electric machines, Tata Mc Graw-Hill Publishing Company Limited.

Reference Books:

1. Bhag S. Guru and H.R. Hiziroglu, Electric Machinery & Transformers, Oxford University press.
2. R.K. Srivastava, Electrical Machines, Cengage Learning.
3. Alexander S Langsdorf, Theory of Alternating Current Machinery, Tata Mc Graw Hill.
4. M.G. Say, The performance and Design of Alternating Current Machines, CBS Publishers & Distributors.
5. Irving L Koskow, Electric Machinery & transformer, Prentice Hall India.

CO-PO/PSO Mapping:

COs	PO 1	PO 2	PO 3	PO 4	PO 5	PO 6	PO 7	PO 8	PO 9	PO 10	PO 11	PO 12	PSO 1	PSO 2	PSO 3
CO1	2	-	1	1	-	-	-	-	-	1	-	-	1	1	2
CO2	2	2	2	2	-	-	-	-	-	1	-	1	2	1	1
CO3	2	2	1	2	-	-	-	-	-	1	-	1	3	2	2
CO4	2	-	1	1	-	-	-	-	-	-	-	1	3	2	1
CO5	2	2	1	2	-	-	-	-	-	1	-	1	3	2	2

COURSE NAME: ARTIFICIAL INTELLIGENCE & MACHINE LEARNING

COURSE CODE: CS(ME)601C

CONTACT HOURS: 36L

CREDIT: 3

Prerequisite: Probability, Matrix operations, Basic programming

Course Outcomes: Upon successful completion of this course, students will be able to achieve:

CO1: Learn Advanced Data Analysis skills

CO2: Create AI/ML solutions for various business problems.

CO3: Build and deploy production grade AI/ML applications.

CO4: Apply AI/ML methods, techniques and tools immediate.

Course Contents:

Module No.	Syllabus	Contact Hrs.
1.	Introduction to Data Science and AI & ML, Essentials (Tutorial) Programming, Statistical Analysis Initial Data Analysis	6
2.	Data Acquisition, Data Pre-processing and Preparation, Data Quality and Transformation, Handling Text Data, Principles of Big Data	6
3.	Data Visualization, Sampling and Estimation, Inferential Statistics, LinearRegression, Multiple Linear Regression, Non-Linear Regression	6
4.	AI: Application areas; AI Basics (Divide and Conquer, Greedy, Branch and Bound, Gradient Descent); NN basics (Perceptron and MLP, FFN, Back propagation) Convolution Neural Networks: Image classification; Text classification; Image classification and hyper-parameter tuning; Emerging NN architectures	6
5.	Recurrent Neural Networks: Building recurrent NN; Long Short-Term Memory; Time Series Forecasting;	6
6.	Deep Learning: Auto-encoders and unsupervised learning; Stacked auto-encoders and semi-supervised learning; Regularization - Dropout andBatch normalization	6
Total 36 L		

Text Books:

1) Artificial Intelligence A Modern Approach Stuart J. Russell and Peter Norvig.

2)ARTIFICIAL INTELLIGENCE, Third Edition, E. Rich, K. Knight, SB Nair, Tata Mc Grawhill

CO-PO/PSO Mapping

CO	PO 1	PO 2	PO 3	PO 4	PO 5	PO 6	PO 7	PO 8	PO 9	PO 10	PO 11	PO 12	PSO 1	PSO 2	PSO 3
CO1	1	-	1	-	-	3	1	-	-	2	1	1	2	-	1
CO2	2	1	-	-	-	3	1	-	2	1	2	2	1	-	1
CO3	2	-	-	1	-	3	-	-	1	1	2	2	2	-	1
CO4	1	-	1	-	-	3	-	-	-	2	1	2	2	-	1

COURSE NAME: THERMAL ENGINEERING LAB

COURSE CODE: ME691

CONTACTS: 0: 0: 3

CREDITS: 1.5

Prerequisite: Applied Thermodynamics, Internal Combustion Engine

Course Outcomes:

CO1: Understand the practical operation of 2 stroke and 4 stroke I.C engines using valve timing diagram

CO2: Analyze the performance of multi cylinder engines with the variation of various performances like load and speed.

CO3: Determine the quality of Engine fuels by analyzing its calorific value.

CO4: Analyze the constituents of combustion products for emission characteristics related to public safety.

Course Contents:

Experiment No.	Description
1	Study of cut models of Two stroke and four stroke Petrol and Diesel Engines.
2	Study of valve timing diagram of Petrol & Diesel Engine.
3	Determination of flash point and fire point of sample oil.
4	Determination of calorific value of a fuel by Bomb calorimeter.
5	Performance Test of a Diesel Engine using Mechanical and Electrical dynamometer.
6	Morse Test on multi cylinder petrol engine by electrical break dynamometer.
7	Study of Boiler Cut Models
8	Determination of work input and efficiency of an air compressor

CO – PO/PSO Mapping:

CO	PO 1	PO 2	PO 3	PO 4	PO 5	PO 6	PO 7	PO 8	PO 9	PO 10	PO 11	PO 12	PSO 1	PSO 2	PSO 3
CO1	2	-	2	-	-	-	-	-	2	1	3	2	2	2	-
CO2	2	-	3	2	-	1	-	-	3	1	3	2	2	2	-
CO3	-	-	2	-	-	2	2	-	3	1	3	3	2	2	-
CO4	-	3	2	-	-	2	3	2	3	1	3	3	2	2	-

COURSE NAME: DESIGN LAB

COURSE CODE: ME692

CONTACTS: 0:0:3

CREDITS: 1

Prerequisite: Theory of machines, Dynamics of Machine Theory, Strength of Material, Design of Machine element.

Course Outcomes: After taking this course the students should be able to:

CO1: Identify different mechanical elements and the uses of those elements.

CO2: Analyze existing mechanical elements under static as well as dynamic loading.

CO3: Determine the endurance limit of rotating beam specimen, stress concentration factors by FEA.

CO4: Design a mechanical element by using standards, codes

List of Experiments

1. Study of different mechanical elements e.g Gear, Clutch, Brake, Bearing, Shaft, Spline, Coupling, Keys
2. Determination of Endurance Limit for a rotating beam specimen by using fatigue testing machine.
3. Introduction to CAE, FEA
4. Measurement of stress at a desired point on a deformed body e.g beam under static loading by using strain gauge.
5. Estimation of stress at point on a deformed body e.g beam under static loading by using CAE tool and comparison with the experimental result obtained through Exp. No. 4
6. Determination of Stress concentration factors for different types of discontinuities in mechanical element by FEA using CAE tool.

Course Articulation Matrix:

COs	PO 1	PO 2	PO 3	PO 4	PO 5	PO 6	PO 7	PO 8	PO 9	PO 10	PO 11	PO 12	PSO 1	PSO 2	PSO 3
CO1	-	3	2	1	-	-	-	-	3	2	3	2	1	1	2
CO2	-	1	2	-	-	-	-	-	3	2	3	3	2	1	1
CO3	-	1	3	-	1	-	-	-	2	2	3	2	3	2	2
CO4	-	1	3	-	-	-	-	-	2	2	3	3	3	2	1

COURSE NAME: ROBOTICS LAB

COURSE CODE: EC(ME)691A

CONTACTS: 0: 0: 2

CREDITS:1

Prerequisite: Basic of robotics and electronics

Course Outcomes:

CO1: Describe the configuration of a robotic system from its motion.

CO2: Analyze the control of robotic systems with the help of programs.

CO3: Apply different operation in robot.

CO4: Evaluate different application in industry.

List of Experiments:

Experiment No.	Description
1	Introduction to robot configuration
2	Demonstration of robot with 2 DOF, 3 DOF, 4 DOF
3	Study and selection of Gripper.
4	Programming exercise of robots for Pick and Place activity.
5	Color based pick and place operation using vision system
6	Few case studies of robot applications in industry

CO – PO Mapping:

COs	PO 1	PO 2	PO 3	PO 4	PO 5	PO 6	PO 7	PO 8	PO 9	PO 10	PO 11	PO 12	PSO 1	PSO 2	PSO 3
CO1	3	1	2	-	2	-	-	-	-	2	2	2	1	1	2
CO2	2	-	1	-	1	-	-	1	-	2	2	3	2	1	1
CO3	2	1	3	-	1	1	-	-	-	2	3	2	3	2	2
CO4	2	1	2	-	1	-	-	1	-	2	3	3	3	2	1

COURSE NAME: ELECTRICAL MACHINES LAB

COURSE CODE: EE(ME)691B

CONTACT: 0:0:2

CREDITS: 1

Prerequisite: Electrical Machines Theory

Course Outcome: On completion of the course students will be able to

1. Formulate and then analyze the working of any electrical machine under loaded and unloaded conditions.
2. Analyze the response of DC machine, Three Phase Induction Motor, Synchronous Machine and Fractional kW Motors.
3. Troubleshoot the operation of DC machine, Three Phase Induction Motor, Synchronous Machine and Fractional kW Motors.

Course Content:

At least 8 (eight) of the following experiments to be conducted.

1. Study of the characteristics of a separately excited d.c. generator.
2. Plot the O.C.C. of a d.c. generator & find the critical resistance.
3. Perform load test of d.c. shunt motor to determine efficiency and study the different characteristics of d.c. shunt motor.
4. Perform load test of d.c. series motor to determine efficiency and study the different characteristics of d.c. series motor.
5. Determine the efficiency of a D.C. motor by Swinburn's test.
6. Study different type of starting of 3 phase induction motor & their comparison.
7. Perform No-load test and Blocked-rotor test on 3-phase induction motor & draw the equivalent circuit from the two tests.
8. Study of performance of three phase squirrel-cage Induction motor – determination of Iron-loss, friction & windage loss.
9. Study the effect of capacitor on the starting and running condition of a single-phase induction motor.
10. Perform the load test on 3-phase induction motor and to study the performance characteristics of the motor.
11. Plot V-curve & inverted V-curve of the synchronous motor.

CO-PO/PSO Mapping

CO Code	P1	P2	P3	P4	P5	P6	P7	P8	P9	P10	P11	P12	PS1	PS2	PS3
CO1	2	-	1	1	-	-	-	-	-	1	3	3	-	1	-
CO2	2	2	2	2	-	-	-	-	-	1	2	2	2	-	1
CO3	2	2	1	2	-	-	-	-	-	1	3	2	1	1	2

COURSE NAME: ARTIFICIAL INTELLIGENCE AND MACHINE LEARNING LAB

COURSE CODE: CS(ME)691C

CONTACT: 0:0:2

CREDIT: 1

Prerequisite: Probability, Matrix operations, Basic programming

Course Outcomes: Upon successful completion of this course, students will be able to achieve:

CO1: Learn Advanced Data Analysis skills

CO2: Create AI/ML solutions for various business problems.

CO3: Build and deploy production grade AI/ML applications.

CO4: Apply AI/ML methods, techniques and tools immediate.

Course Contents:

1. Logic programming with Prolog: To specify relationships among objects and properties of objects, problem solving.
2. Introduction to Python Programming: Learn the different libraries - NumPy, Pandas, SciPy, Matplotlib, Scikit Learn.
3. Supervised Learning: Linear Regression predicts a real-valued output based on an input value, Logistic regression- the notion of classification, the cost function for logistic regression, and the application of logistic regression, KNN- classification.
4. Bagging Algorithm: Decision Tree, different ensemble techniques like bagging, boosting, stacking and voting, Random Forest- bagging, Attribute bagging and voting for class selection.
5. Boosting Algorithms: AdaBoost, Stochastic Gradient Boosting, Voting Ensemble.
6. Deployment of Machine Learning Models: simple Web API.

CO-PO/PSO Mapping

CO	PO 1	PO 2	PO 3	PO 4	PO 5	PO 6	PO 7	PO 8	PO 9	PO 10	PO 11	PO 12	PSO 1	PSO 2	PSO 3
CO1	1	-	1	-	-	3	1	-	-	2	1	1	2	-	1
CO2	2	1	-	-	-	3	1	-	2	1	2	2	1	-	1
CO3	2	-	-	1	-	3	-	-	1	1	2	2	2	-	1
CO4	1	-	1	-	-	3	-	-	-	2	1	2	2	-	1

COURSE NAME: SOFT SKILL-II

COURSE CODE: HU(ME)691

CONTACT: 0:0:1

CREDIT: 0.5

Course contents:

1. Communication skills
2. Visual, nonverbal and aural communication
3. Interpersonal communication
4. Developing key traits.
5. Creativity, critical thinking and problem solving

COURSE NAME: INDUSTRIAL TRAINING

COURSE CODE: ME681

CREDIT: 0.5

Course contents:

Collective Data from 3rd to 6th Semester (Summer/Winter Training during Semester Break & Internship should be done after 5th Semester or 6th Semester). All related certificates to be collected by the training/internship coordinator(s).

COURSE NAME: MINOR PROJECT II

COURSE CODE: ME682

CONTACT: 0:0:2

CREDIT: 1

Course contents:

It is intended to start the project work in the semester and carry out both design and fabrication of a mechanical device whose working can be demonstrated. The students in a group of 4 to 6 works on a topic are to be approved by the head of the department under the guidance of a faculty member. The students prepare a comprehensive project report after completing the work to the satisfaction of the supervisor to be submitted at the end of the semester. The project work is evaluated based on oral presentation and the project report may jointly by examiners constituted by the Head of the Department.

4th Year 1st Semester

Sl. No.	Category	Course Code	Course Title	Hours per week				Credits
				L	T	P	Total	
THEORY								
1	Major	ME701	Advanced Manufacturing Technology	3	0	0	3	3
2	Major	ME702	A. Automobile Engineering B. Computer Aided Design C. Turbomachinery	3	0	0	3	3
3	Major	ME703	A. Materials Handling B. Design of Transmission Systems C. Nuclear Power Generation & Supply	3	0	0	3	3
4	Minor	EC(ME)701A	3D Printing and Design	3	1	0	4	4
		EE(ME)701B	Electric Vehicles					
		CS(ME)701C	Cyber Security and Blockchain					
5	Multidisciplinary	HU(CS)701	Economics for Engineers	1	0	0	1	1
PRACTICAL								
1	Major	ME791	Advanced Manufacturing Technology Lab	0	0	2	2	1
2	Major	ME792	A. Automobile Engineering Lab B. Computer Aided Design Lab C. Turbomachinery Lab	0	0	2	2	1
3	Ability Enhancement Course	HU(ME)791	Seminar & Group Discussion	0	0	2	2	1
4	*Internship	ME781	Internship (Min. 1 month)	0	0	0	0	1
5	Project	ME782	Major Project-I	0	0	8	8	4
TOTAL CREDIT								22

*Collective Data from 3rd to 6th Semester (Summer/Winter Training during Semester Break & Internship should be done after 5th Semester or 6th Semester). All related certificates to be collected by the training/internship coordinator(s).

COURSE NAME: ADVANCED MANUFACTURING TECHNOLOGY

COURSE CODE: ME 701

CONTACT: 3:0:0

TOTAL CONTACT HOURS: 36

CREDIT: 3

Prerequisite: Manufacturing Process.

Course Outcomes: On successful completion of the course learners will be able to

CO1: Learn the basics of automation and its application in flexible manufacturing systems.

CO2: Understand the principle of CNC machines and learn their programming language.

CO3: Evaluate the process parameters involved in machining process and analyze their effect on surface finish achieved in various nonconventional processes.

CO4: Get an overview of rapid prototyping and use of 3D printing.

Course Contents

Module No.	Syllabus	Contact Hrs.
1	<p>Introduction to Advanced Manufacturing Technology</p> <p>Manufacturing Systems and Automation: Job shop, Flow lines, Transfer lines, Project shop, Continuous processes, Cellular manufacturing system, Flexible Manufacturing System.</p> <p>Automation:</p> <p>(i) degree of automation and their justified application in different levels of production</p> <p>(ii) benefits and draw backs of employing automation</p> <p>(iii) examples of conventional non-automatic, semi-automatic and automatic machine tools</p> <p>(iv) extent of automation in transfer machines Integrated Manufacturing System: Steps involved in implementation, forming the linked-cell factory, Introduction to Robotics for its implementation in manufacturing</p>	10
2	<p>Basic systems of NC and CNC machines: coordinate system, control –open loop and closed loop, dimensioning – absolute and incremental CNC machine tools ; structure and working principle machining centre (MC) – characteristics and applications. Control of tool – work travel, point – to –point and contouring, interpolation – linear and circular Part programming for NC, CNC and MC systems, Codes used, sequential steps, examples; part programming for machining in CNC lathes, drilling machines and milling, Computer aided part programming, advantages, programming languages, statements in APT,</p>	8

	examples	
3	Non Traditional Manufacturing -Advantages, classification, characteristics Abrasive Jet Machining (AJM): principle, material removal rate Water Jet Machining, Applications, Advantages and limitations. Ultrasonic Machining (USM): Working principle, Influence of Process parameters, Applications. Plasma Arc Machining- principle, applications. Chemical Machining- Blanking, Design factors, advantages and disadvantages. Electro-Chemical Machining, Applications. Electrical Discharge Machining (EDM), Wire-cut EDM: working principle, Dielectric fluid, Advantages & Disadvantages. Electron Beam Machining Principle and Applications. Die sinking. Laser Beam Machining (LBM): Characteristics of Ruby laser, Carbon Dioxide laser, Welding Heat treating, cladding. Hybrid Machining	12
4	Rapid Prototyping- Overview of Rapid Prototyping, Basic Process- CAD Model Creation, Conversion to STL format, Slice the STL File, Layer by layer construction, Clean and finish. Principles, systems, relative advantages and applications of the common RP methods; (i) stereo lithography (SLG) (ii) selective laser sintering (SLS) (iii) fused deposition modeling (FDM) (iv) laminated objects manufacturing (LOM) (v) 3-D Inkjet Printing	6

Text Books:

1. Fundamentals of Modern Manufacturing by Mikeel P. Grover– 3E Wiley
2. Automation, Production systems and CIM – M.P. Groover, Prentice Hall
3. non-conventional machining – P.K. Mishra, Narosa
4. Manufacturing science – Ghosh & Mullick, EWP

References:

5. Rapid prototyping – A. Ghosh, EW Press
6. Non-traditional Manufacturing Processes by Gary F. Benedict– Marcel Dekker
7. Micromachining of Engineering Material by McGeogh, J.A. – Marcel Dekker
8. Advanced Machining Process, Non-traditional and Hybrid Machining Processes by Hassan Abdel- Gawad El- Hofy – McGraw Hill, Mechanical Engineering Science.

CO – PO/PSO Mapping:

CO	PO 1	PO 2	PO 3	PO 4	PO 5	PO 6	PO 7	PO 8	PO 9	PO 10	PO 11	PO 12	PSO 1	PSO 2	PSO 3
CO1	3		2		2		3				1	2	2		
CO2	3	2	2		2		2				2	2		3	
CO3	2	1	1		2		2				1	1			3
CO4	2	2	2		3		2				2	2		2	3

COURSE NAME: AUTOMOBILE ENGINEERING

COURSE CODE: ME 702A

CONTACT: 3:0:0

TOTAL CONTACT HOURS: 36

CREDIT: 3

Prerequisite: Thermodynamics, Kinematics & Theory of Machines.

Course Outcomes: On successful completion of the course learners will be able to

CO1: Understand the basic layout of an automobile.

CO2: Explain the operation of engine cooling, lubrication, ignition, electrical and air conditioning systems.

CO3: Analyze the principles of transmission, suspension, steering and braking systems.

CO4: Study latest developments in automobiles.

Course Contents

Module No.	Syllabus	Contact Hrs.
1	Introduction: History & Development of Automobile. Various sub system of Automobile. Prime Mover: Engine for Two–Wheeler & Three-Wheeled vehicles, Engine for passenger cars, commercial and other vehicle, Fuel system for carbureted engine, MPFI engine and Diesel engine, Lubrication and cooling system.	6
2	Transmission System: Devis steering & Ackerman steering system. Rack & pinion, cam & lever, worm & sector system. Flywheel & clutch. Gearbox sliding and constant mesh type, Automatic Transmission, Universal joint, Propeller shaft. Construction & function of differential, Different types of front & rear axles. Wheel quality, assembly, types of wheels, wheel rims. Construction of tyres and tyre specifications.	12
3	Suspension System Conventional and independent suspension system, application. Automotive Restraints: Seat belt, automatic seat belt tightened system, collapsible steering column and air bags.	6
4	Brake System: Disc & drum brake, Hydraulic brake, Parking brake, Stopping distance.	4
5	Electrical Systems: Battery, generator, Ignition system, Starting system, lighting & signaling.	4
6	Power Requirement: Various resistances such as air resistance, gradient resistance, rolling resistance. Tractive effort. Torque- Speed curve. Horse power calculation.	4

Text Books:

1. Motor Vehicle by Newton, Steed and Garrette 2nd ed, Butter worth.
2. Automobile Mechanics by N.K. Giri, 7th ed, Khanna Publishers.
3. Automobile Mechanics by Heitner Joseph, East West Press.
4. K. Ramakrishna, Automobile Engineering, PHI Learning Pvt. Ltd., New Delhi, 2012.

CO – PO/PSO Mapping:

COs	PO 1	PO 2	PO 3	PO 4	PO 5	PO 6	PO 7	PO 8	PO 9	PO 10	PO 11	PO 12	PSO 1	PSO 2	PSO 3
CO 1	3	1	2	1	2	2	2	1	-	1	1	2	3	-	-
CO 2	2	1	1	-	2	3	2	1	-	1	1	2	-	2	-
CO 3	3	2	2	-	2	2	3	1	-	1	1	2	-	-	2
CO 4	2	1	3	1	2	2	2	1	-	1	2	3	-	2	2

COURSE NAME: COMPUTER AIDED DESIGN

COURSE CODE: ME702B

CONTACT: 3:0:0

TOTAL CONTACT HOURS: 36

CREDIT: 3

Prerequisite: Engineering Drawing, Mathematics

Course Outcome: At the end of the course, the student shall be able to:

CO1. Apply geometric transformations and projection methods in CAD.

CO2. Develop geometric models to represent curves.

CO3. Develop surface models for engineering design.

CO4. Model engineering components using solid modelling techniques for design.

Course Contents

Module No.	Syllabus	Contact Hrs.
Module 1 Introduction	Introduction to CAE, CAD. Role of CAD in Mechanical Engineering, Design process, software tools for CAD, geometric modelling.	3
Module 2 Transformations in Geometric Modeling	Introduction, Translation, Scaling, Reflection, Rotation in 2D and 3D. Homogeneous representation of transformation, Concatenation of transformations. Computer-Aided assembly of rigid bodies, applications of transformations in design and analysis of mechanisms, etc. Implementation of the transformations using computer codes.	5
Module 3 Projections	Projective geometry, transformation matrices for Perspective, Axonometric projections, Orthographic and Oblique projections. Implementation of the projection formulations using computer codes	6
Module 4Introduction to Geometric Modeling for Design	Introduction to CAGD, CAD input devices, CAD output devices, CAD Software, Display Visualization Aids, and Requirements of Modelling	4
Module 5Curves in Geometric Modeling for Design	Differential geometry of curves, Analytic Curves, PC curve, Ferguson's Cubic Curve, Composite Ferguson, Curve Trimming and Blending. Bezier segments Bernstein polynomials, Composite Bezier. B-spline basis functions, Properties of basic functions, NURBS. Conversion of one form of curve to other. Implementation of the all the curve models using computer codes in an interactive manner	7

Module 6 Surfaces in Geometric Modeling for Design	Surfaces entities (planar, surface of revolution, lofted etc.). Free-form surface models (Hermite, Bezier, B-spline surface). Boundary interpolating surfaces (Coon's). Implementation of the all the surface models using computer codes.	6
Module 7 Solids in Geometric Modeling for Design	Solid entities, Boolean operations, Topological aspects, Invariants. Write-frame modeling, B-rep of Solid Modelling, CSG approach of solid modelling. Popular modeling methods in CAD softwares. Data Exchange Formats and CAD Applications:	5

TEXT BOOK:

1. Michael E. Mortenson, Geometric Modelling, Tata McGraw Hill, 2013.
2. A. Saxena and B. Sahay, Computer-Aided Engineering Design, Anamaya Publishers, New Delhi, 2005.
3. Rogers, David F., An introduction to NURBS: with historical perspective, Morgan Kaufmann Publishers, USA, 2001.
4. David F. Rogers, J. A. Adams, Mathematical Elements for Computer Graphics, TMH, 2008.

CO– PO/PSO Mapping:

COs	PO 1	PO 2	PO 3	PO 4	PO 5	PO 6	PO 7	PO 8	PO 9	PO 10	PO 11	PO 12	PSO 1	PSO 2	PSO 3
CO1	3	1	3	1	2	-	2	2	2	1	1	2	1	-	2
CO2	3	2	1	-	2	1	-	1	-	1	1	2	2	-	2
CO3	3	2	3	2	3	2	1	1	-	1	1	2	1	-	2
CO4	3	1	3	2	3	2	1	1	1	1	1	3	2	-	2

COURSE NAME: TURBOMACHINERY

COURSE CODE: ME702C

CONTACT: 3:0:0

TOTAL CONTACT HOURS: 36

CREDIT: 3

Prerequisite: Fluid Mechanics and Fluid machinery

Course Outcomes: Upon successful completion of this course, students will be able to

CO1: Get Basic knowledge about rotary machines, nozzle, diffuser etc.

CO2: Understand about the calculation of efficiency, power etc. of steam turbines and hydraulic turbine.

CO3: Evaluate of efficiency, power required etc. of pumps and compressor

CO4: Design of various incompressible and compressible flow machines.

Course Contents

Module No.	Syllabus	Contact Hrs.
1	Introduction: Classification: Incompressible and compressible flow machines; Radial, axial and mixed flow machines; Turbines vs pumps, fans and compressors. Applications: Water supply, ventilation, power generation, propulsion.	4
2	Incompressible- Flow Machines: Euler Head Equation Hydraulic Turbines: Headrace, penstock, nozzle, runner, draft tube and tail race; Gross head and net head; Velocity diagrams for impulse and reaction turbines; Discharge, head, power and efficiencies. Pumps: Reservoir, foot valve, suction line, pump, delivery line and overhead tank; Static head and losses; Velocity diagrams; Discharge, head, power and efficiencies.	10
3	Compressible-Flow Machines: Static and stagnation states; Isentropic and adiabatic expansion and compression processes; Nozzle, diffuser and rows of stationary and moving blades; Efficiencies.	9
4	Dimensional Analysis: Similarity laws, Volume-flow, mass-flow head and power coefficients, Specific speed and machine selection; Pressure ratio, enthalpy ratio, Reynolds number, Mach number; Surge and choking.	5
5	Testing and Performance Analysis: Measurement devices; affinity laws and unit quantities. Set up and operating characteristics of pumps, turbines; fans and turbo-compressors. Cavitation– cause of cavitation and definition of Thoma's cavitation parameter.	8

Text Books:

1. S.M. Yahya, Turbine, Compressors and Fans.
2. J. Lal, Hydraulic Machines.
3. S.K. Som, G. Biswas and S. Chakraborty, Introduction to Fluid Mechanics & Fluid Machines, TMH.
4. M.M. Das, Fluid Mechanics & Turbo Machines, PHI, 2010.
5. R.K. Bansal, Fluid Mechanics & Machinery, Luxmi Publications.

References:

6. C. Ratnam, A.V. Kothapalli, Fluid Mechanics & Machinery, I.K. International Publishing House Ltd, 2010.
7. C.S.P. Ojha, R. Berndtsson, P.N. Chandramouli, Fluid Mechanics & Machinery, Oxford University Press.
8. Gupta, Fluid Mechanics and Hydraulic Machines, Pearson Publication.
9. A.T. Sayers, Hydraulic and Compressible Flow Turbomachines.
10. R.K. Bansal, Fluid Mechanics and Hydraulic Machines.

CO – PO/PSO Mapping:

CO	PO 1	PO 2	PO 3	PO 4	PO 5	PO 6	PO 7	PO 8	PO 9	PO 10	PO 11	PO 12	PS O 1	PS O 2	PS O 3
CO1	3	-	-	-	-	2	1	-	-	-	1	3	2		
CO2	3	2	-	-	-	-	-	-	1	-	1	3		2	
CO3	3	2	-	-	-	-	-	-	2	-	1	3		1	3
CO4	3	3	3	3	1	2	1	-	1	-	2	3	2		2

COURSE NAME: MATERIALS HANDLING

COURSE CODE: ME703A

CONTACT: 3:0:0

TOTAL CONTACT HOURS: 36

CREDIT: 3

Prerequisite: Manufacturing Technology, Kinematics & Dynamics of Machines.

Course Outcomes:

CO1: Understand the importance of material handling and plant layout.

CO2: Study the design procedures of various material handling equipment & component.

CO3: Analyze the variety of load & selection of material handling system based on application through general analysis procedure.

CO4: Apply the fundamentals of load lifting, automation and auxiliary equipment in material handling with proper design consideration.

Course Contents

Module No.	Syllabus	Contact Hrs.
1	Introduction: Elements of Material Handling System-Importance, Terminology, Objectives and benefits of better Material Handling; Principles and features of Material Handling System; Interrelationships between material handling and plant layout, physical facilities and other organizational functions; Classification of Material Handling Equipment.	4
2	Study of Systems & Material Handling Equipment: Objectives of storage; Bulk material handling; Gravity flow of solids through slides and chutes; Storage in bins and hoppers; Belt conveyors Bucketelevators; Screw conveyors; Vibratory Conveyors; Cabin conveyors; Mobile racks, etc. Auxiliary Equipment: Descriptive specification and use of – (i) Slide and trough gates, (ii) belt, screw and vibratory feeders, (iii) positioners like elevating platform, ramps, universal vice; (v) ball table	10
3	Selection of Material Handling Equipment: Factors affecting for selection; Material Handling Equation; Choice of Material Handling Equipment; General analysis Procedures; Basic Analytical techniques; The unit load concept; Selection of suitable types of systems for applications; Activity cost data and economic analysis for design of components of Material Handling Systems; functions and parameters affecting service; packing and storage of materials	8
4	Hoisting Equipment: Advantage of using steel wire rope	10

	over chain; constructional features of wire ropes; Rope drum design; Pulley system-simple vs. multiple pulley; Load handling attachments: hooks, grabs, tongs, grab bucket; Arrangement of hook suspension with cross piece and pulleys (sheaves); Use and constructional features of (i) hand operated trolley hoist, (ii) winch; (iii) bucket elevator, (iv) Jib crane, (v) overhead traveling crane and (vi) wharf crane; Level luffing system of a wharf crane; Utility of truck mounted and crawler crane. Safety precautions.	
5	Robotic Handling: Materials handling at workplace; Major components of a robot; Applications of robotic handling.	4

Text Books:

1. S. Ray, Introduction to Materials Handling, New Age Int. Pub.
2. T. K. Ray, Mechanical Handling of Materials, Asian Books Pvt. Ltd.
3. T.H. Allegri, Materials Handling: Principles and Practices, CBS Publishers and distributors.
4. J.A. Apple, Material Handling System Design, John Wiley & Sons

CO – PO/PSO Mapping:

COs	PO 1	PO 2	PO 3	PO 4	PO 5	PO 6	PO 7	PO 8	PO 9	PO 10	PO 11	PO 12	PSO 1	PSO 2	PSO 3
CO1	3	1	3	1	1	-	2	2	2	-	1	1	1	-	2
CO2	3	2	1	-	-	1	-	1	-	-	1	2	2	-	1
CO3	3	2	3	2	1	2	1	1	-	-	1	2	1	-	1
CO4	3	1	3	2	1	2	1	1	1	-	1	3	2	-	2

COURSE NAME: DESIGN OF TRANSMISSION SYSTEMS**COURSE CODE: ME703B****CONTACT: 3:0:0****TOTAL CONTACT HOURS: 36****CREDIT: 3****Prerequisite:** Rigid body Mechanics, Strength of Materials, Theory of Machine, Design of machine elements.**Course Outcomes:** On successful completion of the course, the learner will be able to

CO1: Learn the concepts of design to belts, chains and rope drives.

CO2: Understand the concepts of design to spur, helical gears, worm, bevel gears

CO3: Apply the concepts of design to gear boxes

CO4: Design cams, brakes and clutches.

Course Contents

Module No.	Syllabus	Contact Hrs.
1	DESIGN OF FLEXIBLE ELEMENTS Design of Flat belts and pulleys – Selection of V belts and pulleys – Selection of hoisting wire ropes and pulleys – Design of Transmission chains and Sprockets	6
2	SPUR GEARS AND PARALLEL AXIS HELICAL GEARS Speed ratios and number of teeth-Force analysis - Tooth stresses – Dynamic effects – Fatigue strength – Factor of safety – Gear materials – Design of straight tooth spur & helical gears based on strength and wear considerations – Pressure angle in the normal and transverse plane- Equivalent number of teeth-forces for helical gears	8
3	BEVEL, WORM AND CROSS HELICAL GEARS Straight bevel gear: Tooth terminology, tooth forces and stresses, equivalent number of teeth. Estimating the dimensions of pair of straight bevel gears. Worm Gear: Merits and demerits terminology. Thermal capacity, materials-forces and stresses, efficiency, estimating the size of the worm gear pair. Cross helical: Terminology-helix angles-Estimating the size of the pair of cross helical gears.	7
4	GEAR BOXES Geometric progression – Standard step ratio – Ray diagram, kinematics layout -Design of sliding mesh gear box – Design of multi speed gear box for machine tool applications – Constant mesh gear box – Speed reducer unit. – Variable speed gear box, Fluid Couplings, Torque Converters for automotive applications.	7

5	CAMS, CLUTCHES AND BRAKES Cam Design: Types-pressure angle and under cutting base circle determination-forces and surface stresses. Design of plate clutches –axial clutches-cone clutches-internal expanding rim clutches-Electromagnetic clutches. Band and Block brakes – external shoe brakes – Internal expanding shoe brake.	8
---	--	---

Text Books:

1. V. B. Bhandari, Design of Machine Elements, TMH.
2. Shigley, J.E. and Mischke, C.R., Mechanical Engineering Design, Fifth Edition, McGraw-Hill International; 1989.
3. Deutschman, D., Michels, W.J. and Wilson, C.E., Machine Design Theory and Practice, Macmillan, 1992

CO – PO/PSO Mapping:

CO	PO 1	PO 2	PO 3	PO 4	PO 5	PO 6	PO 7	PO 8	PO 9	PO 10	PO 11	PO 12	PSO 1	PSO 2	PSO 3
CO1	1	-	2	-	2	-	-	-	1	1	2	1	2	2	1
CO2	2	3	1	2	-	-	-	-	-	1	3	2	1	3	1
CO3	1	3	3	2	-	-	1	-	-	1	2	2	2	2	2
CO4	2	3	3	3	2	1	-	1	-	1	2	3	1	2	3

COURSE NAME: NUCLEAR POWER GENERATION & SUPPLY

COURSE CODE: ME703C

CONTACT: 3:0:0

TOTAL CONTACT HOURS: 36

CREDIT: 3

Prerequisite: Physics, Chemistry, Heat Transfer, Power plant Engineering.

Course Outcomes:

CO1. Detailed knowledge of nuclear reactor types and associated systems

CO2. Analyze variety of nuclear power plants based on fission and fusion.

CO3. Evaluate the safety assessments and waste management.

CO4. Design and simulate equivalent conditions for practical problem solving.

Course Contents

Module No.	Syllabus	Contact Hrs.
1	Basics of a Nuclear Power Generation, energy from fission and fusion reactions	4
2	Systems in nuclear reactor: Reactor fuel system: Natural and enriched fuels, sources, merits and demerits of different fuels for reactor use, fabrication, handling of fuels and irradiated fuels, fuel management, storage, reprocessing of irradiated fuels. Reactor shutdown systems: Materials for reactor control and choices, liquid vs. solid shut down systems, design aspects Primary heat transport (cooling) system: Heat generation and distribution, Coolant characteristics, Selection of coolants, Coolant Circuit, Core thermal hydraulics, Decay heat removal system. Reactor structure: Core composition, Reflector, Reactor vessel, Safety vessel, Shielding. Thermal, biological, Shield cooling system, Moderator system: Materials, Selection, Design consideration, Circuit, Radioactivity aspects. Cover gas system: Purpose, Selection of material, Design considerations, Circuit. Reactor regulating system: Purpose, Methodology, Design considerations, Actuating mechanism.	10
3	Reactor Design: Principles, Safety classifications, Seismic quality group, Loading considerations under normal operations, design basis accidents such as earthquake, loss of coolant accident (LOCA), blackout, flood, missiles, operator error, Safety features for server accidents, standards, software, verifications etc.	6
4	Nuclear power plants: Types. Thermal reactors: BWR,	8

	PWR, PHWR, GCR, APWR, AHWR etc. Fast reactors Breeders; Fusion power; Off-land NPPs - space power unit, nuclear ships, submarines. Economics of NPPs: Various costs, ROI, Sizing, Operational characteristics.	
5	Radiation protection: Radiation hazard, Exposure pathways, dose unit, measurement, CRP Radioactive Waste Management: Waste categorization, Generation, Handling of wastes.	4
6	Reactor Stages and Safety Assurances: Nuclear safety assurance.	4

Text Books:

1. A.K. Raja, A.P. Srivastava & M. Dwivedi, An Introduction on Nuclear Engineering,
2. Glasstone & Sesons- Nuclear Engineering.
3. P.K. Nag., Nuclear Power Plant, Power Plant Engg. (Steam & Nuclear)
4. Arora & Domkundwar, A course in Power Plant Engg.

CO-PO/PSO Mapping:

COs	PO 1	PO 2	PO 3	PO 4	PO 5	PO 6	PO 7	PO 8	PO 9	PO 10	PO 11	PO 12	PSO 1	PSO 2	PSO 3
CO1	3	2	2	1	-	2	2	-	-	1	1	3	1	-	2
CO2	2	1	1	2	-	2	2	-	-	1	1	2	2	-	1
CO3	2	2	3	1	-	3	3	-	-	1	1	3	1	-	1
CO4	1	1	1	1	2	3	3	-	-	1	1	3	2	-	2

COURSE NAME: 3D PRINTING AND DESIGN

COURSE CODE: EC(ME)701A

CONTACT: 3:1:0

TOTAL CONTACT HOURS: 48

CREDIT: 4

Prerequisite: Computer Aided Design & Drafting, Engineering Materials

Course Outcomes: On successful completion of the course, the learner will be able to

CO1: Develop CAD models for 3D printing and Import and Export CAD data.

CO2: Select a specific material for the given application.

CO3: Select a 3D printing process for an application.

CO4: Apply in product manufacturing using 3D Printing or Additive Manufacturing (AM).

Course Contents

Module No.	Syllabus	Contact Hrs.
1	Introduction: Introduction to 3D Printing, Overview of additive manufacturing techniques, Additive v/s Conventional Manufacturing processes, Applications.	6
2	CAD for Additive Manufacturing: CAD Data formats, Slicing, Data translation, Data loss, STL format	14
3	3D Printing: Process, Equipment, Process parameter, Process Selection for various applications. Application Domains: Aerospace, Electronics, Health Care, Defence, Automotive, Construction, Food Processing, Machine Tools	10
4	Materials: Polymers, Metals, Non-Metals, Process parameter, Process Selection for various applications. Various forms of raw material and their desired properties, Support Materials	6
5	Core issues in 3D Printing: Design and process parameters, Governing Bonding Mechanism, Common faults and troubleshooting	6
6	Post Processing: Requirement and Techniques Support Removal, Sanding, Acetone treatment, polishing, Inspection and testing, Defects and their causes	6

Text Books:

1. Khanna Editorial, —3D Printing and Design, Khanna Publishing House, Delhi.

2. Andreas Gebhardt, —Understanding Additive Manufacturing: Rapid Prototyping, Rapid Tooling, Rapid Manufacturingl, Hanser Publisher, 2011.

3. Amitava Ghosh, Rapid Prototyping, McGraw hill Publishers

CO-PO/PSO Mapping:

COs	PO 1	PO 2	PO 3	PO 4	PO 5	PO 6	PO 7	PO 8	PO 9	PO 10	PO 11	PO 12	PS O 1	PS O 2	PS O 3
CO1	2	2	3	-	3	-	-	-	-	1	2	2	1	-	3
CO2	2	2	3	-	3	-	-	-	-	1	2	3	2	2	2
CO3	2	2	3	-	3	2	2	-	-	1	2	2	2	-	3
CO4	3	2	3	2	3	-	2	-	-	1	2	3	3	-	2

COURSE NAME: ELECTRIC VEHICLES

COURSE CODE: EE(ME)701B

CONTACT: 3:1:0

TOTAL CONTACT HOURS: 48

CREDIT: 4

Prerequisite: Knowledge of digital electronics, knowledge of 8085 microprocessor

Course Outcomes: On successful completion of the course, the learner will be able to:

CO1: Design and develop environment friendly electric Vehicle

CO2: Introduce application of smart grid and electric vehicle for conversion, control and automation

CO3: Understand controlling strategies of electrical vehicles.

CO4: Design and model electric vehicle systems and analyze the energy management strategies.

Course Contents

Module No.	Syllabus	Contact Hrs.
1	Introduction: Electric vehicles (EV) development, past, present, and future, comparison with IC engine drive vehicles. Hybrid Electric Drivetrain, Tractive effort in normal driving, Energy consumption Concept of Hybrid Electric Drive Trains	10
2	Power Converters: Batteries, fuel cells, ultracapacitors. Power converters in EV. Different types of motors used in EV and their torque-speed characteristics, motor control techniques, high performance and efficiency optimized control, sensorless control.	14
3	EV modeling, Tier Characteristics, slip phenomena. Road condition estimation, driving force observer. Sizing the drive system, Design of Hybrid Electric Vehicle and Plug-in Electric Vehicle, Energy Management Strategies, Automotive networking and communication, EV and EV charging standards, V2G, G2V, V2B, V2H.	14
4	EV motion control: model following control, optimum slip ratio control, direct yaw movement control, lateral motion stabilization. Fuel cell Vehicles, Hybrid Electric Vehicles (HEV), series, parallel and seriesparallel (split) systems	10

Text Books:

1. Iqbal Hussein, Electric and Hybrid Vehicles: Design Fundamentals, CRC Press, 2003.
2. Mehrdad Ehsani, Yimi Gao, Sebastian E. Gay, Ali Emadi, Modern Electric, Hybrid Electric and Fuel Cell Vehicles: Fundamentals, Theory and Design, CRC Press, 2004.

3. James Larminie, John Lowry, Electric Vehicle Technology Explained, Wiley, 2003

CO-PO/PSO Mapping:

COs	PO 1	PO 2	PO 3	PO 4	PO 5	PO 6	PO 7	PO 8	PO 9	PO 10	PO 11	PO 12	PSO 1	PSO 2	PSO 3
CO1	3	2	2	-	3	2	3	1	-	-	1	2	2	3	-
CO2	2	1	2	-	3	2	3	1	-	-	1	2	-	-	2
CO3	3	2	2	-	3	2	3	1	-	-	1	2	2	-	2
CO4	2	1	3	-	3	3	3	1	-	-	1	3	-	2	-

COURSE NAME: CYBER SECURITY AND BLOCKCHAIN

COURSE CODE: CS(ME)701C

CONTACT: 3:1:0

TOTAL CONTACT HOURS: 48

CREDIT: 4

Prerequisite: Familiarity in computer Networking, basic concepts about network security.

Course Outcome(s): On successful completion of the course, the learner will be able to

CO1: Understand the importance of professional practice, Law and Ethics in their personal lives and professional careers.

CO2: Acquire in depth knowledge of information technology act, security policies, and legal framework of right to privacy, data security and data protection

CO3: Develop the understanding of relationship between commerce and cyberspace

CO4: Be familiar with network security threats and countermeasures

Course Contents

Module No.	Syllabus	Contact Hrs.
1	Introduction of Cybercrime: Cybercrime, Forgery, Hacking, Software Piracy, Computer Network intrusion Criminals plan attacks, passive attack, Active attacks, cyber stalking.	8
2	Cybercrime Mobile & Wireless devices: Security challenges in mobile devices, cryptographic security for mobile devices, Attacks on mobile/cell phones, Theft, Virus, Hacking, Bluetooth; Different viruses on laptop.	11
3	Tools and Methods used in Cyber-crime: Proxy servers, Password checking, Random checking, Trojan Horses and Backdoors; DOS & DDOS attacks; SQL injection: Buffer over flow Attacks, Scripts Kiddies and Packaged Defense.	10
4	Cybercrime & Cyber security: Phising methods, ID Theft; Online identity method Legal aspects, Indian laws, IT act, Public key certificate, Design of Cyber Security Policy of an Organization, Unicitral Model Law Jurisdiction to prescribe/Legislative Jurisdiction; Jurisdiction to adjudicate to enforce; Cyber Jurisdiction in Civil, Criminal & International Cases.	11
5	Cyber Ethics: The Importance of Cyber Law, Significance of cyber-Ethics, Need for Cyber regulations and Ethics. Ethics in Information society, Introduction to Artificial Intelligence Ethics: Ethical Issues in AI and core Principles, Introduction to Block chain Ethics.	8

Text Books:

1. Cyber security by Nina Gobole & Sunit Belapune; Pub: Wiley India.
2. Chris Reed & John Angel, Computer Law, OUP, New York, (2007).

COURSE NAME: ECONOMICS FOR ENGINEERS

COURSE CODE: HU(CS)701C

CONTACT: 1:0:0

TOTAL CONTACT HOURS: 12

CREDIT: 1

Prerequisite: MATH – College Algebra, Pre-Calculus Algebra and Trigonometry.

Course Outcome(s):

CO1: Apply the appropriate engineering economics analysis method(s) for problem solving: present worth, annual cost, rate-of-return, payback, break-even, benefit-cost ratio.

CO2: Evaluate the cost effectiveness of individual engineering projects using the methods learned and draw inferences for the investment decisions.

CO3: Compare the life cycle cost of multiple projects using the methods learned, and make a quantitative decision between alternate facilities and/or systems.

CO4: Evaluate the profit of a firm, carry out the break even analysis and employ this tool to make production decision.

CO5: Discuss and solve advanced economic engineering analysis problems including taxation and inflation.

Course Contents

Module No.	Syllabus	Contact Hrs.
1	Introduction: Managerial Economics- Objectives and goals Managerial Decisions-Decision Analysis.	1
2	Demand and Supply Analysis: Demand-Types of demand-determinants of demand-Demand function-Demand Elasticity-Demand forecasting-Supply-Determinants of supply-Supply function-Supply Elasticity.	2
3	Cost Analysis: Element of costs, Marginal cost, Marginal Revenue, Sunk cost, Opportunity cost, Break-even analysis – PV ratio.	2
4	Elementary economic Analysis: Inflation-Meaning of inflation, types, causes, measures to control inflation. National Income-Definition, Concepts of national income, Method of measuring national income.	2
5	Financial Accounting: Concepts and Definition of Accounting, Journal, Ledger, Trial Balance. Trading A/C, Profit& Loss A/C and Balance Sheet.	3
6	Investment Decision: Time value of money- Interest - Simple and compound, nominal and effective rate of interest, Evaluation of engineering projects Present worth method, Future worth method, Annual worth method, Internal rate of return method, Cost benefit analysis for public projects.	2

Text books:

1. Riggs, Bedworth and Randhwa, —Engineering Economics, McGraw Hill Education India
2. Principles of Economics, Deviga Vengedasalam; Karunagaran Madhavan, Oxford University Press.

Reference Books:

1. Engineering Economy by William G. Sullivan, Elin M. Wicks, C. Patric Koelling, Pearson
2. R. Paneer Seelvan, — Engineering Economics, PHI.
3. Ahuja, H.L., —Principles of Micro Economics, S.Chand & Company Ltd

CO-PO/PSO MAPPING:

COs	PO 1	PO 2	PO 3	PO 4	PO 5	PO 6	PO 7	PO 8	PO 9	PO 10	PO 11	PO 12	PSO 1	PSO 2	PSO 3
CO1	-	-	-	-	-	-	-	-	-	2	1	1	-	-	1
CO2	-	-	-	3	-	-	-	-	-	-	-	-	-	-	1
CO3	-	-	-	-	-	-	-	-	3	-	-	-	-	-	1
CO4	-	-	-	-	-	-	-	-	-	-	2	2	-	-	1

COURSE NAME: ADVANCED MANUFACTURING TECHNOLOGY LAB

COURSE CODE: ME791

CONTACT: 0:0:3

TOTAL CONTACT HOURS: 36

CREDIT: 1.5

Prerequisite: Advanced Manufacturing

Course Outcomes: After successful completion of the course, the student would be able to

CO1: Program a CNC turning or milling machine for preparing a job.

CO2: Evaluate the process parameters involved in CNC machining

CO3: Analyze the principles of Robot programming and carryout hands-on practice

CO4: Study any nonconventional machining process and 3D printing.

Course Contents

- 1) Programming on CNC Lathe.
- 2) Programming on CNC Milling Machine
- 3) Study of geometry of robot manipulator, actuators and grippers
- 4) Robot Programming.
- 5) Parametric Study of Electric-Discharge Machining
- 6) Study of AJM/USM/ECM

CO-PO/PSO Mapping:

CO	PO 1	PO 2	PO 3	PO 4	PO 5	PO 6	PO 7	PO 8	PO 9	PO 10	PO 11	PO 12	PS O 1	PS O 2	PS O 3
CO1	3	-	2	-	2	-	3	-	-	-	2	2	-	-	3
CO2	3	2	2	-	2	-	2	-	-	-	2	2	3	-	-
CO3	2	1	1	-	2	-	2	-	-	-	3	1	-	-	3
CO4	2	2	2	-	3	-	2	-	-	-	3	2	-	2	-

COURSE NAME: AUTOMOBILE ENGINEERING LAB

COURSE CODE: ME792A

CONTACT: 0:0:3

TOTAL CONTACT HOURS: 36

CREDIT: 1.5

Prerequisite: I.C Engine and Automobile Engineering.

Course Outcomes: On successful completion of the course learners will be able to

CO1: Understand the basic layout of an automobile.

CO2: Explain the operation of engine cooling, lubrication, ignition, electrical and air conditioning systems.

CO3: Analyze the principles of transmission, suspension, steering and braking systems.

CO4: Evaluate latest developments in automobiles.

Course Contents

- 1) Study of an Automobile Chassis
- 2) Study of Differential Mechanism of an Automobile
- 3) Study of Multiple Clutch of an Automobile
- 4) Study of Braking System (Hydraulic / Air Brake)
- 5) Study and Demonstration of different circuit of carburetor
- 6) Checking the spark plug and setting the port and check the ignition in the spark plug
- 7) Calibration of Bourdon's tube Pressure Gauge
- 8) Study the Electrical System of an Automobile
- 9) Study the assembly of Car Engine
- 10) Air Pollution testing of CO₂, CO, HC, and NO_x.

CO-PO/PSO Mapping:

COs	PO 1	PO 2	PO 3	PO 4	PO 5	PO 6	PO 7	PO 8	PO 9	PO 10	PO 11	PO 12	PSO 1	PSO 2	PSO 3
CO1	3	1	2	1	2	2	2	1	-	1	1	2	3	-	-
CO2	2	1	1	-	2	3	2	1	-	1	1	2	-	2	-
CO3	3	2	2	-	2	2	3	1	-	1	1	2	-	-	2
CO4	2	1	3	1	2	2	2	1	-	1	2	3	-	2	2

COURSE NAME: COMPUTER AIDED DESIGN LAB

COURSE CODE: ME792B

CONTACT: 0:0:3

TOTAL CONTACT HOURS: 36

CREDIT: 1.5

Prerequisite: Computer Aided Design

Course Outcome: At the end of the course, the student shall be able to:

CO1. Apply geometric transformations and projection methods in CAD.

CO2. Develop geometric models to represent curves.

CO3. Develop surface models for engineering design.

CO4. Model engineering components using solid modelling techniques for design.

Course Contents

1. Line Drawing or Circle Drawing experiment: Writing and validation of computer program.
2. Geometric Transformation algorithm experiment for translation/rotation/scaling: Writing and validation of computer program.
3. Design of machine component or other system experiment: Writing and validation of computer program.
4. Understanding and use of any 3-D Modeling Software commands.
5. Pro/E/Idea etc. Experiment: Solid modeling of a machine component
6. Writing a small program for FEM for 2 spring system and validation of program or using a FEM Package
7. Root findings or curve fitting experiment: Writing and validation of computer program.
8. Numerical differentiation or numerical integration experiment: Writing and validation of computer program.

CO– PO/PSO Mapping:

COs	PO 1	PO 2	PO 3	PO 4	PO 5	PO 6	PO 7	PO 8	PO 9	PO 10	PO 11	PO 12	PSO 1	PSO 2	PSO 3
CO1	3	1	3	1	2	-	2	2	2	1	1	2	1	-	2
CO2	3	2	1	-	2	1	-	1	-	1	1	2	2	-	2
CO3	3	2	3	2	3	2	1	1	-	1	1	2	1	-	2
CO4	3	1	3	2	3	2	1	1	1	1	1	3	2	-	2

COURSE NAME: TURBOMACHINERY LAB

COURSE CODE: ME792C

CONTACT: 0:0:3

TOTAL CONTACT HOURS: 36

CREDIT: 1.5

Prerequisite: Fluid Machinery

Course Outcomes: Upon successful completion of this course, students will be able to

CO1: Get Basic knowledge about rotary machines, nozzle, diffuser etc.

CO2: Understand about the calculation of efficiency, power etc. of steam turbines and hydraulic turbine.

CO3: Evaluate of efficiency, power required etc. of pumps and compressor

CO4: Design of various incompressible and compressible flow machines.

Course Contents

1. Study of flow through blade cascades.
2. Performance analysis of centrifugal blowers.
3. Performance analysis of micro-axial flow fans used in cooling of Electronics.
4. Performance analysis of pumps.
5. Study of Turbo-prop Engine.

CO-PO/PSO Mapping:

CO	PO 1	PO 2	PO 3	PO 4	PO 5	PO 6	PO 7	PO 8	PO 9	PO 10	PO 11	PO 12	PSO 1	PSO 2	PSO 3
CO1	3	-	-	-	-	2	1	-	-	-	1	3	2		
CO2	3	2	-	-	-	-	-	-	1	-	1	3		2	
CO3	3	2	-	-	-	-	-	-	2	-	1	3		1	3
CO4	3	3	3	3	1	2	1	-	1	-	2	3	2		2

COURSE NAME: SEMINAR & GROUP DISCUSSION

COURSE CODE: HU(ME)791

CONTACT: 0:0:2

TOTAL CONTACT HOURS: 24

CREDIT: 1

Prerequisite: English language

Course Contents:

Forms of Technical Communication: Technical Report: Definition & importance; Thesis/Project writing: structure & importance; synopsis writing: Methods; Technical research Paper writing: Methods & style; Seminar & Conference paper writing; Expert Technical Lecture: Theme clarity; Analysis & Findings; 7 Cs of effective business writing: concreteness, completeness, clarity, conciseness, courtesy, correctness, consideration, C.V./Resume writing; Technical Proposal: Types, Structure & Draft.

Technical Presentation: Strategies & Techniques: Presentation: Forms; interpersonal Communication; Class room presentation; style; method; Individual conferencing: essentials; Public Speaking: method; Techniques: Clarity of substance; emotion; Humour; Modes of Presentation; Overcoming Stage Fear; Audience Analysis & retention of audience interest; Methods of Presentation: Interpersonal; Impersonal; Audience Participation: Quizzes & Interjections.

Technical Communication Skills: Interview skills; Group Discussion: Objective & Method; Seminar/Conferences Presentation skills: Focus; Content; Style; Argumentation skills: Devices: Analysis; Cohesion & Emphasis; Critical thinking; Nuances: Exposition narration & Description; effective business communication competence: Grammatical; Discourse competence: combination of expression & conclusion; Socio-linguistic competence: Strategic competence: Solution of communication problems with verbal and nonverbal means.

COURSE NAME: MAJOR PROJECT-I

COURSE CODE: ME782

CONTACT: 0:0:8

CREDIT: 4

Prerequisite: Science and Engineering knowledge

It is intended to start the project work early in the seventh semester and carry out both design and fabrication of a mechanical device whose working can be demonstrated. The design and formulation of the problem is expected to be completed in the seventh semester and the fabrication and demonstration will be carried out in the eighth semester. The students in a group of 4 to 6 works on a topic are to be approved by the head of the department under the guidance of a faculty member. The students prepare a comprehensive project report after completing the work to the satisfaction of the supervisor to be submitted at the end of the

semester. The progress of the project is evaluated by a committee may be constituted by the Head of the Department. The project work is evaluated based on oral presentation and the project report may jointly by external and internal examiners constituted by the Head of the Department.

4th Year 2nd Semester

Sl. No.	Category	Course Code	Course Title	Hours per week				Credits
				L	T	P	Total	
THEORY								
1	Major	ME801	A. Micro and Nano Manufacturing B. Maintenance Engineering C. Composite Materials	3	0	0	3	3
2	Major	ME802	A. Renewable Energy System B. Industrial Safety C. Nanotechnology	3	0	0	3	3
3	Minor	ECS(ME)801A	Industrial Instrumentation	3	0	0	3	3
		EE(ME)801B	Energy Conservation & Management					
		CS(ME)801C	Data Science and Industry 4.0					
4	Ability Enhancement Course	HU(ME)801	Industrial Management	2	0	0	2	2
PRACTICAL								
1		ME881	Grand Viva	0	0	0	0	1
2	Project	ME882	Major Project-II	0	0	12	12	6
TOTAL CREDIT								18

COURSE NAME: MICRO AND NANO MANUFACTURING

COURSE CODE: ME801A

CONTACT: 3:0:0

TOTAL CONTACT HOURS: 36

CREDIT: 3

Prerequisite: Traditional and Advanced Micromachining Processes

Course Outcome: On successful completion of the course, the learner will be able to

CO1. Understand different techniques for the synthesis and characterization of nanomaterials.

CO2. Design and analyze methods and tools for micro and nano-manufacturing.

CO3. Select micro and nano-manufacturing methods and identify key variables to improve quality of MEMS.

CO4. Choose appropriate industrially viable process, equipment and tools for a specific product.

Course Contents

Module No.	Syllabus	Contact Hrs.
1	Introduction: Importance of Nano-technology, Emergence of Nanotechnology, Bottom-up and Top-down approaches, challenges in Nanotechnology, Scaling Laws/Sizing effects.	4
2	Nano-materials Synthesis and Processing: Methods for creating Nanostructures; Processes for producing ultrafine powders- Mechanical grinding; Wet Chemical Synthesis of nanomaterials- sol-gel process, Liquid solid reactions; Gas Phase synthesis of nano-materials Furnace, Flame assisted ultrasonic spray pyrolysis; Gas Condensation Processing (GPC), Chemical Vapour Condensation (CVC)- Cold Plasma Methods, Laser ablation, Vapour – liquid –solid growth, particle precipitation aided CVD, summary of Gas Condensation Processing (GPC).	10
3	Structural Characterization: X-ray diffraction, Small angle X-ray Scattering, Optical Microscope and their description, Scanning Electron Microscopy (SEM), Scanning Probe Microscopy (SPM), TEM and EDAX analysis, Scanning Tunneling Microscopy (STM), Atomic force Microscopy (AFM).	7
4	Micro fabrication Techniques: Lithography, Thin Film Deposition and Doping, Etching and Substrate Removal, Substrate Bonding, MEMS Fabrication Techniques, Bulk Micromachining, Surface Micromachining, High- Aspect-Ratio Micromachining	7
5	Nanofabrication Techniques: E-Beam and Nano-Imprint Fabrication, Epitaxy and Strain Engineering, Scanned	5

	Probe Techniques, Self-Assembly and Template Manufacturing.	
6	MEMS devices and applications: Pressure sensor, Inertial sensor, Optical MEMS and RFMEMS, Micro-actuators for dual-stage servo systems.	3

TEXT BOOK:

1. Micromanufacturing, V. K. Jain (Ed.), CRC press, 2012.
2. Micromanufacturing & Nanotechnology, N. P. Mahalik, Springer.
3. Microfabrication & Nanomanufacturing, Mark J. Jackson, CRC press.
4. Introduction to Micromachining, V. K. Jain (Ed.), Narosa publisher, 2010.

CO-PO/PSO Mapping:

CO Codes	PO 1	PO 2	PO 3	PO 4	PO 5	PO 6	PO 7	PO 8	PO 9	PO 10	PO 11	PO 12	PSO 1	PSO 2	PSO 3
CO1	-	-	2	-	-	-	-	-	-	1	-	1	2	-	2
CO2	2	-	3	2	-	-	-	-	-	1	-	2	2	2	3
CO3	2	-	3	2	2	-	-	-	-	1	-	2	1	-	2
CO4	3	-	2	2	2	-	-	-	-	1	-	2	2	2	3

COURSE NAME: MAINTENANCE ENGINEERING

COURSE CODE: ME801B

CONTACT: 3:0:0

TOTAL CONTACT HOURS: 36

CREDIT: 3

Prerequisite: Strength of Material, Machine Design, Measurement and Instrumentation

Course Outcomes: On successful completion of the course learners will be able to

CO1: Get basic knowledge about types and procedure of maintenance, instruments and tools.

CO2: Understand organizational and economic structure of maintenance.

CO3: Evaluate of performance of tools associated with maintenance and lubrication.

CO4: Design maintenance tools for various applications like bearings, drives, pumps, piping etc.

Course Contents

Module No.	Syllabus	Contact Hrs.
1	Introduction: Definitions of repair and maintenance; Importance of maintenance; Different maintenance systems- breakdown, preventive, planned; predictive maintenance through condition monitoring; Maintainability, failure pattern, availability of equipment / systems, design for maintainability. Total Productive Maintenance (TPM): definition, objective & methodology; Implementation of TPM; Lean maintenance; Overall equipment effectiveness (OEE)	8
2	Organizational structures for maintenance: Objective; Maintenance functions and activities; Organizational requirements; Types of maintenance organizations, Manpower planning; Engineering stores & inventory management.	4
3	Economic Aspect of Maintenance: Life cycle costing; Maintenance cost & its impact; Maintenance budget; Cost control; Maintenance audit Procedure, tools, planning, reports.	4
4	Function and use of Maintenance Equipment, Instruments & Tools: Facilities like NDT, painting, coating and cladding, Gas cutting and welding, crack detection, vibration monitor, balancing equipment, compressor, basic machine tools, lubricators and lubricants, chain pulley block, Tools like different types of wrenches, torque wrench, pipe wrench, plier, screw driver, dimension measuring instruments, feeler gauge, scraper, fitting shop tools, spirit level, hand grinder & drill, screw jack, etc.	6
5	Lubrication: Purpose & importance; Type of lubricants, Properties of lubricants; Types of lubrication and their	6

	typical applications, lubrication devices, centralized lubrication system; Gasket, packing and seals;	
6	Repair & Maintenance Procedures: Repair of cracks, threads, worn shafts, keyways, bush bearing, damaged gear tooth. Assembly and dismantling of antifriction bearing; Maintenance of bearing, clutches, coupling, brakes, Alignment of shafts, belt and chain drives, gear drives, centrifugal pump, pipe and pipe fittings, electrical wiring, isolators and main switches, small induction motors; Steps for installation of a machine.	8

Text Books:

1. Mishra and Pathak, Maintenance Engineering and Management, PHI
2. Srivastava, Maintenance Engineering and Management, S. Chand & Company Ltd., New Delhi.
3. K. Venkataraman, Maintenance Engineering and Management, PHI

CO-PO/PSO Mapping:

CO	PO 1	PO 2	PO 3	PO 4	PO 5	PO 6	PO 7	PO 8	PO 9	PO 10	PO 11	PO 12	PSO 1	PSO 2	PSO 3
CO1	3	1	1							1	1	2			3
CO2	2	2	1	1					1	1	2	3	2	1	
CO3	1	2	2	1	2				2	1	1	3		2	3
CO4	1	3	3	2	1	2	1		1	1	2	3			3

COURSE NAME: COMPOSITE MATERIALS

COURSE CODE: ME801C

CONTACT: 3:0:0

TOTAL CONTACT HOURS: 36

CREDIT: 3

Prerequisite: Engineering Materials

Course Outcomes:

CO1: Know the structure and basic properties of composite and nano-composite materials.

CO2: Explore and understand the several methods of composite fabrication.

CO3: Predict the characteristics and performance of composite materials.

CO4: Apply varying composite materials in automotive, aerospace and other applications.

Course Contents

Module No.	Syllabus	Contact Hrs.
1	Introduction to composites: Definition and applications of composite materials, Fibers-glass, carbon, ceramic and aramid fibers; Matrices polymer, graphite, ceramic and metal matrices; characteristics of fibers and matrices. Lamina-assumptions, macroscopic viewpoint, generalized Hookes law, reduction of homogeneous orthotropic lamina, isotropic limit case, orthotropic stiffness matrix, commercial material properties, rule of mixtures, transformation matrix, transformed stiffness.	10
2	Characterization of Composites: Basic assumptions of laminated anisotropic plates, symmetric laminates, angle ply laminates, crossply laminates, laminate structural moduli, evaluation of lamina properties, determination of lamina stresses, maximum stress and strain criteria, von Mises Yield criterion for isotropic materials, generalized Hill's criterion for anisotropic materials, Tsai-Hill's criterion for composites, prediction of laminate failure, thermal analysis of composite laminates	10
3	Performance Analysis of Composites: Analysis of laminated plates equilibrium equations of motion, energy formulation, static bending analysis, buckling analysis, free vibrations, natural frequencies	8
4	Fabrication and application of Composites: Manufacturing of composite materials, bag molding, compression molding, pultrusion, filament winding, other manufacturing processes, Industrial Application of Composite Materials	8

Text Books:

1. Composite materials, K.K. Chawala, 2nd ed., (1987) Springer-Verlag, New York.

2. Nanocomposite Science and Technology, P. M. Ajayan, L. S. Schadler, P. V. Braun, (2003), Wiley-VCH Verlag GmbH Co. KGaA, Weinheim.

3. Mechanics and Analysis of Composite Materials, V.V. Vasiliev and E.V. Morozov,(2001), Elsevier Science Ltd, The Boulevard, Kidlington, Oxford OX5Lgb, UK.

4. Ceramic matrix composites, K.K. Chawala, 1st ed., (1993) Chapman & Hall, London

CO-PO/PSO Mapping:

COs	PO 1	PO 2	PO 3	PO 4	PO 5	PO 6	PO 7	PO 8	PO 9	PO 10	PO 11	PO 12	PSO 1	PSO 2	PSO 3
CO1	3	2	2	1	-	-	-	-	-	1	-	-	2	-	2
CO2	2	-	1	2	1	-	-	1	-	1	2	1	2	-	2
CO3	2	2	2	1	1	1	-	-	-	1	1	1	2	-	2
CO4	2	1	2	2	1	1	-	1	-	1	2	3	2	-	2

COURSE NAME: RENEWABLE ENERGY SYSTEM

COURSE CODE: ME802A

CONTACT: 3:0:0

TOTAL CONTACT HOURS: 36

CREDIT: 3

Prerequisite: Thermodynamics, Power Plant Engineering

Course Outcomes: On successful completion of the course, the learner will be able to
CO1. Create awareness among students about renewable sources of energy and application of renewable technologies in different areas of country.
CO2. Understand the working principle of various renewable energy technologies and systems like solar, wind, tidal and geothermal resources.
CO3. Explain the knowledge of Storage technologies from renewable energy sources.
CO4. Recognize the need and application of alternative biofuels in the field of power production.

Course Contents

Module No.	Syllabus	Contact Hrs.
1	Principles of Renewable Energy: The history and future of energy scenario, Sustainable Development and role of renewable energy, Scientific Principles of renewable energy. Review of principles: thermodynamics, fluid dynamics and heat transfer	4
2	Solar radiation: (i) Sun-Earth geometry (ii) Extra-terrestrial Solar Radiation (iii) Measurement and estimation of solar radiation. Photovoltaic Generation: (i) Photon absorption at Silicon p-n junction (ii) Solar Cell (iii) Application and Systems. Designing a solar system and its implementation	8
3	Solar Water Heating: (i) Flat Plate Collectors: Heat Transfer analysis, Testing (ii) Evacuated Tube Collectors. Applications: (i) Air heaters (ii) Water Desalination (iii) Space Cooling (iv) Solar Concentrators (v) Solar ponds. Designing a solar heating system and its implementation.	7
4	Wind Power: Wind Turbine types & Principles, Calculation of Power production from Wind mills, Betz Criteria	4
5	Wave Power & tidal Power: Basic Concepts of Wave Power, Tidal Basins, Determination of energy conversion. Ocean Thermal Energy Conversion.	5
6	Geothermal Energy: Location and Extraction, Petrothermal systems, Geothermal energy based vapor power cycles	4
7	Biomass & Bio fuels: (i) Use of Biomass (ii) Classification & Use of Bio fuels. Energy Storage, Pumped Hydro	4

	Systems	
--	---------	--

Text Books:

1. Renewable Energy – G. Boyle, 2nd edition, OUP, 2010.
2. Renewable Energy Resources- Twidell, J & Weir, T, 2nd edition, Taylor & Francis, 2006.
3. Non-Conventional Energy Resources- B.H. Khan, T M H, 2010.
4. Non-Conventional Energy Sources- G.D. Rai, Khanna Publishers.

CO-PO/PSO Mapping:

CO	PO 1	PO 2	PO 3	PO 4	PO 5	PO 6	PO 7	PO 8	PO 9	PO 10	PO 11	PO 12	PSO 1	PSO 2	PSO 3
CO1	2	2	2	2	-	2	3	-	-	-	-	3	1	1	1
CO2	2	-	2	-	-	2	3	-	-	-	-	2	2	1	1
CO3	2	-	1	-	-	2	3	-	-	-	-	2	1	1	2
CO4	-	-	-	-	-	2	3	-	-	-	-	3	2	1	2

COURSE NAME: INDUSTRIAL SAFETY

COURSE CODE: ME802B

CONTACT: 3:0:0

TOTAL CONTACT HOURS: 36

CREDIT: 3

Prerequisite: Strength of Material, Machine Design, Measurement and Instrumentation

Course Outcomes: Upon successful completion of this course, students will be able to achieve:

CO1. Primary knowledge of industrial and occupational safety and accident prevention

CO2. Understand occupational health and safety rules and regulations.

CO3. Analyze the safety management issues along with accident compensation acts.

CO4. Manage real life problems in the industries related to accident prevention and safety.

Course Contents

Module No.	Syllabus	Contact Hrs.
1	Development of industrial safety, Developments in Occupational Health, Occupational Safety and Health in India	3
2	Accidents and their prevention Theory of accident, Anatomy of an accident, How Accidents are Caused , Cost of Accidents, Principles of Accident Prevention, Techniques of Accident Prevention, Safe Work Environment, Housekeeping, Job Safety Analysis, Investigation of Accidents, Ergonomics, Personal Protective Equipment, Promotion of Health and Safety, Basic Safety Programming	6
3	Fire hazard Types of fire, Fire Hazards, Fire Explosion, fire prevention, Means of Escape in Case of Fire Inspection Safety Supervision Safety, Responsibility Safety Inspection, Fire prevention authorities, Rules Safety Training Safety Appraisal Safety Communication Safety Audit	5
4	Occupational health and safety Occupational Health, Occupational Health Services in Places of Employment, Occupational Physician, Occupational Health in Developing Countries, Occupational Safety, Occupational Safety in Developing Countries, Promoting Occupational Health and Safety, Work Related Diseases, Occupational Health Hazards Recognition of Hazards, Industrial Hygiene, Occupational Diseases, basics of OHSAS 18001	6
5	SAFETY, HEALTH AND ENVIRONMENT (SHE) EDUCATION AND TRAINING, SHE: elements of training cycle, Assessment of needs. Techniques of	8

	training, design and development of training program. Training methods and strategies types of training. Evaluation and review of training programs, Competence building technique (CBT), concept for training, safety as a on-line function. Role of multi-media communication, Applications of computers. Relevance of WTO regarding safety, health and Environment	
6	Health and safety management Basics of Safety management, Role of safety supervisor, planning for safety, Safety Policies, Safety Promotion, Safety Committee, safety education & training, Health and Safety Process, Measuring Safety, Risk Management and Loss Control	4
7	Accident compensation Brief introduction to different acts - The Dangerous Machines (Regulations) Act, 1983, The Employers' Liability Act, 1938 The (Indian), Fatal Accidents Act, 1855 The Public Liability Insurance Act, 1991, The Workmen's Compensation Act, 1923, The Employees' State Insurance Act, 1948, Role of National Safety Council, International labour office	4

Text Books:

1. Safety management Systems, A. Waring, (Chapman & Hall, 1996)
2. Environmental Health & Safety Management – A Guide to Compliance, N.P. Cheremisinoff, M.L. Graffia, (Noyes Publ. 2003)
3. Safety at Work, J. Ridley & J. Channing (5th. Edn.), (Butterworth & Heinemann, 2001)
4. Occupational Health & Hygiene, J. Stranks, (Pitman Publ., 1995)
5. Safety management: Strategy & Practice, R. Pybuss, (Butterworth & Heinemann, 1997)
6. Essentials of Safety management, H.L. Kalia, A. Singh, S. Ravishankar & S.V. Kamat, (Himalaya Publishing House, 2002)
7. Industrial Health & Safety Management, A.M. Sarma, (Himalaya Publishing House, 2002)

CO-PO/PSO Mapping:

CO	PO 1	PO 2	PO 3	PO 4	PO 5	PO 6	PO 7	PO 8	PO 9	PO 10	PO 11	PO 12	PSO 1	PSO 2	PSO 3
CO1	1	-	1	-	-	3	2	-	-	-	1	1	2	-	-
CO2	2	-	-	-	-	3	2	-	-	-	2	2	1	-	1
CO3	2	-	-	-	-	3	2	-	-	-	2	2	2	-	-
CO4	1	-	1	-	-	3	2	-	-	-	1	2	1	-	1

COURSE NAME: NANOTECHNOLOGY

COURSE CODE: ME802C

CONTACT: 3:0:0

TOTAL CONTACT HOURS: 36

CREDIT: 3

Prerequisite: Material science

Course Outcomes: Upon successful completion of this course, students will be able to

CO1: Identify 0D, 1D, 2D and 3D nanomaterials.

CO2: Gain knowledge the optical and mechanical properties

CO3: Interpret the magnetic and electrical properties.

CO4: Illustrate the use of nanomaterials for different applications

Course Contents

Module No.	Syllabus	Contact Hrs.
1	Introduction of nanomaterials and nanotechnologies, influence of nano over micro/macro, Comparison of nanotechnology with micromanufacturing, Features of nanostructures, Background of nanostructures, Techniques of synthesis of nanomaterials, Tools of the nanoscience, Applications of nanomaterials and technologies.	7
2	Bonding and structure of the nanomaterials, Predicting the Type of Bonding in a Substance crystal structure, One dimensional, Two dimensional and Three dimensional nanostructured materials, Metallic nanoparticles, Surfaces of Materials, Nanoparticle Size and Properties	7
3	Mechanical properties of materials, theories relevant to mechanical properties, techniques to study mechanical properties of nanomaterials, adhesion and friction, thermal properties of nanomaterials.	7
4	Electrical properties, Conductivity and Resistivity, Classification of Materials based on Conductivity, magnetic properties, electronic properties of materials, classification of magnetic phenomena.	8
5	Nano thin films, nanocomposites, new application of nanoparticles in manufacturing of bearings, cutting tools, cutting fluids, medical science, soil science, membrane-based application, polymer based application.	7

Text Books:

1. Mick Wilson, Kamali Kannargare, Geoff Smith, —Nano technology: Basic Science and Emerging technologies, Overseas Press, 2005.

2. Charles P. Poole, Frank J. Owens, —Introduction to Nanotechnology, Wiley Interscience, 2008.

3. Mark A. Ratner, Daniel Ratner, —Nanotechnology: A gentle introduction to the next Big Ideal, Prentice Hall P7R:1st Edition, 2002.

CO-PO/PSO Mapping:

CO	PO 1	PO 2	PO 3	PO 4	PO 5	PO 6	PO 7	PO 8	PO 9	PO 10	PO 11	PO 12	PSO 1	PSO 2	PSO 3
CO1	1	2	-	3	1	-	1	2	-	2	-	2	2	-	-
CO2	2	1	2	-	-	1	2	1	1	1	-	2	1	-	1
CO3	2	3	-	2	1	-	3	2	-	2	-	2	2	-	-
CO4	1	-	2	-	-	2	-	2	-	2	-	2	1	-	1

COURSE NAME: INDUSTRIAL INSTRUMENTATION

COURSE CODE: ECS(ME)801A

CONTACT: 3:0:0

TOTAL CONTACT HOURS: 36

CREDIT: 3

Prerequisite: Metrology and control system

Course Outcomes: Upon successful completion of this course, students will be able to

CO1: Obtain knowledge about different instruments used to measure pressure, temperature, flow, level of liquids and data acquisition etc.

CO2: Elucidate the construction and working of various industrial devices used to measure pressure, sound and flow

CO3: Explicate the construction and working of various industrial devices used to measure temperature, level, vibration, viscosity and humidity

CO4: Ability to analyze, formulate and select suitable sensor for the given industrial applications

Course Contents

Module No.	Syllabus	Contact Hrs.
1	DISPLACEMENT - LVDT, capacitive type transducers- Theory, applications. ACCELEROMETER AND VIBROMETER – Seismic instrument for acceleration measurement, velocity measurement, piezoelectric accelerometer, strain gauge accelerometer - theory and applications.	4
2	PRESSURE: Absolute, gauge and vacuum pressures. Elastic transducers: Elastic diaphragm, Corrugated diaphragm, capsule type - relative merits and demerits, pressure ranges. Bourdon type pressure gauge- Theory, construction, installation, Pressure range, materials Electrical Pressure gauges: Strain gauges, Strain gauge half bridge and full bridge configurations, load cells Vacuum gauges: Mcleod gauge, thermal conductivity gauge, Calibration of pressure gauges, dead weight tester	7
3	TEMPERATURE Non- Electrical gauges: Liquid in glass thermometer, pressure thermometer. Electrical gauges- resistance temperature detector- 2, 3 and 4-wire configurations thermocouples and thermopiles, CJC, compensating wires, thermistor- theory, applications, relative merits and demerits, operating range. Non-contact type temperature gauges - total radiation pyrometer, optical pyrometer, temperature measuring problem in flowing fluid. Thermo well.	6
4	FLOW Variable head type flow meters: orifice plate,	8

	<p>Venturi tube, Flow Nozzle Theory, construction, installation, tapping, selection methods. Variable Area flow meter: Theory, construction and installation</p> <p>Positive displacement type flow meters: Nutating disc, reciprocating piston, oval gear and helix Type-Theory, construction and installation</p> <p>Open channel flow measurements: Different shapes of weirs and corresponding flow relations. Electrical type flow meters: Theory, installation details of electromagnetic flow meter, ultrasonic flow meter</p> <p>Guide lines for selection of flow meters, Calibration of flow meters</p>	
5	<p>LEVEL Non-Electrical gauges: Sight glass type, Float type, displacer type, Air purge system-Theory, arrangements, relative merits and demerits</p> <p>Electrical level gauge: Resistive and capacitive types- Theory, arrangement, limitations</p> <p>Nuclear radiation type, ultrasonic type</p> <p>Differential pressure type level measurement: open and closed tanks</p> <p>Boiler drum level measurement.</p>	6
6	<p>DATA Acquisition, Transmission and Recording: Application in open loop and close loop/ feedback control system - Cable transmission of analog voltage and current signals; cable transmission of digital data; Analog voltmeters and potentiometers; digital voltmeters and multimeters; Electromechanical XT and XY recorders; Analog Cathode-ray oscilloscope.</p>	5

Text Books:

1. R K Jain, —Mechanical and Industrial Measurements, Khanna Publishers Co Ltd., New Delhi.
2. S.K.Singh, —Industrial instrumentation, TMH
3. RK Rajput, —Mechanical Measurements and Instrumentation, SK Kataria and Sons, New Delhi.
4. Donald P. Eckman, " Industrial Instrumentation, Wiley

References:

5. E O Doebelin, Measurement Systems- Application and Design, McGraw Hill
6. T G Beckwith and N L Buck, —Mechanical Measurements, Addition Wesley Publishing Company Limited.
7. J P Holman, —Experimental Methods for Engineers, McGraw Hill
8. Alan S Morris, —Measurement and Instrumentation Principles, Butterworth

CO-PO/PSO Mapping:

COs	PO 1	PO 2	PO 3	PO 4	PO 5	PO 6	PO 7	PO 8	PO 9	PO 10	PO 11	PO 12	PSO 1	PSO 2	PSO 3
CO1	1	2	-	2	1	-	2	2	-	2	-	-	2	-	3
CO2	2	1	2	-	-	1	2	1	1	1	-	-	-	3	-
CO3	3	2	-	2	1	-	2	2	-	1	-	-	3	-	-
CO4	3	-	2	-	-	2	-	3	-	2	-	-	-	2	-

COURSE NAME: ENERGY CONSERVATION & MANAGEMENT

COURSE CODE: EE(ME)801B

CONTACT: 3:0:0

TOTAL CONTACT HOURS: 36

CREDIT: 3

Prerequisite: Engineering Thermodynamics, Power Plant Engineering

Course Outcomes: On successful completion of the course, the learner will be able to

CO1: Obtain knowledge about energy conservation policy, regulations and business practices

CO2: Design to improve the thermal efficiency by designing suitable systems for heat recovery and co-generation

CO3: Analyze the energy audit methods learnt to identify the areas deserving tighter control to save energy expenditure

CO4: Evaluate the cost- benefit analysis of various investment alternatives for meeting the energy needs of the organization

Course Contents

Module No.	Syllabus	Contact Hrs.
1	The Energy Resources; Finite & Renewable Sources	4
2	The Need for Energy Conservation- estimation of Finite fuel resource; Hubbert's model for oil reserve	3
3	Waste Heat Recovery; Waste Heat Exchangers; Commercial Waste Heat Recovery Devices- Recuperators, Regenerative Heat Exchangers, Heat Pipes	3
4	Industrial Energy Conservation- Industrial Insulations; Case Studies for HVAC, Air Compressor, Mechanical Handling & Other Systems, Study of energy efficient methods	8
5	Energy Management & Audit: Definition, energy audit, need, types of energy audit. Energy management (audit) approach-understanding energy costs, Bench marking, energy performance, matching energy use to requirement, maximizing system efficiencies, optimizing the input energy requirements, fuel and energy substitution, energy audit instruments and metering	8
6	Energy Economics – Discount Rate, Payback Period, Internal Rate of Return, Net Present Value, Life Cycle Costing -ESCO concept	6
7	Energy and environment, air pollution, climate change: United Nations Framework Convention on Climate Change (UNFCCC), sustainable development, Kyoto Protocol,	4

	Conference of Parties (COP), Clean Development Mechanism (CDM),	
--	---	--

Text Books:

1. Energy Management- Murphy WR, G Mckay- Butterworth Heinmann, 2007
2. Energy Mangement, Audit & Conservation-De Barun, Vrinda Publications, Delhi, 2007
3. Eastop& Croft- Energy Efficiency, Longman, 1990
4. Turner- Energy Management Handbook, 2nd Ed., Fairmont Press, 1993

CO-PO/PSO Mapping:

CO	PO 1	PO 2	PO 3	PO 4	PO 5	PO 6	PO 7	PO 8	PO 9	PO 10	PO 11	PO 12	PSO 1	PSO 2	PSO 3
CO1	3	2	-	2	1		2	3	-	2	1	2	2	2	1
CO2	3	2	2	-		1	2	1	1	1	1	2	1	3	1
CO3	2	3	-	2	1		2	2	1	1	1	2	2	2	2
CO4	3	1	2	-		2		3	-	2	1	2	1	2	3

COURSE NAME: DATA SCIENCE AND INDUSTRY 4.0

COURSE CODE: CS(ME)801C

CONTACT: 3:0:0

TOTAL CONTACT HOURS: 36

CREDIT: 3

Prerequisite: Probability, Matrix operations, Basic programming

Course Outcomes: Upon successful completion of this course, students will be able to achieve:

1. Learn Advanced Data Analysis skills.
2. Create AI/ML solutions for various business problems.
3. Build and deploy production grade AI/ML applications.
4. Apply AI/ML methods, techniques and tools immediate.

Course Contents

Module No.	Syllabus	Contact Hrs.
1	Introduction to Data Science: Concept of Data Science, Traits of Big data, Web Scraping, Analysis vs Reporting	3
2	Introduction to Programming Tools for Data Science: 2.1 Toolkits using Python: Matplotlib, NumPy, Scikit-learn, NLTK 2.2 Visualizing Data: Bar Charts, Line Charts, Scatter plots 2.3 Working with data: Reading Files, Scraping the Web, Using APIs (Example: Using the Twitter APIs), Cleaning and Munging, Manipulating Data, Rescaling, Dimensionality Reduction	5
3	Machine Learning: Overview of Machine learning concepts– Over fitting and train/test splits, Types of Machine learning– Supervised, Unsupervised, Reinforced learning, Introduction to Bayes Theorem, Linear Regression- model assumptions, regularization (lasso, ridge, elastic net), Classification and Regression algorithms- Naïve Bayes, KNearest Neighbors, logistic regression, support vector machines (SVM), decision trees, and random forest, Classification Errors, Analysis of Time Series- Linear Systems Analysis, Nonlinear Dynamics, Rule Induction, Neural Networks- Learning and Generalization, Overview of Deep Learning	12
4	Introduction to Industry 4.0, Definition of Industry 4.0 What is it all about and why do we have to change industrial production Videos from Bosch, Siemens, ABB, Automotive Industry (VW, Audi, Mercedes),	5

	Developments in USA, Europe, China and other countries, Comparison of Industry 4.0 Factory and today's Factory The 10 most important things that will change with Industry 4.0, Difference between conventional automation and Industry 4.0	
5	Basic principles and technologies of a Smart Factory, Internet of Things (IoT) & Industrial Internet of Things (IIoT) & Internet of Services, Big Data, Cyber-Physical Systems, Value chains in manufacturing companies, Customization of products, Digital Twins, Cloud Computing / Cloud Manufacturing, Security issues within Industry 4.0 networks	5
6	The smart workpiece, The intelligent work piece as basic functionality in implementing Industry 4.0, What is an intelligent workpiece? How to make a workpiece intelligent? Work piece tagging, QR codes and RFID, Communication between work piece and environment. Multi-agent systems in production. Applications for smart work pieces (examples of existing or future applications in the field of manufacturing)	6

Text Books

1. J. Grus, Data Science from Scratch: First Principles with Python, O'Reilly Media, 2019.
2. A. Géron, Hands-On Machine Learning with Scikit- Learn and Tensor Flow: Concepts, Tools, and Techniques to Build Intelligent Systems, 1st Edition, O'Reilly Media, 2017.
3. V.K. Jain, Data Sciences and Analytics, Khanna Publishing House, New Delhi, 2019.
4. V.K. Jain, Big Data and Hadoop, Khanna Publishing House, New Delhi, 2017.
5. J. Jose, Machine Learning, Khanna Publishing House, New Delhi, 2020.
6. R. Chopra, Machine Learning, Khanna Publishing House, New Delhi, 2020.
7. Jean-Claude André, Industry 4.0, Wiley-ISTE.

CO-PO/PSO Mapping

CO	PO 1	PO 2	PO 3	PO 4	PO 5	PO 6	PO 7	PO 8	PO 9	PO 10	PO 11	PO 12	PSO 1	PSO 2	PSO 3
CO1	1	-	1	-	-	3	1	-	-	2	1	1	2	-	1
CO2	2	1	-	-	-	3	1	-	2	1	2	2	1	-	1
CO3	2	-	-	1	-	3	-	-	1	1	2	2	2	-	1
CO4	1	-	1	-	-	3	-	-	-	2	1	2	2	-	1

COURSE NAME: INDUSTRIAL MANAGEMENT

COURSE CODE: HU(ME)801

CONTACT: 2:0:0

TOTAL CONTACT HOURS: 24

CREDIT: 2

Prerequisite: NIL

Course outcome: On successful completion of the course learners will be able to

CO1: Recall and identify the relevance of management concepts.

CO2: Apply management techniques for meeting current and future management challenges faced by the organization

CO3: Compare the management theories and models critically to solve real-life problems in an organization.

CO4: Apply principles of management in order to execute the role as a manager in an organization.

Course Contents

Module No.	Syllabus	Contact Hrs.
1	Management Concepts: Definition, roles, functions and importance of Management, Evolution of Management thought-contribution made by Taylor, Fayol, Gilbreth, Elton Mayo, McGregor, Maslow	4
2	Planning and Control: Planning: Nature and importance of planning, - types of planning, Levels of planning - The Planning Process. – MBO, SWOT analysis, McKinsey's 7S Approach. Organizing for decision making: Nature of organizing, span of control, Organizational structure –line and staff authority. Basic control process -control as a feedback system – Feed Forward Control – Requirements for effective control – control	4
3	Group dynamics: Types of groups, characteristics, objectives of Group Dynamics. Leadership: Definition, styles & functions of leadership, qualities for good leadership, Theories of leadership.	4
4	Work Study and work measurement: Definition of work study, Method Study Steps, Tools and Techniques used in the Method Study and Work Measurement Time Study: Aim & Objectives, Use of stopwatch procedure in making Time Study. Performance rating, allowances and its types. Calculation of Standard Time. Work sampling.	4

5	Marketing Management: Functions of Marketing, Product Planning and development, Promotional Strategy.	2
6	Quality management: Quality definition, Statistical quality control, acceptance sampling, Control Charts –Mean chart, range chart, c chart, p chart, np chart, Zero Defects, Quality circles, Kaizen & Six Sigma, ISO - 9000 Implementation steps, Total quality management.	6

Text Books:

1. Essentials of Management, by Harold Koontz & Heinz Weihrich Tata McGraw
2. Production and Operations Management-K. Aswathapa, K. Shridhara Bhat, Himalayan Publishing House

References:

1. Organizational Behavior, Stephen Robbins Pearson Education, New Delhi
2. New era Management, Daft, 11th Edition, Cengage Learning
3. Principles of Marketing, Kotlar Philip and Armstrong Gary, Pearson publication

CO-PO/PSO Mapping:

CO	PO 1	PO 2	PO 3	PO 4	PO 5	PO 6	PO 7	PO 8	PO 9	PO 10	PO 11	PO 12	PSO 1	PSO 2	PSO 3
CO1									3		3		1		
CO2						2		3	3		3	3		3	
CO3									2		3	3		2	
CO4						2			3		3				3

COURSE NAME: GRAND VIVA

COURSE CODE: ME881

CREDIT: 1

Course Contents

The Comprehensive Viva-Voce will be conducted by a Committee consisting of Head of the Department and all Faculty members of the department. The Comprehensive Viva-Voce is intended to assess the student's understanding of the courses he/ she studied during the 4 years B. Tech. programme.

COURSE NAME: MAJOR PROJECT-II

COURSE CODE: ME882

CONTACT: 0:0:12

CREDIT: 6

Course Contents:

It is intended to start the project work early in the seventh semester and carry out both design and fabrication of a mechanical device whose working can be demonstrated. The design and formulation of the problem is expected to be completed in the seventh semester and the fabrication and demonstration will be carried out in the eighth semester. The students in a group of 4 to 6 works on a topic are to be approved by the head of the department under the guidance of a faculty member. The students prepare a comprehensive project report after completing the work to the satisfaction of the supervisor to be submitted at the end of the semester. The progress of the project is evaluated by a committee may be constituted by the Head of the Department. The project work is evaluated based on oral presentation and the project report may jointly by external and internal examiners constituted by the Head of the Department.